

83185

4/2-Directional Control Valve NG 16, self-switching

- > **Port size:**
Subplate mounting or threaded G1/2
- > **Switch proves absolutely reliable, even at extreme oil temperatures**
- > **Pilot-controlled pressure valve, negligible pressure peaks**
- > **Soft-switching, low noise level**
- > **Resistant to contamination**
- > **Oil leakage connection not required**
- > **Complies with the relevant safety regulations**
- > **International approvals**



Technical features

Design:

This hydraulic valve system is for the continuous switching of a cylinder from »in stroke« to »out stroke«. The switching element is a hardened steel piston which moves in a solid cast iron body. For this reason the valves are suitable for the most rugged and demanding operating conditions.

The system relief valve and all other functions necessary to complete the hydraulic circuit are integrated in the single valve body.

Operation:

The operation is effected without solenoids, and therefore without electrical function. No external signal, no external logic is required. The patented flow and pressure principle guarantees that the switching positions are precisely reached.

Mounting:

- Subplate mounted with 'O'-ring seals
- Directly ported G1/2 into valve body

Certificate No. V 487.01/15

Codes and standards:

EN ISO 13849-1:2008 + AC:2009
IEC 61508 Parts 1-2 and 4-7:2010

Intended application:

Safety function:
Move into basic position at every taking back of supply pressure. The valves fulfil the requirements of the applied standards and can be used in applications up to PLd acc. EN ISO 13849-1.

Specific requirements:

The instructions of the associated Installation and Operating Manual shall be considered.

Technical data – Regenerative version

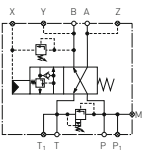
Symbol	Q_{Pump}	$Q_{\text{max. backflow from A>T}}$	Set by factory pressures	Possible pressure settings p_1/p_2 [bar]		Pressure switch setting [bar]		Model
	(l/min.)	(mm)	$p_1/p_2/p_{\text{Diff}}$ [bar]	max. limit	min. limit	for X	for Y	
	10 ... 70	140	220/150/100	315/240	135/100	25	20	8318500.0000.00000

Option selector
83***.0000.*******

Pressure relief valve	Substitute
Pilot operated	1
Pilot operated with solenoid operation	2
Additional function	Substitute
Regenerative version	8
Pressure setting	Substitute
Pressure = 220 bar (3190 psi) Changeover pressure = 150 bar (2175 psi) Differential pressure = 100 bar (1450 psi)	500
Pressure = 200 bar (2900 psi) Changeover pressure = 150 bar (2175 psi) Differential pressure = 100 bar (1450 psi)	555
Pressure = 180 bar (2610 psi) Changeover pressure = 150 bar (2175 psi) Differential pressure = 100 bar (1450 psi)	558
Pressure = 200 bar (2900 psi) Changeover pressure = 150 bar (2175 psi) Differential pressure = 100 bar (1450 psi)	559
Pressure = 220 bar (3190 psi) Changeover pressure = 150 bar (2175 psi) Differential pressure = 100 bar (1450 psi)	562
Pressure = 245 bar (3553 psi) Changeover pressure = 150 bar (2175 psi) Differential pressure = 100 bar (1450 psi)	565
Pressure = 220 bar (3190 psi) Changeover pressure = 150 bar (2175 psi) Differential pressure = 100 bar (1450 psi)	566

Frequency / Voltage	Substitute
24 V d.c. only for electrical vent	02400

General

Type of unit	Directional Control Valve, self switching
Design	Sliding spool valve
Type of mounting	Panel mounting resp. G1/2 cable connection
Weight [kg]	Typ 83185 = 7,8
Mounting position	Optional
Direction of flow	Refer to Symbols
Ambient temperature ϑ [°C]	-20 ... +50°C (-4 ... +122°F)
Size	NG 16
Dimension of unit	Refer to page 4

Electrical characteristics

Voltage	See catalogue number code	
Power consumption	P20 [W] ---	27
Duty cycle	ED_{rel} [%]	100
Protection class	[EN 60529]	IP65
Voltage tolerance	[%]	±10

Hydraulic characteristics

max. Operating pressure		
Connection A, B, P	p [bar]	315
Connection T	p [bar]	120
Pressure *1), factory set	p₁ [bar]	220
Changeover pressure *2), factory set	p₂ [bar]	150, max. 240 permitted
Differential shutdown	p_{Diff} [bar]	100
Fluid	Mineral oil DIN 51524 / 51525 (other on request) HL /HLP biological HEES	
Fluid temperature	ϑ max.	+80°C (+176°F)
Viscosity	ϑ [m²/s]	10 ... 500
Flow		
Q_{max.1} A > T	[l/min]	140
Q_{Pumpe max.}	[l/min]	10 - 70
Filtration	[µm]	25 abs.
Contamination level	ISO 4406 K1a. 20/18/15	

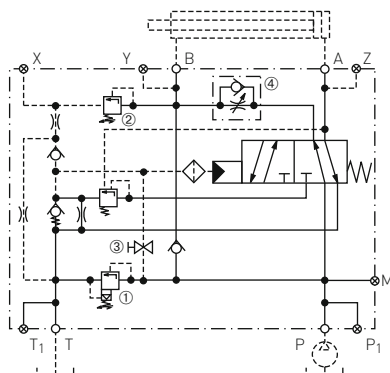
Circuit diagrams and connections
Valve block, regenerative system

*1) Pressure at which the directional valve block switches from the cylinder return stroke to retract stroke.

*2) Pressure at which the directional valve block switches from retract stroke return stroke to the cylinder.

Position ports	Characteristics	Remarks
1	System relief valve	
2	Pressure valve, changeover pressure	Setting at least 35 bar lower than pos.1, max. 240 bar
3	Shut-off valve	If opened, cylinder stops in fully retracted position
P, G1/2	Pump port	
T, G1/2	Tank port	
A, G1/2	Cylinder port	At cylinder head end
B, G1/2	Cylinder port	At cylinder rod end
P1, G1/2	Alternative pump port	Or gauge port, plugged
T1, G1/2	Alternative pump port	
M, G1/4	Measurement connection	Gauge port, plugged
X, G1/4	Pressure switch port (inapplicable if valve is basic version block with throttle check)	Pressure switch, e.g. with break contact. Opens the electrical link, when valve switches over from backward stroke to forward stroke
Y, G1/4	Pressure switch port-B	Pressure switch, e.g. with make contact. Opens the electrical link, when valve switches over from forward stroke to backward stroke
Z, G1/4	Pressure switch port-A	For example, in the case of waste presses, for the 'safety switch' or for the 3/4- or full-signal as required

Functional Description Regenerative version:

In this version of the valve, when the cylinder piston is extending, the oil dispelled on the rod-side is not, as in the basic version, discharged preloaded to the tank via connection B. But rather it flows through a check valve integrated into the valve block to connection P and as such with the pump output flow to the cylinder piston area. This means that there is a significant increase in the feed rate speed of the cylinder piston. This "rapid feed switch" can be overridden with an increase in pressure of 100 bar (set by the manufacturer) caused by external resistance. Then, the pressing operation takes place at a reduced speed and, as in the basic version, the return stroke follows.

Note:

Piston Area: Rod Area must be $\leq m$ 2:1
(e.g. \varnothing 63/45, \varnothing 70/50, \varnothing 80/55, \varnothing 90/65; \varnothing 100/70; \varnothing 110/80; \varnothing 120/85).

Advantages of regenerative circuit:

- Reduction in cycle time by approx. 33%
- More cost-effective than dual-pump mode
- Reduction of pump and filter sizes, of the electric motor capacity and the cable cross sections
- same cylinder piston speeds whether retracting or rapidly extending
- in additional dual-pump mode (switching in specific baseplate) there are extremely short cycle times (3 Feed rate speeds)

Applications:

- This self switching 4/2-way valve block is particularly suitable for driving e.g.
- Waste presses
 - Baling presses
 - Briquette presses
 - Barrel and can presses
 - Conveying systems
 - Compactor trucks with interchangeable containers

Note:

In waste compactors which are driven by the self switching 4/2-way valve, the end positions of the cylinders can be checked without "expensive" and sensitive limit switches. All that is needed are simple pressure switches, connected to ports X or Y.

The cylinder end positions can be used for various different purposes in the control system

- Compactor will remain OPEN at the end of the cycle time
- Compactor will remain CLOSED at the end of the cycle time

Please ask for documents if required.

Dimensions

 Dimensions in mm
 Projection/First angle

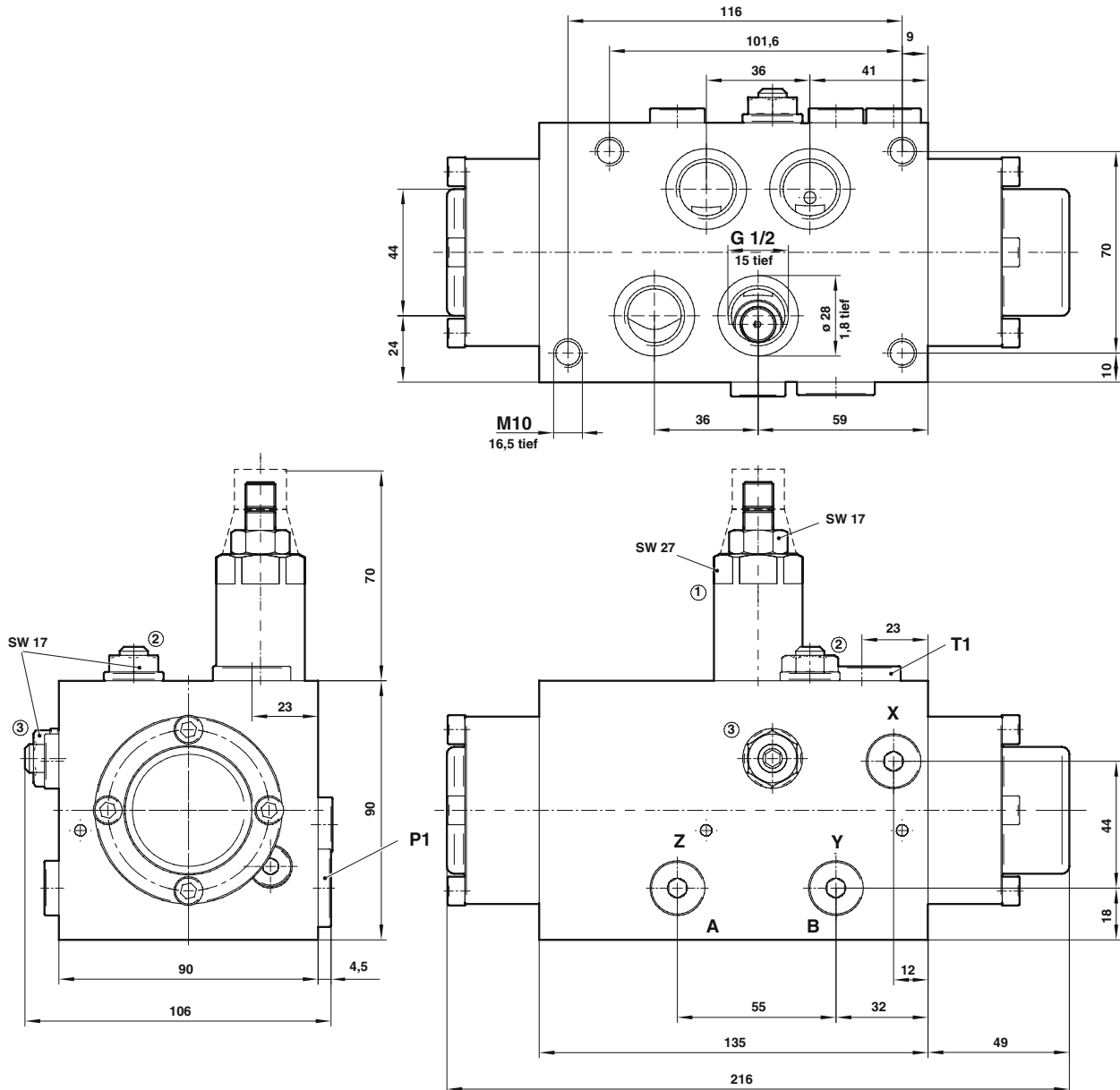
Model:
83185 00...

For subplate mounting 4 'O'-rings 23,47 x 2,62 (PRP-No. 119) are necessary. They are not included with valves without subplates (Part-No. 12 425 56).

Conformity:

The hydraulic 4/2-way valve block is an equipment part without drive system. Thus the hydraulic 4/2-way valve block is excluded from the scope of the Machinery Directive 2006/42/EC.

This indication was reached in accordance with §35 (last paragraph) of "Guideline of the application of the Machinery Directive 2006/42/EC".

According to this indication a declaration of conformity and incorporation as well as CE marking are not required.