



Contents

General Information	Service parts identification	4
	Nameplate	4
	Date code.....	5
	Service bulletins.....	5
	Procedure to identify a part.....	5
Fixed Displacement Motor	Order code	7
	Common parts	8-9
	Special hardware	8-15
	End cap.....	16-17
	Loop flushing	18-19
	Charge pressure.....	20-21
	Shaft	22-23
	Overhaul seal kit	23
Fixed Displacement Cartridge Motor	Order code	25
	Common parts	26-27
	Special hardware	26-29
	End cap.....	30-31
	Loop flushing	32-33
	Charge pressure.....	34-35
	Shaft	36-37
	Overhaul seal kit	37
Variable displacement motor	Order code	39
	Common parts	40-41
	Special hardware	42-45
	Minimum displacement.....	44-45
	End cap.....	46-47
	Loop flushing	46-47
	Charge pressure.....	48-49
	Shaft	48-49
	Control.....	50-51
	Housing.....	52-53
	Servo rate A	52-53
	Servo rate B.....	52-53
	Overhaul seal kit	54



Contents

Variable displacement cartridge motor

Order code 55
 Common parts 56-57
 Special hardware 58-59
 Minimum displacement..... 60-61
 End cap..... 62-63
 Loop flushing..... 62-63
 Charge pressure..... 64-65
 Shaft 64-65
 Control..... 66-67
 Housing..... 68-69
 Servo rate A 68-69
 Servo rate B..... 68-69
 Overhaul seal kit 70

Service bulletin

SB-1988-018 (housing) 71
 SB-1988-023 (piston improvement) 72
 SB-1989-020 (end cap, loop flushing, and adding adjustable cprv) 73-74
 SB-1994-024 (swahplate hold down pin) 75
 SB-1998-007 (end cap) 76-77
 SB-1998-041 (Piston hold down mechanism)..... 78-79
 SB-1998-080 (swashplate)..... 80
 SB-1998-084 (electrical control)..... 81-82
 SB-2000-046 (swashplate bearing pin)..... 83
 SB-2000-047 (loop flushing spring and spring seat) 84
 SB-2001-011 (end cap gasket material)..... 85
 SB-2004-015 (housing) 86
 SB-2005-018 (cylinder block) 87
 SB-2006-012 (shaft seal)..... 88



General information

Service parts identification

The following information and procedure is used to identify the module group, item number, manufacture date, part number, and part name of the parts included in the Series 90, 75 cc fixed displacement cartridge motor.

The parts listed include all parts which may be used when performing either “Minor Repairs”, “Major Repairs” or “Conversions” on the Series 90, 75 cc motor.

Nameplate

Each unit will have a nameplate affixed to the housing. The nameplate will include the following information.

Model Code

The Danfoss model code completely defines the specific unit and must be used when ordering parts to service this product.

Model Number

The Danfoss model number is used by the factory in manufacturing. On repeat orders, a complete unit can be ordered by the model number.

Serial Number

The Danfoss serial number is used to identify the manufacture date and the unit sequence in the build. The serial number is also used to identify the units warranty time period.

The letter code indicates the location of original manufacture (assembly). “C” indicates the unit was originally assembled in China.

The first number (2 digits) indicates the year of manufacture. (“01” would indicate the unit was manufactured in 2001)

The second number (2 digits) indicates the calendar week of manufacture.

The third number (5 digits) is a sequential number used to identify a specific unit.





General information

Date code

The date code is defined as the year and week of manufacture. The same item number may list more than one part number. This indicates that there is more than one configuration for that item number. You will see that there are different date codes for the different part numbers. Find the date code of your unit from the nameplate to determine which service part number you need to order.

EXAMPLE: The service part desired is Item H10

Order Code	Item	Date Begin	Date End	Part Number	Part Name	Usage
N	H10	89-38		8800668	Loop flushing spool, defeated	1
	H10	87-02	89-37	8800021	Loop flushing spool, defeated (SB-1989-020)	1

All units using this order code with a date code of 87-02 and up to and including 89-37, must use part number "8800021". All units with a date code of 89-38 and newer must use part number "8800668".

Service bulletins

A Service Bulletin Number (SB-____-____) may follow the "Part Name" of the part you desire. You must read that Service Bulletin prior to ordering that part. The information contained in these Service Bulletins, as of the print date of this bulletin, are included at the end of this manual. Service Bulletins contain more detailed information such as interchangeability, what additional parts are involved, etc. It is suggested that you add additional Service Bulletins to this manual as you receive them.

Procedure to identify a part

General

The modular design of Series 90 units results in a simplified service parts list and part number identification procedure.

The same item numbers are used for same part names on all units within a product type. (Example: The lip seal - Item L40 has the same item number on all motors.)

A part number that has another number following it in parentheses is done to make this a world wide manual. The first number is sold in Germany. The number in parentheses is sold in the United States. (Example: 140644, customers would order 9005110-5600 if ordering the part in the United States.)

Example of a part identification

The nameplate on a Series 90 motor has an Order Code of 90M075 NC 0 N 8 N 0 C6 W 00 NNN 00 00 20. Use the following procedures to determine the part number of the drive shaft used on this motor.

- 1) Referring to the shaft module in the Order Code (see page 7), the shaft option for this motor is identified by the code "C6". (90M075 NC 0 N 8 N 0 **C6** W 00 NNN 00 00 20.)
- 2) Referring to the Service Parts List, find the shaft group. Next find the order code that relates to this unit, which is "C6". The shaft is found to be item L100 and part number 11012279.





Order code, fixed displacement motor

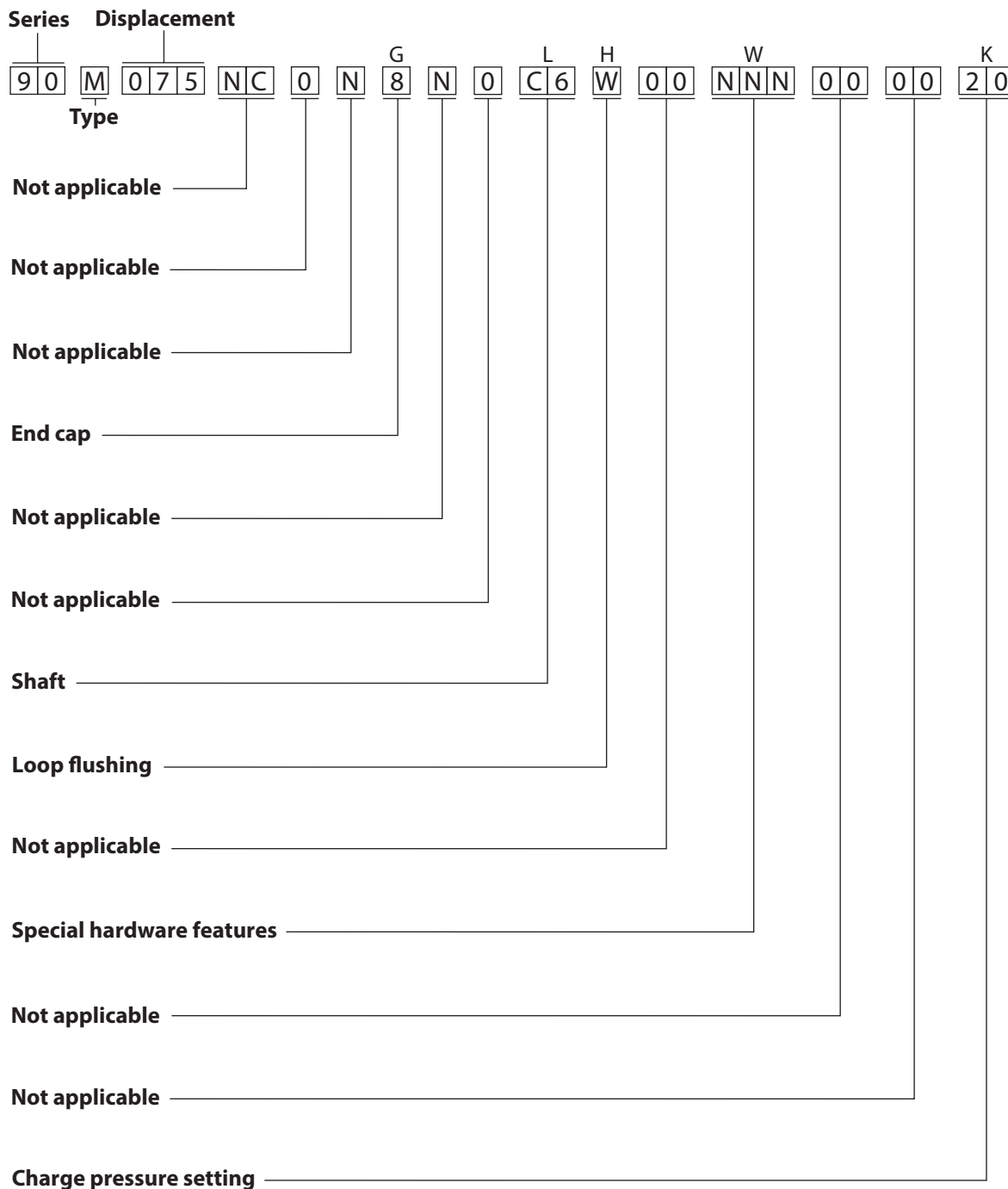

P100 705E



Fixed displacement motor

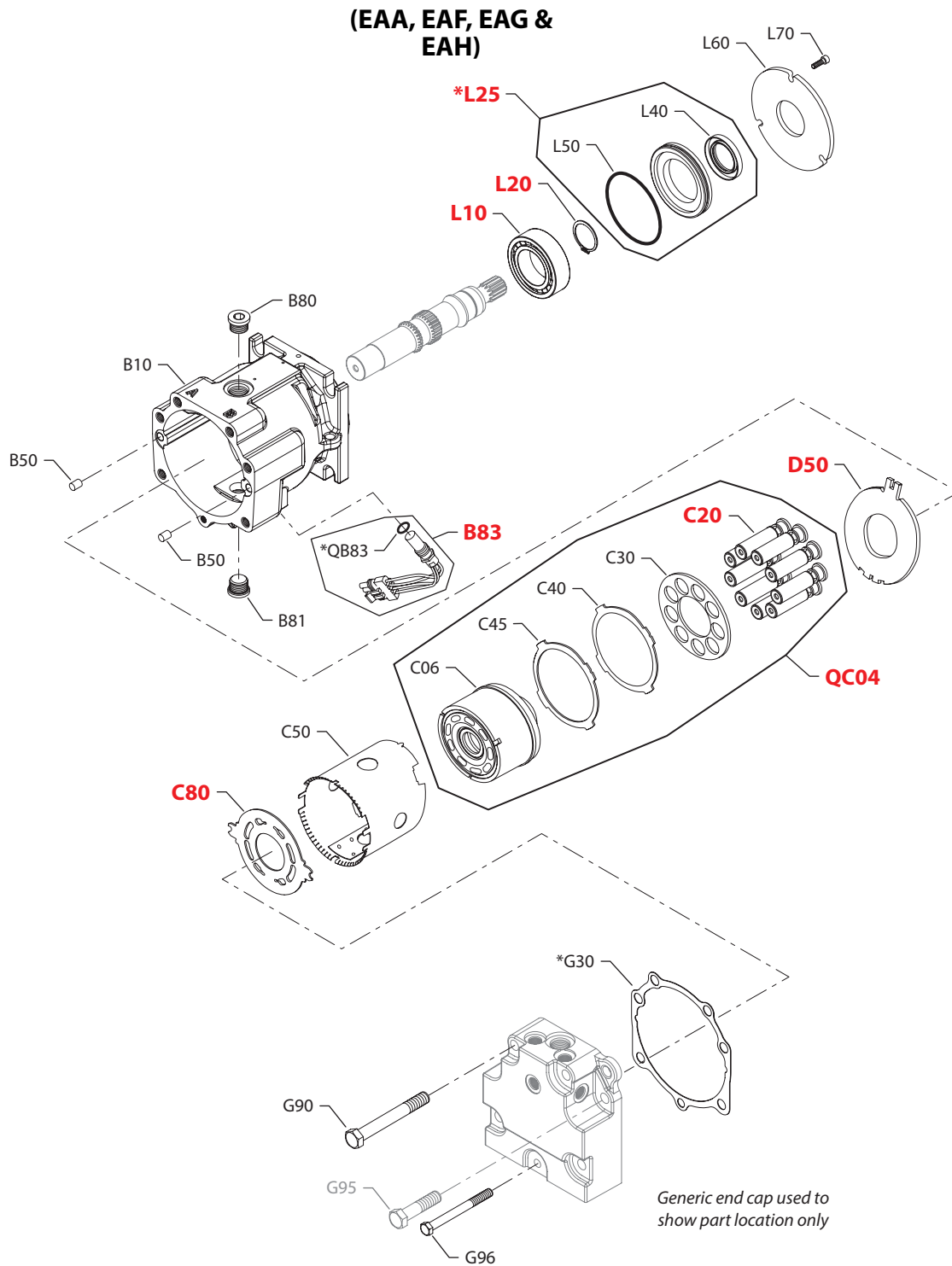

E103 029E

* = included in overhaul seal kit Q210

Enlarged **bold** type item numbers are recommended part to stock for servicing.

Fixed displacement motor
Common parts

Order Code	Item	Date Begin	Date End	Part Number	Part Name	Qty. per Model/Kit
	B10	88-43		8100965	Housing (SB-1988-018 and SB-2004-015)	1
	B50	88-43		9004800-3708	Pin (SB-1988-018)	2
	B80	87-02		664524 (9005110-9000)	Plug assembly	1
	B81	87-02		664524 (9005110-9000)	Plug assembly	1
	C30	87-02		11067350	Slipper guide	1
	C40	87-02		11057797	Slipper guide retainer	1
	C45	87-02		11063828	Slipper guide retainer spacer	1
	C50	87-02		8100475	Hold down tube	1
	C80	87-02		323766	Valve plate	1
	D50	87-02		11136452	Thrust plate	1
	G30	87-02		8100875	End cap gasket (SB-2001-011)	1
	G90	04-51		9007210-1216	Screw (SB-2004-015)	6
	G90	87-02	04-50	9007210-1216	Screw (SB-2004-015)	4
	G95	87-02	04-50	675900 (9007210-1209)	Screw (SB-2004-015)	2
	G96	87-02		9007210-1016	Screw	1
	L10	87-02		5000505	Roller beraing	1
	L20	87-02		9006300-0156	Retaining ring	1
	L25	87-02		519671	Seal assembly (SB-2006-012)	1
	L40	87-02		519666	Lip seal (SB-2006-012)	1
	L50	87-02		684621 (9004104-1530)	O-ring	1
	L60	87-02		516767	Retainer plate	1
	L70	87-02		041160 (9007314-0605)	Screw	3

Special hardware

EAA	B83	87-02		KPPG12508	Speed sensor assembly	1
	C06	87-02		11011714	Cylinder block assy. w/speed ring (SB-2005-018)	1
	C20	87-02		708230	Piston assembly (SB-1988-023)	9
	QB83	87-02		085043 (9004201-3700)	O-ring	1
	QC04	87-02		8510367	Cylinder block kit w/speed ring	1
EAF	B83	87-02		KPPG13808	Speed sensor assembly	1
	C06	87-02		11011714	Cylinder block assy. w/speed ring (SB-2005-018)	1
	C20	87-02		708230	Piston assembly (SB-1988-023)	9
	QB83	87-02		085043 (9004201-3700)	O-ring	1
	QC04	87-02		8510367	Cylinder block kit w/speed ring	1
EAG	B83	87-02		KPPG16511	Speed sensor assembly	1
	C06	87-02		11011714	Cylinder block assy. w/speed ring (SB-2005-018)	1
	C20	87-02		708230	Piston assembly (SB-1988-023)	9
	QB83	87-02		085043 (9004201-3700)	O-ring	1
	QC04	87-02		8510367	Cylinder block kit w/speed ring	1
EAH	B83	06-12		KPPG13808	Speed sensor assembly	1
	C06	06-12		11011714	Cylinder block assembly w/speed ring	1
	C20	06-12		708230	Piston assembly	9
	QB83	06-12		085043 (9004201-3700)	O-ring	1
	QC04	06-12		8510367	Cylinder block kit w/speed ring	1



Fixed displacement motor

**(EAJ, EBA, EBB,
EBF & EFA)**

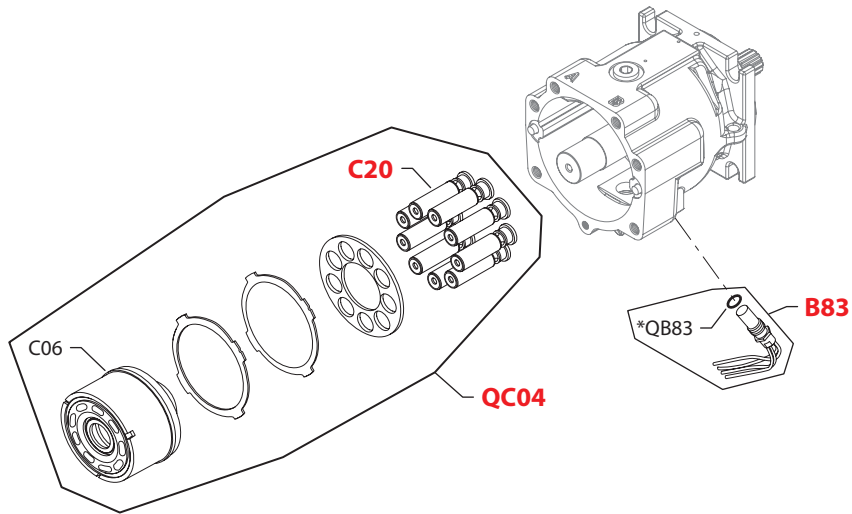

**(EEA, EED, EEH &
EEK)**

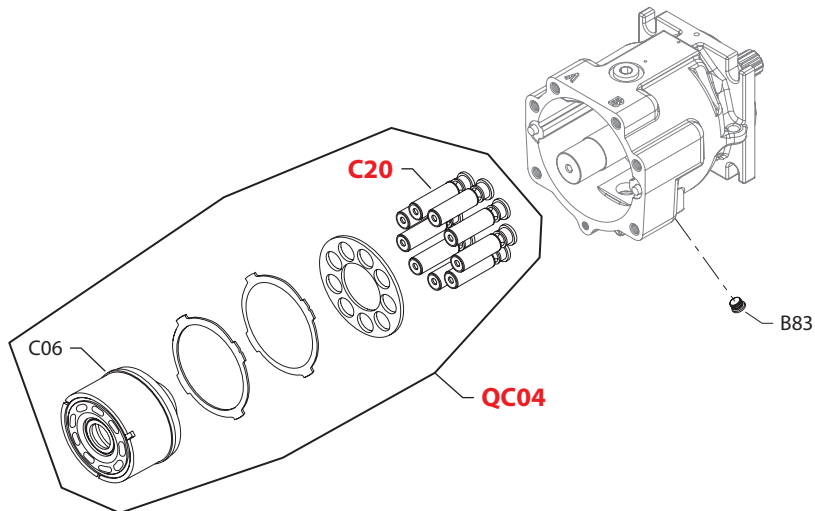

E100 838E

* = included in overhaul seal kit Q210

Enlarged **bold** type item numbers are recommended part to stock for servicing.

Fixed displacement motor
Special hardware

Order Code	Item	Date Begin	Date End	Part Number	Part Name	Qty. per Model/Kit
EAJ	B83	06-48		KPPG166	Speed sensor assembly	1
	C06	06-48		11011714	Cylinder block assembly w/speed ring	1
	C20	06-48		708230	Piston assembly	9
	QB83	06-48		085043 (9004201-3700)	O-ring	1
	QC04	06-48		8510367	Cylinder block kit w/speed ring	1
EBA	B83	87-02		KPPG13408	Speed sensor assembly	1
	C06	87-02		11011714	Cylinder block assembly w/speed ring (SB-2005-018)	1
	C20	87-02		708230	Piston assembly	9
	QB83	87-02		085043 (9004201-3700)	O-ring	1
	QC04	87-02		8510367	Cylinder block kit w/speed ring	1
EBB	B83	87-02		KPPG14408	Speed sensor assembly	1
	C06	87-02		11011714	Cylinder block assembly w/speed ring (SB-2005-018)	1
	C20	87-02		708230	Piston assembly	9
	QB83	87-02		085043 (9004201-3700)	O-ring	1
	QC04	87-02		8510367	Cylinder block kit w/speed ring	1
EBF	B83	15-37		KPPG1A408	Speed sensor assembly	1
	C06	15-37		11011714	Cylinder block assembly w/speed ring (SB-2005-018)	1
	C20	15-37		708230	Piston assembly	9
	QB83	15-37		085043 (9004201-3700)	O-ring	1
	QC04	15-37		8510367	Cylinder block kit w/speed ring	1
EEA	B83	87-02		140644	Plug assembly	1
	C06	87-02		11011714	Cylinder block assembly w/speed ring (SB-2005-018)	1
	C20	87-02		708230	Piston assembly	9
	QC04	87-02		8510367	Cylinder block kit w/speed ring	1
EED	B83	87-02		140644	Plug assembly	1
	C06	87-02		11011714	Cylinder block assembly w/speed ring (SB-2005-018)	1
	C20	87-02		708230	Piston assembly	9
	QC04	87-02		8510367	Cylinder block kit w/speed ring	1
EEH	B83	87-02		140644	Plug assembly	1
	C06	87-02		11011714	Cylinder block assembly w/speed ring (SB-2005-018)	1
	C20	87-02		708230	Piston assembly	9
	QC04	87-02		8510367	Cylinder block kit w/speed ring	1
EEK	B83	87-02		140644	Plug assembly	1
	C06	87-02		11011714	Cylinder block assembly w/speed ring (SB-2005-018)	1
	C20	87-02		708230	Piston assembly	9
	QC04	87-02		8510367	Cylinder block kit w/speed ring	1
EFA	B83	87-02		KPPG136	Speed sensor assembly	1
	C06	87-02		11011714	Cylinder block assembly w/speed ring (SB-2005-018)	1
	C20	87-02		708230	Piston assembly	9
	QB83	87-02		085043 (9004201-3700)	O-ring	1
	QC04	87-02		8510367	Cylinder block kit w/speed ring	1



Fixed displacement motor

(EFM, EFT, EGH,
EGM & EHD)

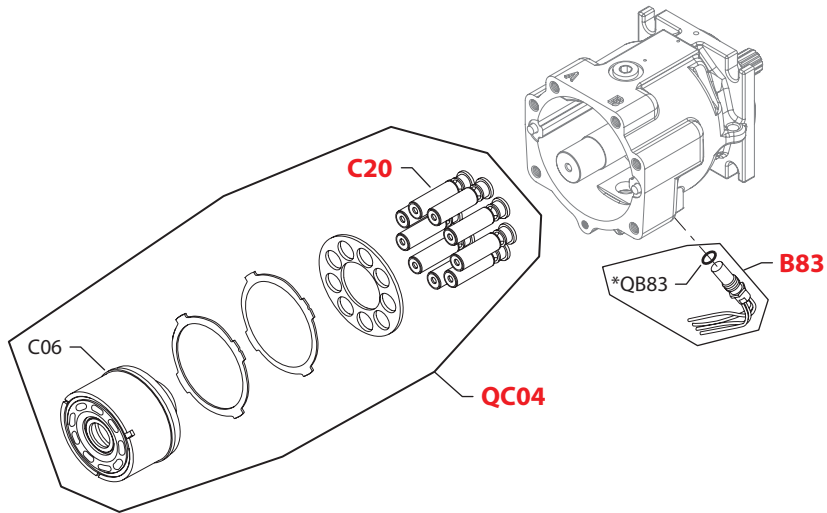

(GCJ, GTA, JAB,
JAB & JAF)

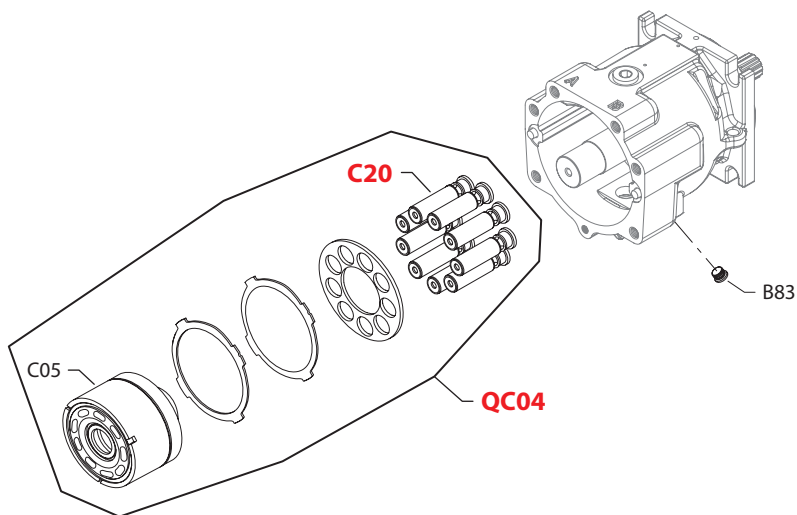

E103 030E

* = included in overhaul seal kit Q210

Enlarged **bold** type item numbers are recommended part to stock for servicing.

Fixed displacement motor
Special hardware

Order Code	Item	Date Begin	Date End	Part Number	Part Name	Qty. per Model/Kit
EFM	B83	13-19		KPPG12730A	Speed sensor assembly	1
	C06	13-19		11011714	Cylinder block assembly w/speed ring	1
	C20	13-19		708230	Piston assembly	9
	QB83	13-19		085043 (9004201-3700)	O-ring	1
	QC04	13-19		8510367	Cylinder block kit w/speed ring	1
EFT	B83	09-50		KPPG16708	Speed sensor assembly	1
	C06	09-50		11011714	Cylinder block assembly w/speed ring	1
	C20	09-50		708230	Piston assembly	9
	QB83	09-50		085043 (9004201-3700)	O-ring	1
	QC04	09-50		8510367	Cylinder block kit w/speed ring	1
EGH	B83	87-02		KPPG13703	Speed sensor assembly	1
	C06	87-02		11011714	Cylinder block assembly w/speed ring (SB-2005-018)	1
	C20	87-02		708230	Piston assembly	9
	QB83	87-02		085043 (9004201-3700)	O-ring	1
	QC04	87-02		8510367	Cylinder block kit w/speed ring	1
EGM	B83	14-22		11150658	Speed sensor assembly	1
	C06	14-22		11011714	Cylinder block assembly w/speed ring (SB-2005-018)	1
	C20	14-22		708230	Piston assembly	9
	QB83	14-22		085043 (9004201-3700)	O-ring	1
	QC04	14-22		8510367	Cylinder block kit w/speed ring	1
EHD	B83	87-02		KPPG16408	Speed sensor assembly	1
	C06	87-02		11011714	Cylinder block assembly w/speed ring (SB-2005-018)	1
	C20	87-02		708230	Piston assembly	9
	QB83	87-02		085043 (9004201-3700)	O-ring	1
	QC04	87-02		8510367	Cylinder block kit w/speed ring	1
GCJ	B83	14-19		140644	Plug assembly	1
	C05	14-19		11025822	Cylinder block assembly	1
	C20	14-19		708230	Piston assembly	9
	QC04	14-19		8510364	Cylinder block kit	1
GTA	B83	14-26		140644	Plug assembly	1
	C05	14-26		11025822	Cylinder block assembly	1
	C20	14-26		708230	Piston assembly	9
	QC04	14-26		8510364	Cylinder block kit	1
JAB	B83	09-50		140644	Plug assembly	1
	C05	09-50		11025822	Cylinder block assembly	1
	C20	09-50		708230	Piston assembly	9
	QC04	09-50		8510364	Cylinder block kit	1
JAF	B83	09-50		140644	Plug assembly	1
	C05	09-50		11025822	Cylinder block assembly	1
	C20	09-50		708230	Piston assembly	9
	QC04	09-50		8510364	Cylinder block kit	1



Fixed displacement motor

(EFT, EGH & EHD)

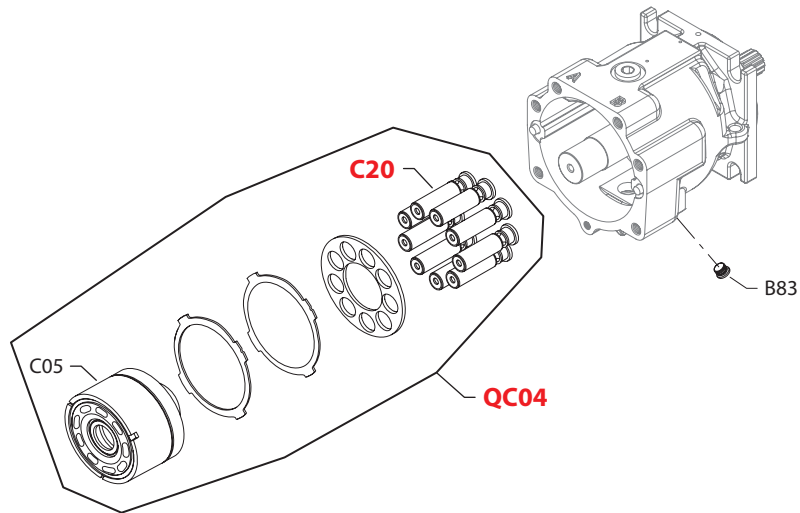

(JAB, JAF, JAG,
JAH, JAK & JCB)

E103 031E

* = included in overhaul seal kit Q210

Enlarged **bold** type item numbers are recommended part to stock for servicing.

Fixed displacement motor
Special hardware

Order Code	Item	Date Begin	Date End	Part Number	Part Name	Qty. per Model/Kit
JAG	B83	09-50		140644	Plug assembly	1
	C05	09-50		11025822	Cylinder block assembly	1
	C20	09-50		708230	Piston assembly	9
	QC04	09-50		8510364	Cylinder block kit	1
JAH	B83	09-50		140644	Plug assembly	1
	C05	09-50		11025822	Cylinder block assembly	1
	C20	09-50		708230	Piston assembly	9
	QC04	09-50		8510364	Cylinder block kit	1
JAK	B83	12-27		140644	Plug assembly	1
	C05	12-27		11025822	Cylinder block assembly	1
	C20	12-27		708230	Piston assembly	9
	QC04	12-27		8510364	Cylinder block kit	1
JCB	B83	12-27		140644	Plug assembly	1
	C05	12-27		11025822	Cylinder block assembly	1
	C20	12-27		708230	Piston assembly	9
	QC04	12-27		8510364	Cylinder block kit	1
MAA	B83	09-50		140644	Plug assembly	1
	C05	09-50		11025822	Cylinder block assembly	1
	C20	09-50		708230	Piston assembly	9
	QC04	09-50		8510364	Cylinder block kit w/speed ring	1
MBX	B83	15-22		140644	Plug assembly	1
	C05	15-22		11128847	Cylinder block assembly	1
	C20	15-22		11153140	Piston assembly	9
	QC04	15-22		11153144	Cylinder block kit w/speed ring	1
MIX	B83	09-50		140644	Plug assembly	1
	C05	09-50		11128847	Cylinder block assembly	1
	C20	09-50		11153140	Piston assembly	9
	QC04	09-50		11153144	Cylinder block kit w/speed ring	1
NNM	B83	13-31		140644	Plug assembly	1
	C05	13-31		11025822	Cylinder block assembly (SB-2005-018)	1
	C20	13-31		708230	Piston assembly	9
	QC04	13-31		8510364	Cylinder block kit w/speed ring	1
NNN	B83	87-02		140644	Plug assembly	1
	C05	87-02		11025822	Cylinder block assembly (SB-2005-018)	1
	C20	87-02		708230	Piston assembly	9
	QC04	87-02		8510364	Cylinder block kit w/speed ring	1



Fixed displacement motor

(1, 8, D & L)

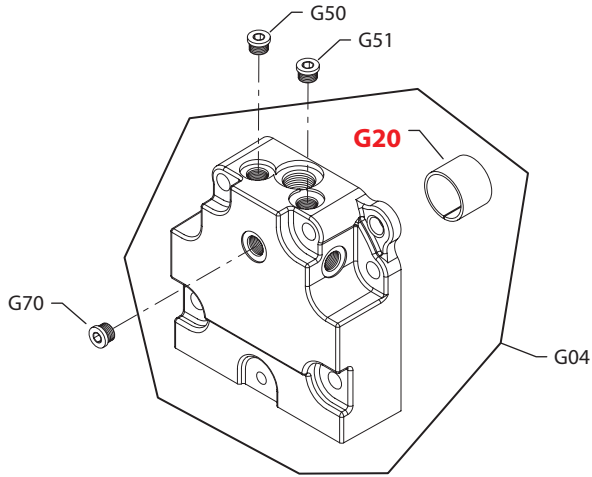

(3 & 7)

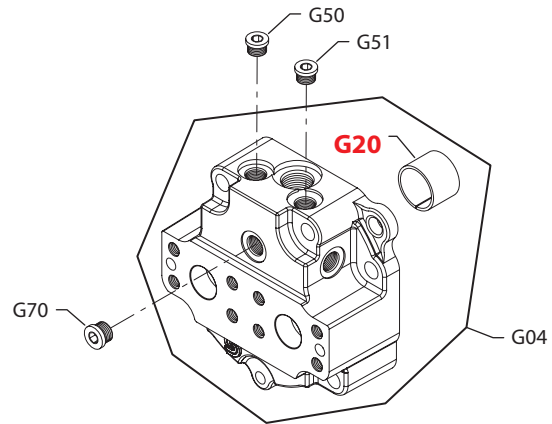

(G)

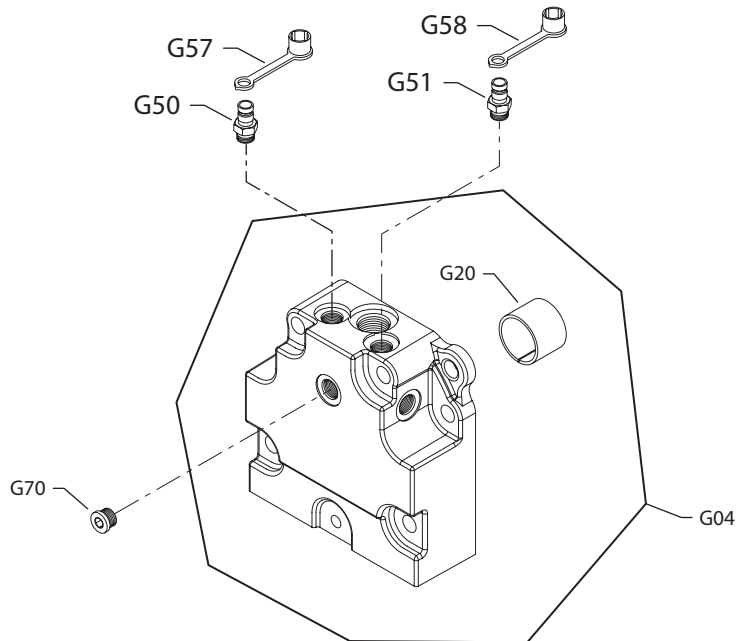

E100 821E

* = included in overhaul seal kit Q210

Enlarged **bold** type item numbers are recommended part to stock for servicing.

Fixed displacement motor
End cap

Order Code	Item	Date Begin	Date End	Part Number	Part Name	Qty. per Model/Kit
1	G04	98-34		8100967 (8100733)	End cap assy., twin ports (SB-1989-020 & 1998-007)	1
	G20	87-02		11017393 (8700013)	Journal bearing	1
	G50	87-02		140644	Plug assembly	1
	G51	87-02		140644	Plug assembly	1
	G70	87-02		140644	Plug assembly	1
3	G04	98-34		8100968 (8100734)	End cap assy., axial ports (SB-1989-020 & 1998-007)	1
	G20	87-02		11017393 (8700013)	Journal bearing	1
	G50	87-02		140644	Plug assembly	1
	G51	87-02		140644	Plug assembly	1
	G70	87-02		140644	Plug assembly	1
7	G04	98-34		8100968 (8100734)	End cap assy., axial ports (SB-1989-020 & 1998-007)	1
	G20	87-02		11017393 (8700013)	Journal bearing	1
	G50	87-02		140644	Plug assembly	1
	G51	87-02		140644	Plug assembly	1
	G70	87-02		140644	Plug assembly	1
8	G04	98-34		8100967 (8100733)	End cap assy., twin ports (SB-1989-020 & 1998-007)	1
	G20	87-02		11017393 (8700013)	Journal bearing	1
	G50	87-02		140644	Plug assembly	1
	G51	87-02		140644	Plug assembly	1
	G70	87-02		140644	Plug assembly	1
D	G04	98-34		8100966 (8100731)	End cap assembly, twin metric ports (SB-1998-007)	1
	G20	95-40		11017393 (8700013)	Journal bearing	1
	G50	87-02		140644	Plug assembly	1
	G51	87-02		140644	Plug assembly	1
	G70	87-02		140644	Plug assembly	1
G	G04	96-44		8100966 (8100731)	End cap assembly, twin metric ports	1
	G20	96-44		11017393 (8700013)	Journal bearing	1
	G50	96-44		8700127	Diagnostic receptical assembly	1
	G51	96-44		8700127	Diagnostic receptical assembly	1
	G57	96-44		8700128	Dust cover	1
	G58	96-44		8700128	Dust cover	1
	G70	96-44		140644	Plug assembly	1
L	G04	96-35		11006962	End cap assembly, twin ports	1
	G20	96-35		11017393 (8700013)	Journal bearing	1
	G50	96-35		140644	Plug assembly	1
	G51	96-35		140644	Plug assembly	1
	G70	96-35		140644	Plug assembly	1



Fixed displacement motor

(N)

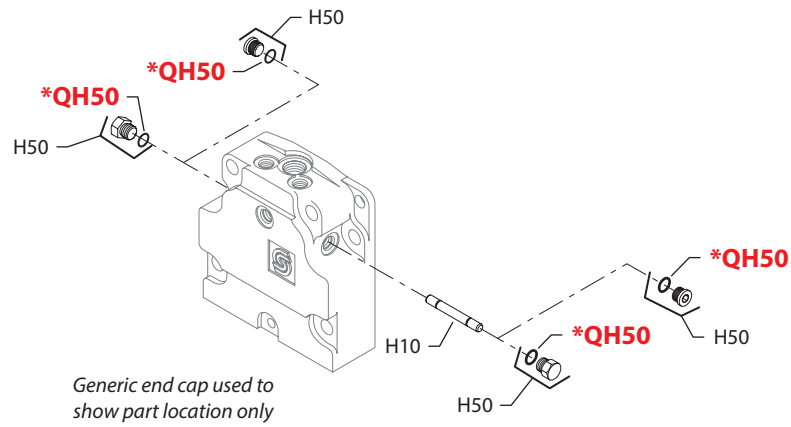

(W)

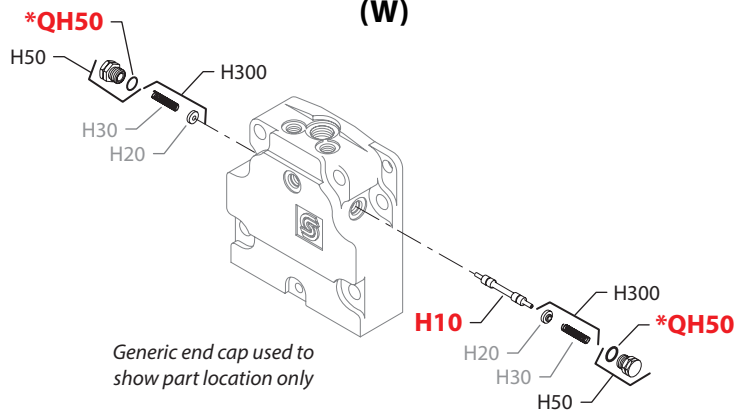

* = included in overhaul seal kit Q210

E100 773E

Enlarged **bold** type item numbers are recommended part to stock for servicing.

Fixed displacement motor
Loop flushing

Order Code	Item	Date Begin	Date End	Part Number	Part Name	Qty. per Model/Kit
N	H10	89-38		8800668	Loop flushing spool, defeated	1
	H10	87-02	89-37	8800021	Loop flushing spool, defeated (SB-1989-020)	1
	H50	87-02		140644	Plug assembly	2
	QH50	87-02		085043 (9004201-3700)	O-ring	2
W	H10	89-38		1118733	Shuttle spool	1
	H10	89-38	89-37	674473 (8800069)	Loop flushing spool, defeated (SB-1989-020)	1
	H20	87-02	89-37	8800265	Spring guide (SB-1989-020)	2
	H30	87-02	89-37	8800067	Spring (SB-1989-020)	2
	H50	89-38		518016	Plug assembly	2
	H50	87-02	89-37	9005475-0069	Plug assembly (SB-1989-020)	2
	H300	89-38		513596	Spring guide assembly (SB-2000-047)	2
	QH50	87-02		085043 (9004201-3700)	O-ring	2



Fixed displacement motor

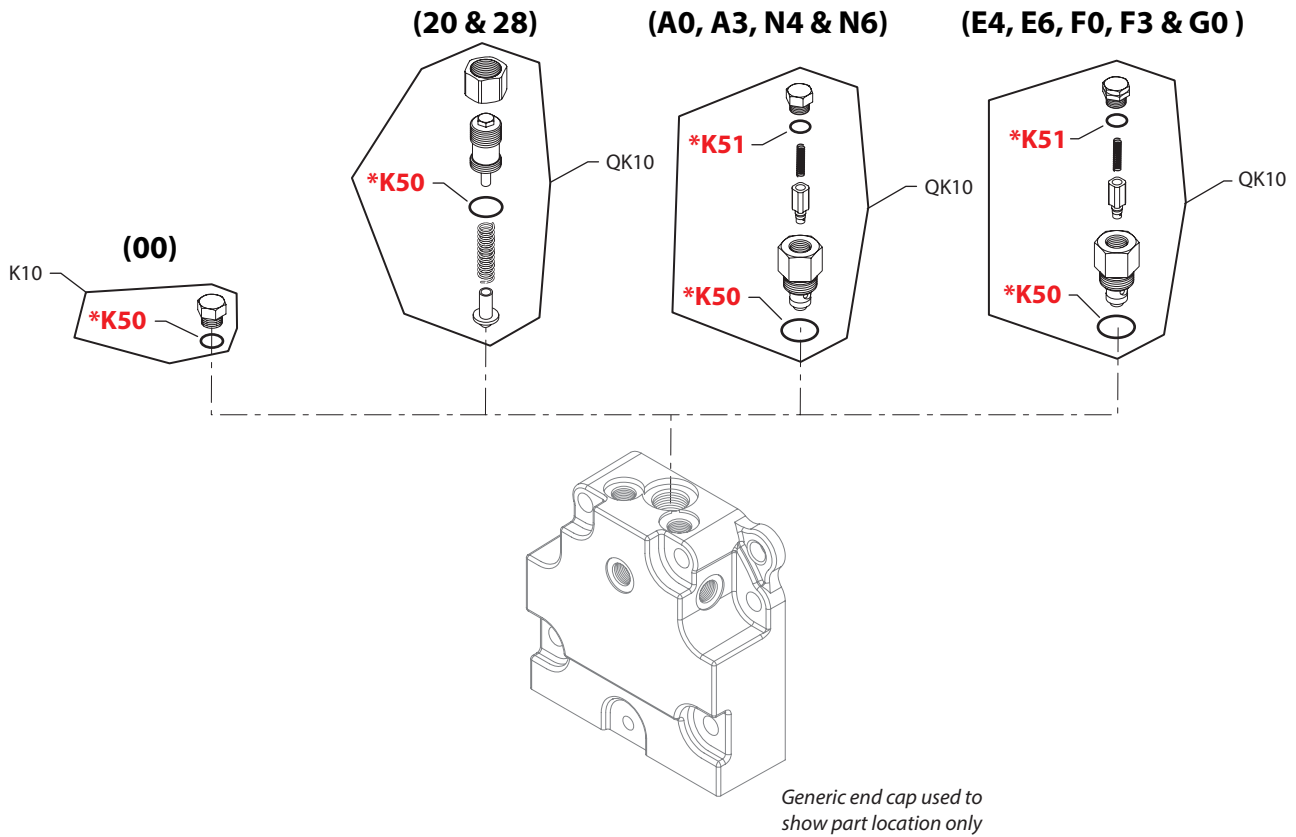

E100 823E

* = included in overhaul seal kit Q210

Enlarged **bold** type item numbers are recommended part to stock for servicing.

Fixed displacement motor
Charge pressure setting

Order Code	Item	Date Begin	Date End	Part Number	Part Name	Qty. per Model/Kit
00	K10	89-44		001537 (9005100-8700)	Plug assembly	1
	K50	89-44		001149 (9004201-6200)	O-ring	1
20-28	K000	90-20		8510012	Adjustable charge relief valve kit (SB-1989-020)	1
	K50	90-20		001149 (9004201-6200)	O-ring	1
A0	QK10	98-19		8510253	Cartridge CPRV kit, 13 bar, 11 L/min	1
	K50	98-19		001149 (9004201-6200)	O-ring	1
	K51	98-19		085043 (9004201-3700)	O-ring	2
A3	QK10	98-19		8510256	Cartridge CPRV kit, 13 bar, 16 L/min	1
	K50	98-19		001149 (9004201-6200)	O-ring	1
	K51	98-19		085043 (9004201-3700)	O-ring	2
E4	QK10	98-19		8510261	Cartridge CPRV kit, 16 bar, 4 L/min	1
	K50	98-19		001149 (9004201-6200)	O-ring	1
	K51	98-19		085043 (9004201-3700)	O-ring	2
E6	QK10	98-19		8510252	Cartridge CPRV kit, 16 bar, 7 L/min	1
	K50	98-19		001149 (9004201-6200)	O-ring	1
	K51	98-19		085043 (9004201-3700)	O-ring	2
F0	QK10	98-19		8510259	Cartridge CPRV kit, 16 bar, 11 L/min	1
	K50	98-19		001149 (9004201-6200)	O-ring	1
	K51	98-19		085043 (9004201-3700)	O-ring	2
F3	QK10	98-19		8510262	Cartridge CPRV kit, 16 bar, 16 L/min	1
	K50	98-19		001149 (9004201-6200)	O-ring	1
	K51	98-19		085043 (9004201-3700)	O-ring	2
G0	QK10	98-19		8510260	Cartridge CPRV kit, 16 bar, 22 L/min	1
	K50	98-19		001149 (9004201-6200)	O-ring	1
	K51	98-19		085043 (9004201-3700)	O-ring	2
N4	QK10	98-19		8510255	Cartridge CPRV kit, 13 bar, 4 L/min	1
	K50	98-19		001149 (9004201-6200)	O-ring	1
	K51	98-19		085043 (9004201-3700)	O-ring	2
N6	QK10	98-19		11097072	Cartridge CPRV kit, 13 bar, 7 L/min	1
	K50	98-19		001149 (9004201-6200)	O-ring	1
	K51	98-19		085043 (9004201-3700)	O-ring	2
NN				none		



Fixed displacement motor

(C6, C7, D4, E7 & S1)

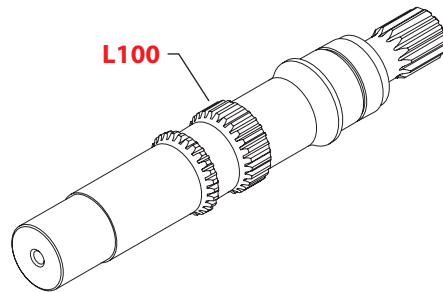

(K2 & K6)

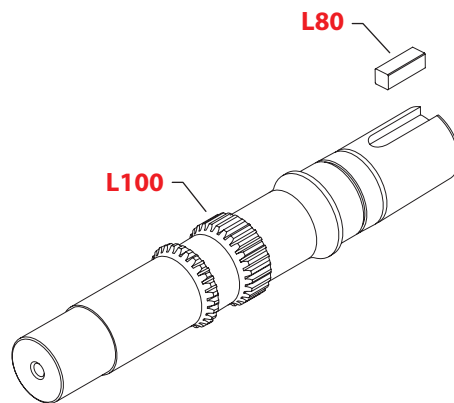

(T2)

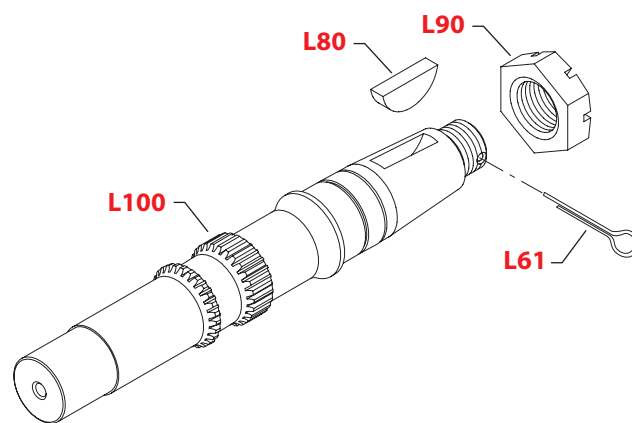

E100 774E

* = included in overhaul seal kit Q210

Enlarged **bold** type item numbers are recommended part to stock for servicing.

Fixed displacement motor
Shaft

Order Code	Item	Date Begin	Date End	Part Number	Part Name	Qty. per Model/Kit
C6	L100	87-02		11012279	Shaft, 21 tooth spline	1
C7	L100	87-02		11012280	Shaft, 23 tooth spline	1
D4	L100	87-02		11045034	Shaft, 18 tooth spline	1
E7	L100	87-02		11045035	Shaft, 23 tooth spline, tapped, M12	1
K2	L100	87-02		11012281	Shaft, straight key	1
	L80	87-02		331868 (9003261-3724)	Key, .375 x 1.5	1
K6	L100	87-02		11075453	Shaft, straight key, tapped	1
	L80	87-02		331868 (9003261-3724)	Key, .375 x 1.5	1
S1	L100	87-02		11012424	Shaft, 14 tooth spline	1
T2	L100	87-02		11012425	Shaft, tapered	1
	L61	87-02		9004600-1230	Cotter pin	1
	L80	87-02		047878 (9003310-3724)	Woodruff key, .3730 x 1.5	1
	L90	87-02		5000606	Slotted nut	1

Overhaul seal kit

Q210	87-02		11134054	Overhaul seal kit, 90MF075	
G30	87-02		8100875	End cap gasket (SB-2001-011)	1
K50	89-38		001149 (9004201-6200)	O-ring, .755 x .097, nitrile, 90D	1
K51	87-02		9004201-3700	O-ring, .468 x .078, nitrile, 90D	1
L25	87-02		519671	Seal carrier assembly	1
QB83	87-02		085043 (9004201-3700)	O-ring, .468 x .078, nitrile, 90D	2
QH50	87-02		085043 (9004201-3700)	O-ring, .468 x .078, nitrile, 90D	2



Notes



Order code, fixed displacement cartridge motor

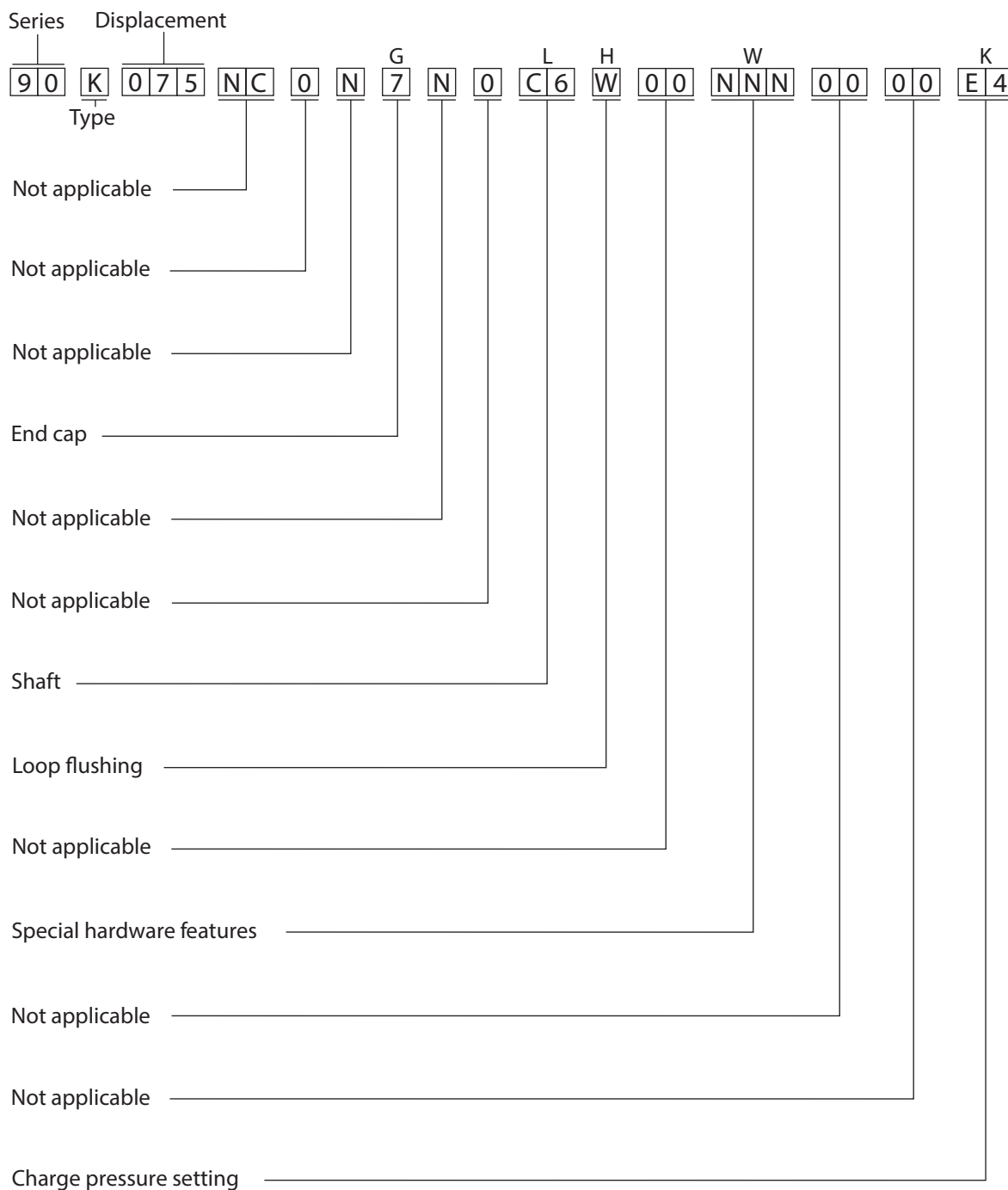

P100 708E



Fixed displacement cartridge motor

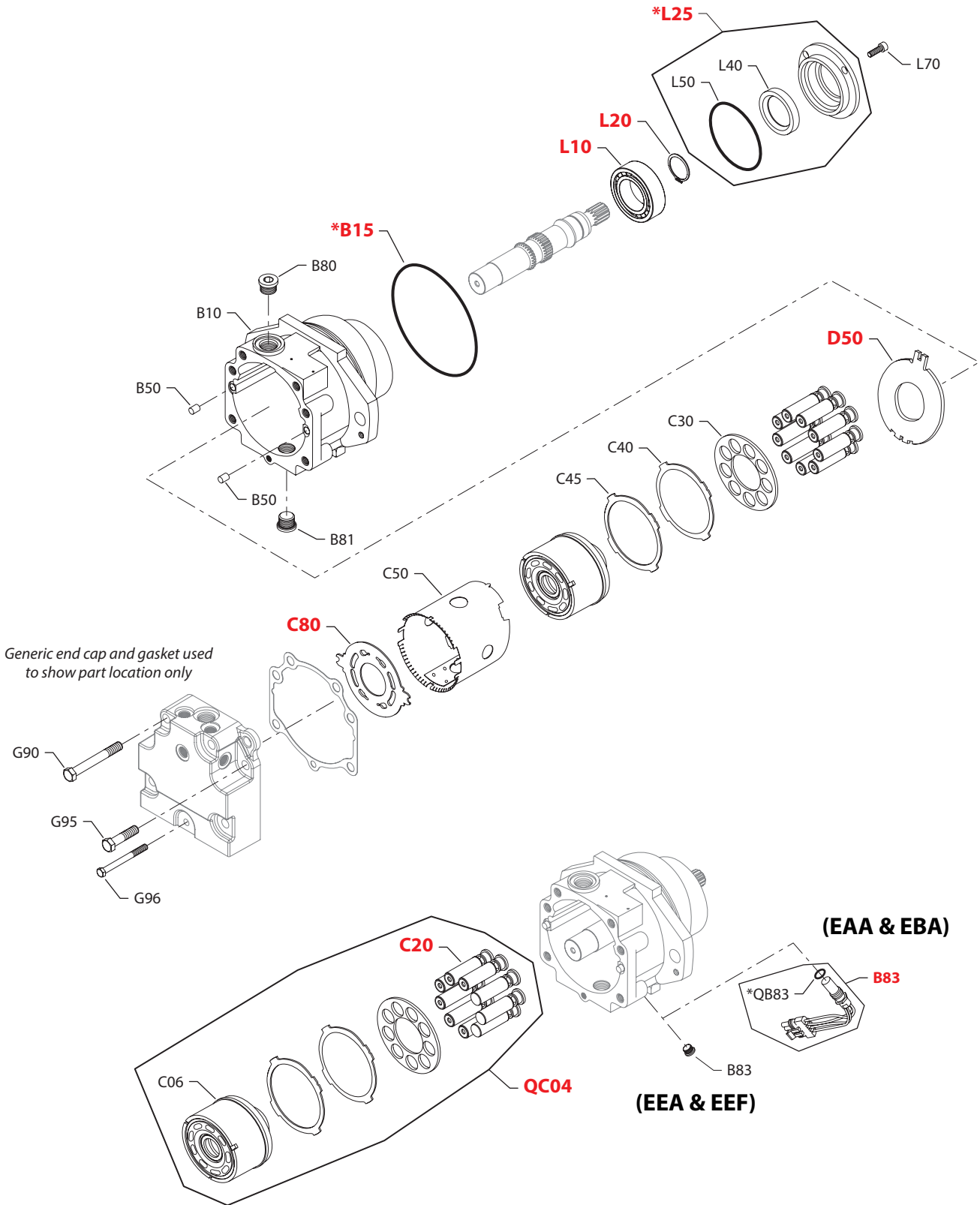

E100 824E

* = included in overhaul seal kit Q210

Enlarged **bold** type item numbers are recommended part to stock for servicing.

Fixed displacement cartridge motor
Common parts

Order Code	Item	Date Begin	Date End	Part Number	Part Name	Qty. per Model/Kit
	B10	93-07		8100860	Housing	1
	B15	93-07		502205	O-ring	1
	B50	93-07		9004800-3708	Pin	2
	B80	93-07		664524 (9005110-9000)	Plug assembly	1
	B81	93-07		664524 (9005110-9000)	Plug assembly	1
	C30	93-07		11067350	Slipper guide	1
	C40	93-07		11057797	Slipper guide retainer	1
	C45	93-07		11063828	Slipper guide retainer spacer	1
	C50	93-07		8100475	Hold down tube	1
	C80	93-07		323766	Valve plate	1
	D50	93-07		11136452	Thrust plate	1
	G90	93-07		9007210-1216	Screw	4
	G95	93-07		675900 (9007210-1209)	Screw	2
	G96	93-07		9007210-1016	Screw	1
	L10	93-07		5000505	Roller beraing	1
	L20	93-07		9006300-0156	Retaining ring	1
	L25	93-07		8100554	Seal assembly	1
	L40	93-07		519666	Lip seal	1
	L50	93-07		071845 (9004104-1520)	O-ring	1
	L70	93-07		041160 (9007314-0605)	Screw	3

Special hardware

EAA	B83	87-02		KPPG12508	Speed sensor assembly	1
	C06	87-02		11011714	Cylinder block assy. w/speed ring (SB-2005-018)	1
	C20	87-02		708230	Piston assembly (SB-1988-023)	9
	QB83	87-02		085043 (9004201-3700)	O-ring	1
	QC04	87-02		8510367	Cylinder block kit w/speed ring	1
EBA	B83	93-07		KPPG13408	Speed sensor	1
	C06	87-02		11011714	Cylinder block assy. w/speed ring (SB-2005-018)	1
	C20	87-02		708230	Piston assembly (SB-1988-023)	9
	QB83	93-07		085043 (9004201-3700)	O-ring	1
	QC04	87-02		8510367	Cylinder block kit w/speed ring	1
EEA	B83	93-07		140644	Plug assembly	1
	C06	87-02		11011714	Cylinder block assy. w/speed ring (SB-2005-018)	1
	C20	87-02		708230	Piston assembly (SB-1988-023)	9
	QC04	87-02		8510367	Cylinder block kit w/speed ring	1
EEF	B83	93-07		140644	Plug assembly	1
	C06	87-02		11011768	Cylinder block assembly w/impulse speed ring	1
	C20	87-02		708230	Piston assembly (SB-1988-023)	9
	QC04	87-02		11137421	Cylinder block kit w/impulse speed ring	1



Fixed displacement cartridge motor

(EGG, EGJ & EGK)

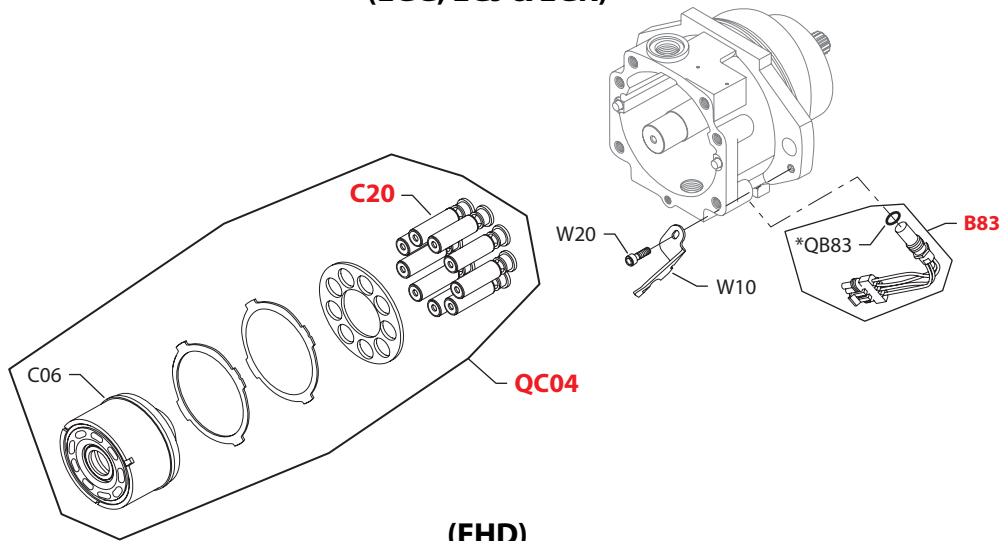

(EHD)

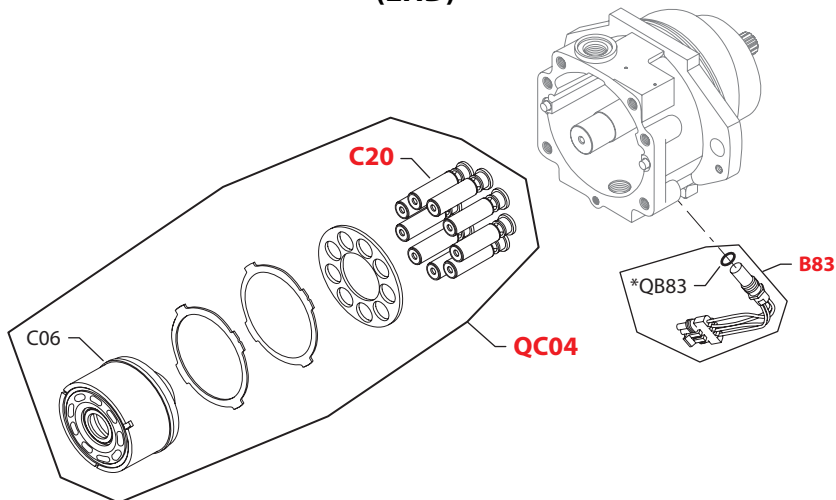

(JAD & NNN)

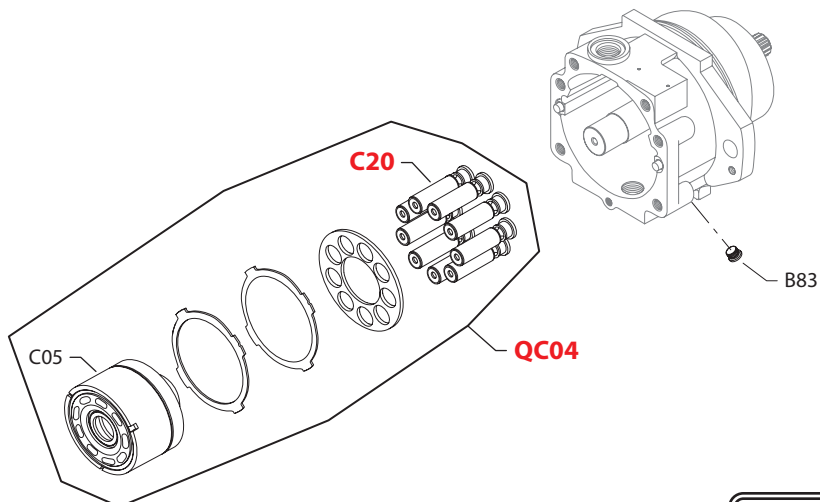

* = included in overhaul seal kit Q210

E100 825E

Enlarged **bold** type item numbers are recommended part to stock for servicing.

Fixed displacement cartridge motor
Special hardware

Order Code	Item	Date Begin	Date End	Part Number	Part Name	Qty. per Model/Kit
EGG	C06	01-11		11011714	Cylinder block assembly w/speed ring	1
	C20	01-11		708230	Piston assembly	9
	B83	01-11		KPPG17708	Speed sensor	1
	QB83	01-11		085043 (9004201-3700)	O-ring	1
	QC04	01-11		8510367	Cylinder block kit w/speed ring	1
	W10	01-11		8100861	Speed sensor bracket	1
	W20	01-11		067637	Screw	1
	EGJ	C06	05-44		11011714	Cylinder block assembly w/speed ring
C20		05-44		708230	Piston assembly	9
B83		05-44		KPPG19708	Speed sensor	1
QB83		05-44		085043 (9004201-3700)	O-ring	1
QC04		05-44		8510367	Cylinder block kit w/speed ring	1
W10		05-44		8100861	Speed sensor bracket	1
W20		05-44		067637	Screw	1
EGK		C06	06-12		11011714	Cylinder block assembly w/speed ring
	C20	06-12		708230	Piston assembly	9
	B83	06-12		KPPG17708	Speed sensor	1
	QB83	06-12		085043 (9004201-3700)	O-ring	1
	QC04	06-12		8510367	Cylinder block kit w/speed ring	1
	W10	06-12		8100861	Speed sensor bracket	1
	W20	06-12		067637	Screw	1
	EHD	C06	08-12		11011714	Cylinder block assembly w/speed ring
C20		08-12		708230	Piston assembly	9
B83		08-12		KPPG16408	Speed sensor	1
QB83		08-12		085043 (9004201-3700)	O-ring	1
QC04		08-12		8510367	Cylinder block kit w/speed ring	1
JAD		B83	06-16		140644	Plug assembly
	C05	06-16		11025822	Cylinder block assembly w/o speed ring	1
	C20	06-16		708230	Piston assembly	9
	QC04	06-16		8510364	Cylinder block kit, w/o speed ring	1
NNN	B83	93-07		140644	Plug assembly	1
	C05	93-07		11025822	Cylinder block assembly w/o speed ring	1
	C20	93-07		708230	Piston assembly	9
	QC04	93-07		8510364	Cylinder block kit, w/o speed ring	1



Fixed displacement cartridge motor

(1, 8, & D)

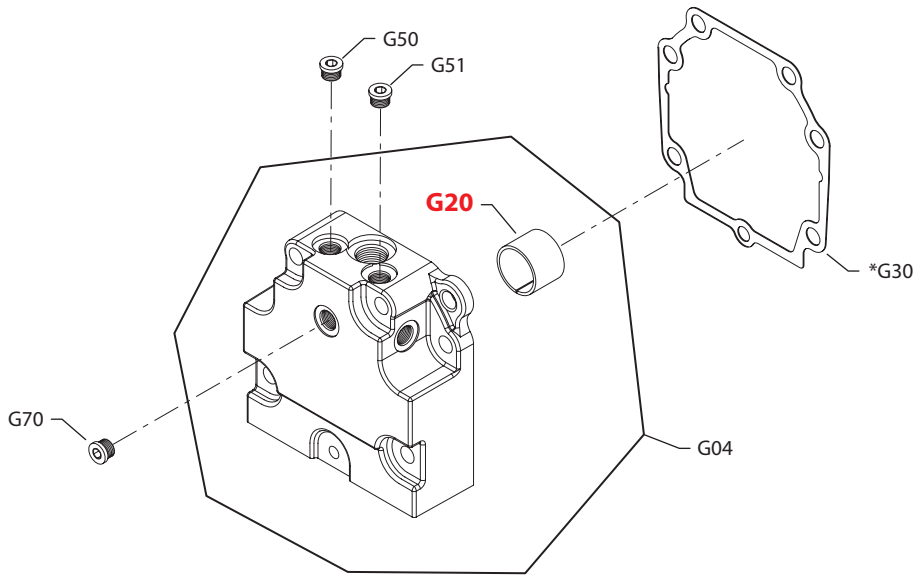

(3 & 7)

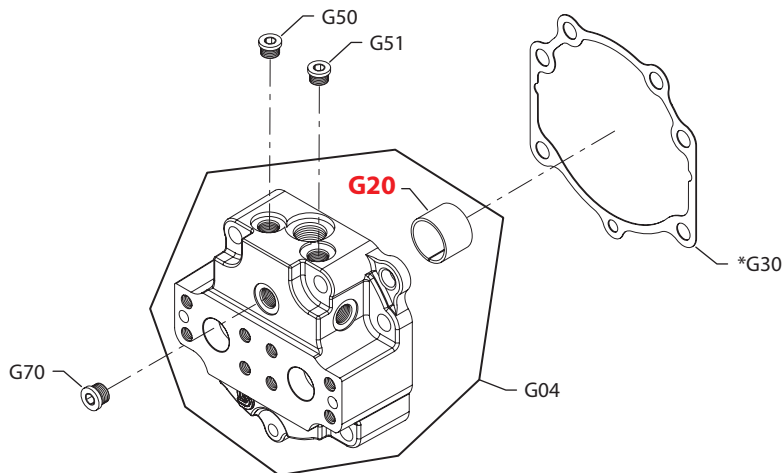

E100.835E

* = included in overhaul seal kit Q210

Enlarged **bold** type item numbers are recommended part to stock for servicing.



Fixed displacement cartridge motor
End cap

Order Code	Item	Date Begin	Date End	Part Number	Part Name	Qty. per Model/Kit
1	G04	98-34	15-22	8100967 (8100733)	End cap assy., twin ports (SB-1989-020 & 1998-007)	1
	G20	87-02	15-22	11017393 (8700013)	Journal bearing	1
	G50	87-02	15-22	140644	Plug assembly	1
	G51	87-02	15-22	140644	Plug assembly	1
	G70	87-02	15-22	140644	Plug assembly	1
3	G04	98-34	15-22	8100968 (8100734)	End cap assy., axial ports (SB-1989-020 & 1998-007)	1
	G20	87-02	15-22	11017393 (8700013)	Journal bearing	1
	G50	87-02	15-22	140644	Plug assembly	1
	G51	87-02	15-22	140644	Plug assembly	1
	G70	87-02	15-22	140644	Plug assembly	1
7	G04	98-34		8100968 (8100734)	End cap assy., axial ports (SB-1989-020 & 1998-007)	1
	G20	87-02		11017393 (8700013)	Journal bearing	1
	G50	87-02		140644	Plug assembly	1
	G51	87-02		140644	Plug assembly	1
	G70	87-02		140644	Plug assembly	1
8	G04	98-34		8100967 (8100733)	End cap assy., twin ports (SB-1989-020 & 1998-007)	1
	G20	87-02		11017393 (8700013)	Journal bearing	1
	G50	87-02		140644	Plug assembly	1
	G51	87-02		140644	Plug assembly	1
	G70	87-02		140644	Plug assembly	1
D	G04	98-34		8100966 (8100731)	End cap assembly, twin metric ports (SB-1998-007)	1
	G20	95-40		11017393 (8700013)	Journal bearing	1
	G50	95-40		140644	Plug assembly	1
	G51	95-40		140644	Plug assembly	1
	G70	95-40		140644	Plug assembly	1

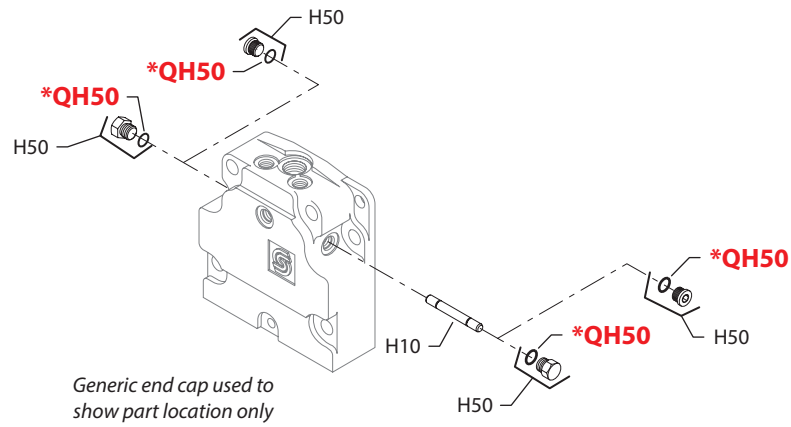

Fixed displacement cartridge motor

(N)



(W)

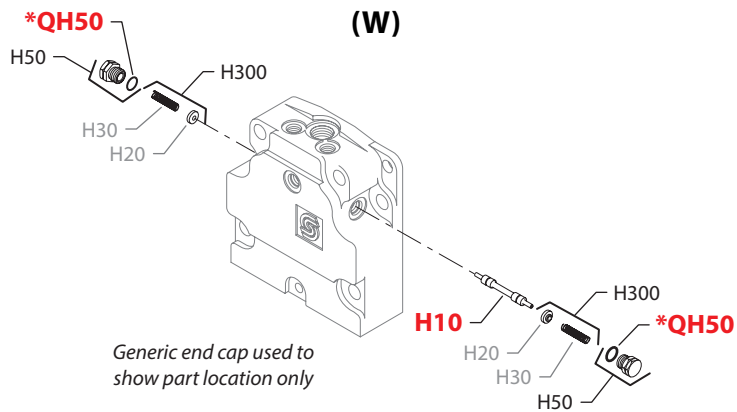

E100 773E

* = included in overhaul seal kit Q210

Enlarged **bold** type item numbers are recommended part to stock for servicing.

Fixed displacement cartridge motor
Loop flushing

Order Code	Item	Date Begin	Date End	Part Number	Part Name	Qty. per Model/Kit
N	H10	89-38		8800668	Loop flushing spool, defeated	1
	H10	87-02	89-37	8800021	Loop flushing spool, defeated (SB-1989-020)	1
	H50	87-02		140644	Plug assembly	2
	QH50	87-02		085043 (9004201-3700)	O-ring	2
W	H10	89-38		1118733	Shuttle spool	1
	H10	89-38	89-37	674473 (8800069)	Loop flushing spool, defeated (SB-1989-020)	1
	H20	87-02	89-37	8800265	Spring guide (SB-1989-020)	2
	H30	87-02	89-37	8800067	Spring (SB-1989-020)	2
	H50	89-38		518016	Plug assembly	2
	H50	87-02	89-37	9005475-0069	Plug assembly (SB-1989-020)	2
	H300	89-38		513596	Spring guide assembly (SB-2000-047)	2
	QH50	87-02		085043 (9004201-3700)	O-ring	2



Fixed displacement cartridge motor

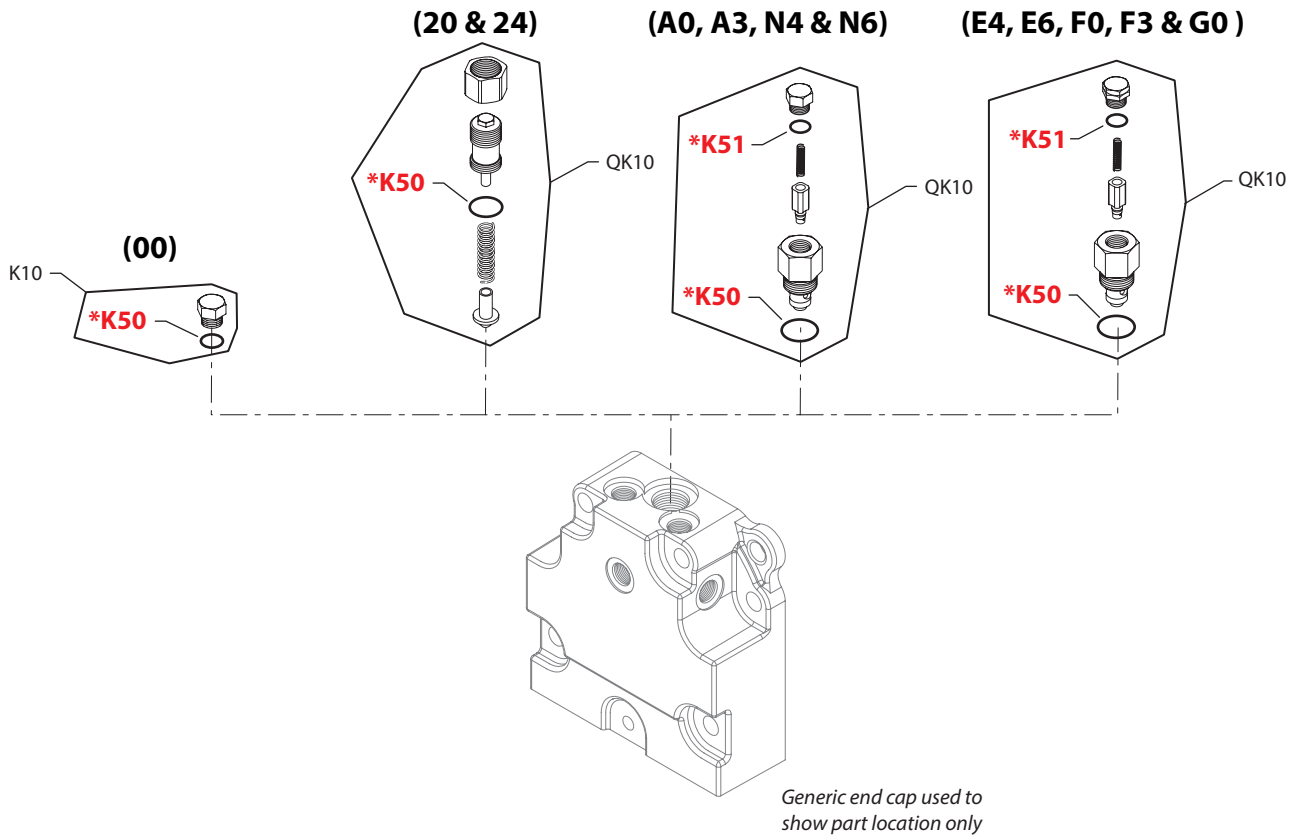

E100 823E

* = included in overhaul seal kit Q210

Enlarged **bold** type item numbers are recommended part to stock for servicing.

Fixed displacement cartridge motor
Charge pressure setting

Order Code	Item	Date Begin	Date End	Part Number	Part Name	Qty. per Model/Kit
00	K10	89-44		001537 (9005100-8700)	Plug assembly	1
	K50	89-44		001149 (9004201-6200)	O-ring	1
20-24	K000	90-20		8510012	Adjustable charge relief valve kit (SB-1989-020)	1
	K50	90-20		001149 (9004201-6200)	O-ring	1
A0	QK10	98-19		8510253	Cartridge CPRV kit, 13 bar, 11 L/min	1
	K50	98-19		001149 (9004201-6200)	O-ring	1
	K51	98-19		085043 (9004201-3700)	O-ring	2
A3	QK10	98-19		8510256	Cartridge CPRV kit, 13 bar, 16 L/min	1
	K50	98-19		001149 (9004201-6200)	O-ring	1
	K51	98-19		085043 (9004201-3700)	O-ring	2
E4	QK10	98-19		8510261	Cartridge CPRV kit, 16 bar, 4 L/min	1
	K50	98-19		001149 (9004201-6200)	O-ring	1
	K51	98-19		085043 (9004201-3700)	O-ring	2
E6	QK10	98-19		8510252	Cartridge CPRV kit, 16 bar, 7 L/min	1
	K50	98-19		001149 (9004201-6200)	O-ring	1
	K51	98-19		085043 (9004201-3700)	O-ring	2
F0	QK10	98-19		8510259	Cartridge CPRV kit, 16 bar, 11 L/min	1
	K50	98-19		001149 (9004201-6200)	O-ring	1
	K51	98-19		085043 (9004201-3700)	O-ring	2
F3	QK10	98-19		8510262	Cartridge CPRV kit, 16 bar, 16 L/min	1
	K50	98-19		001149 (9004201-6200)	O-ring	1
	K51	98-19		085043 (9004201-3700)	O-ring	2
G0	QK10	98-19		8510260	Cartridge CPRV kit, 16 bar, 22 L/min	1
	K50	98-19		001149 (9004201-6200)	O-ring	1
	K51	98-19		085043 (9004201-3700)	O-ring	2
N4	QK10	98-19		8510255	Cartridge CPRV kit, 13 bar, 4 L/min	1
	K50	98-19		001149 (9004201-6200)	O-ring	1
	K51	98-19		085043 (9004201-3700)	O-ring	2
N6	QK10	98-19		11097072	Cartridge CPRV kit, 13 bar, 7 L/min	1
	K50	98-19		001149 (9004201-6200)	O-ring	1
	K51	98-19		085043 (9004201-3700)	O-ring	2
NN				none		



Fixed displacement cartridge motor

(C6, C7 & S1)

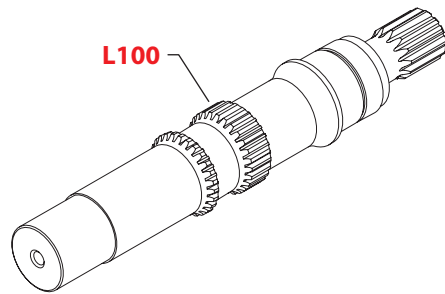

(K2)

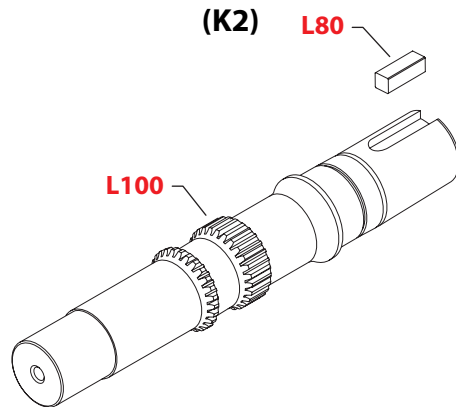

(T2)

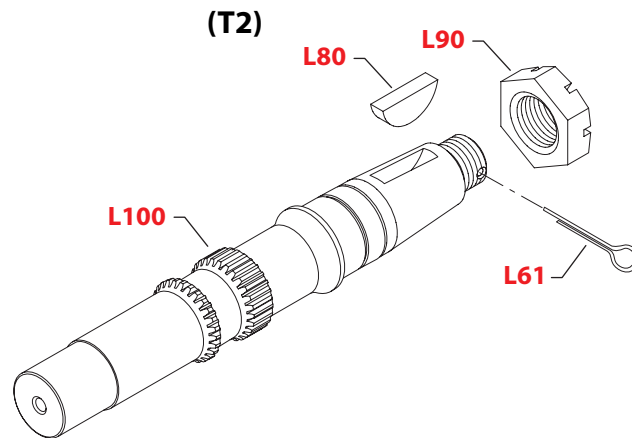

E100 774E

* = included in overhaul seal kit Q210

Enlarged **bold** type item numbers are recommended part to stock for servicing.

Fixed displacement cartridge motor
Shaft

Order Code	Item	Date Begin	Date End	Part Number	Part Name	Qty. per Model/Kit
C6	L100	93-07		11012279	Shaft, 21 tooth spline, 16/32	1
C7	L100	93-07		11012280	Shaft, 23 tooth spline, 16/32	1
K2	L100	93-07		11012281	Shaft, straight key	1
	L80	93-07		331868 (9003261-3724)	Key, .375 x 1.5	1
S1	L100	93-07		11012424	Shaft, 14 tooth spline, 12/24	1
T2	L100	93-07		11012425	Shaft, tapered	1
	L61	93-07		9004600-1230	Cotter pin	1
	L80	93-07		047878 (9003310-3724)	Woodruff key, .3730 x 1.5	1
	L90	93-07		5000606	Slotted nut	1

Overhaul seal kit

Q210	93-07		11141342	Overhaul seal kit, 90MFC075	
B15	93-07		502205	O-ring	1
G30	93-07		8100874	End cap gasket (SB-2001-011)	1
G30	93-07		8100875	End cap gasket (SB-2001-011)	1
K50	93-07		001149 (9004201-6200)	O-ring	1
K51	93-07		085043 (9004201-3700)	O-ring	1
L25	93-07		8100554	Seal carrier assembly	1
QB83	93-07		085043 (9004201-3700)	O-ring	1
QH50	93-07		085043 (9004201-3700)	O-ring	2



Notes



Order code, variable displacement motor

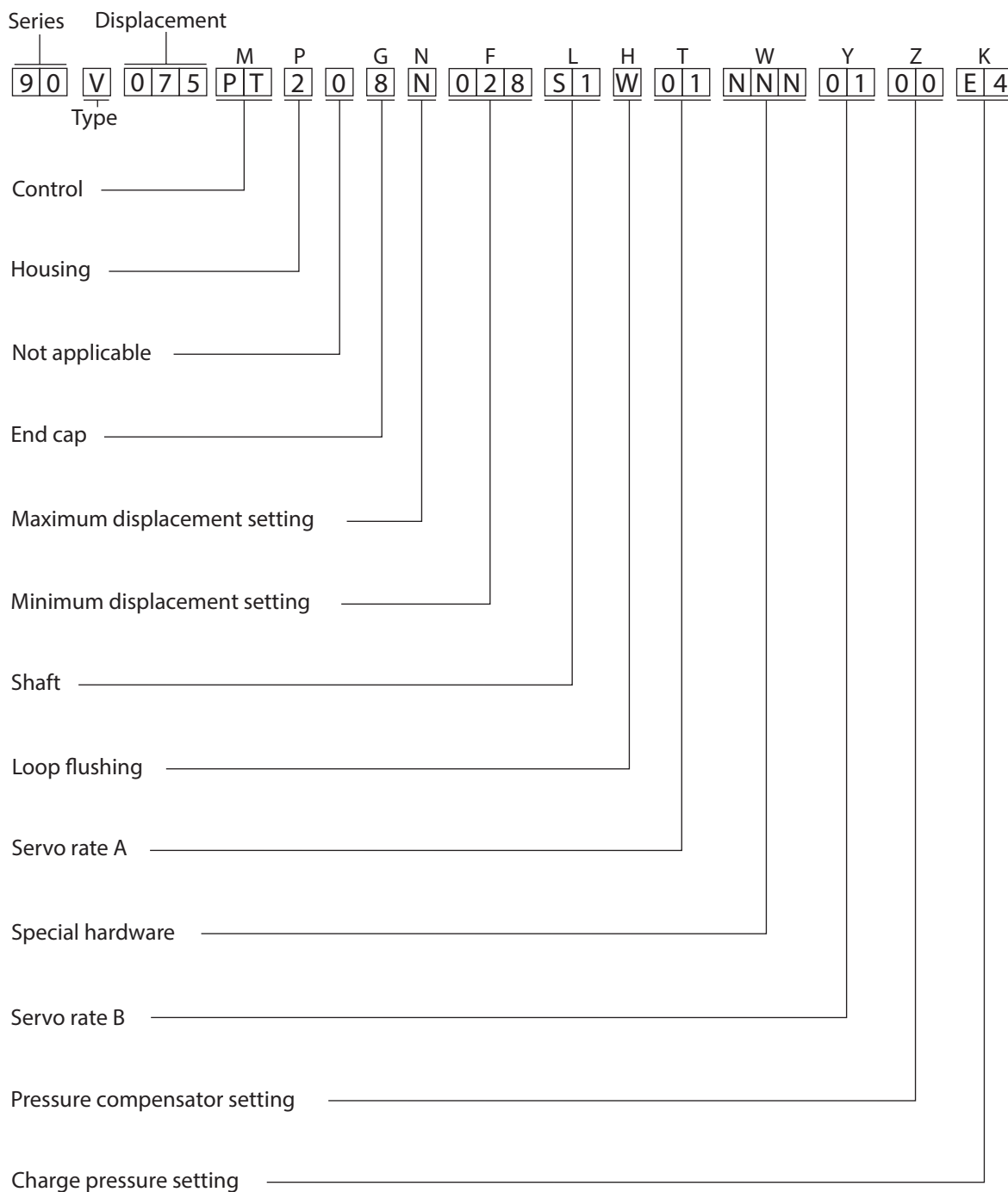

P100 707E



Variable displacement motor

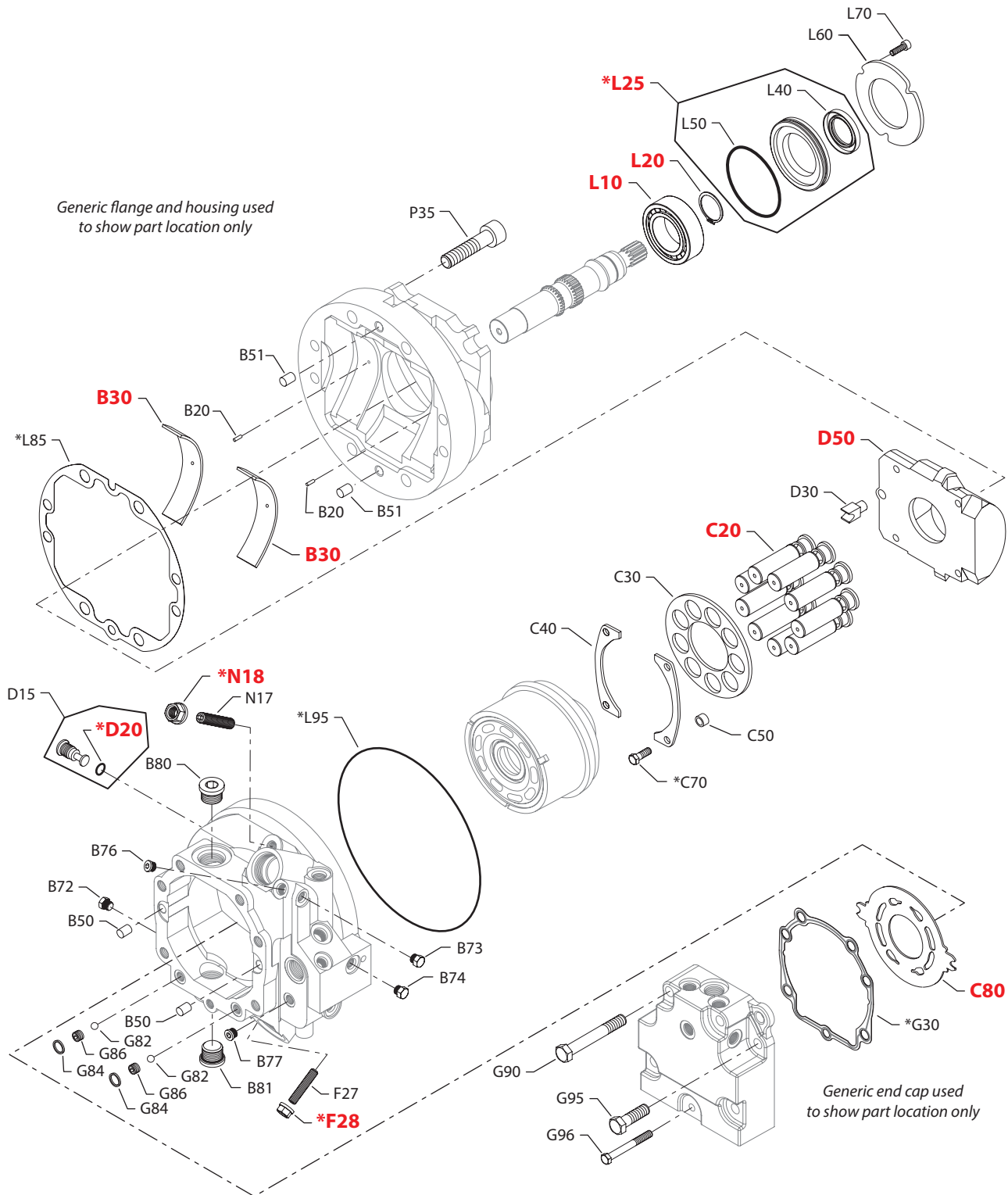

E100 781E

* = included in overhaul seal kit Q210

Enlarged **bold** type item numbers are recommended part to stock for servicing.

Variable displacement motor
Common parts

Order Code	Item	Date Begin	Date End	Part Number	Part Name	Qty. per Model/Kit
	B20	93-07		5000621	Grooved pin (SB-2000-046)	2
	B30	93-07		8100684	Cradle bearing	2
	B50	93-07		9004800-3708	Pin	2
	B51	93-07		9004800-3708	Pin	2
	B72	93-07		001511 (9005100-4400)	Plug assembly	1
	B73	93-07		001511 (9005100-4400)	Plug assembly	1
	B74	93-07		001511 (9005100-4400)	Plug assembly	1
	B76	93-07		327007 (9005110-4400)	Plug assembly	1
	B77	93-07		327007 (9005110-4400)	Plug assembly	1
	B80	93-07		664524 (9005110-9000)	Plug assembly	1
	B81	93-07		664524 (9005110-9000)	Plug assembly	1
	C20	93-07		708230	Piston assembly (SB-1988-023)	9
	C30	93-07		11067350	Slipper guide	1
	C40	93-07		8100294	Slipper guide bearing	2
	C50	93-07		11065865	Slipper holddown spacer (SB-1998-041)	4
	C65	93-07	98-47	Obsolete	Washer (SB-1998-041)	4
	C70	93-07		9007276-0114	Screw (SB-1998-041)	4
	C80	93-07		323766	Valve plate	1
	D15	93-07		11056875	Hold down pin assembly (SB-1994-024)	1
	D20	93-07		085043 (9004201-3700)	O-ring	1
	D30	93-07		8100406	Hold down arm	1
	D50	93-07		8100928	Swashplate (SB-1998-080)	1
	F27	93-07		330415	Set screw	1
	F28	93-07		9003509-0012	Seal nut	1
	G30	93-07		8100430	End cap gasket	1
	G82	93-07		9001214-2800	Ball	2
	G84	93-07		8800865	Crush ring	2
	G86	93-07		11066594	Orifice plug	2
	G90	93-07		9007210-1216	Screw	4
	G95	93-07		9007210-1209	Screw	2
	G96	93-07		9007210-1016	Screw	1
	L10	93-07		5000505	Roller bearing	1
	L20	93-07		9006300-0156	Retaining ring	1
	L25	93-07		519671	Seal assembly (SB-2006-012)	1
	L40	93-07		519666	Lip seal (SB-2006-012)	1
	L50	93-07		684621 (9004104-1530)	O-ring	1
	L60	93-07		516767	Retainer plate	1
	L70	93-07		041160 (9007314-0605)	Screw	3
	L85	93-07		8100423	Front cover gasket	1
	L95	93-07		9004104-1710	O-ring	1
	N17	93-07		330415	Screw	1
	N18	93-07		9003509-0012	Seal nut	1
	P35	93-07		9007314-1211	Screw	4



Variable displacement motor

Generic housing used to show part location only

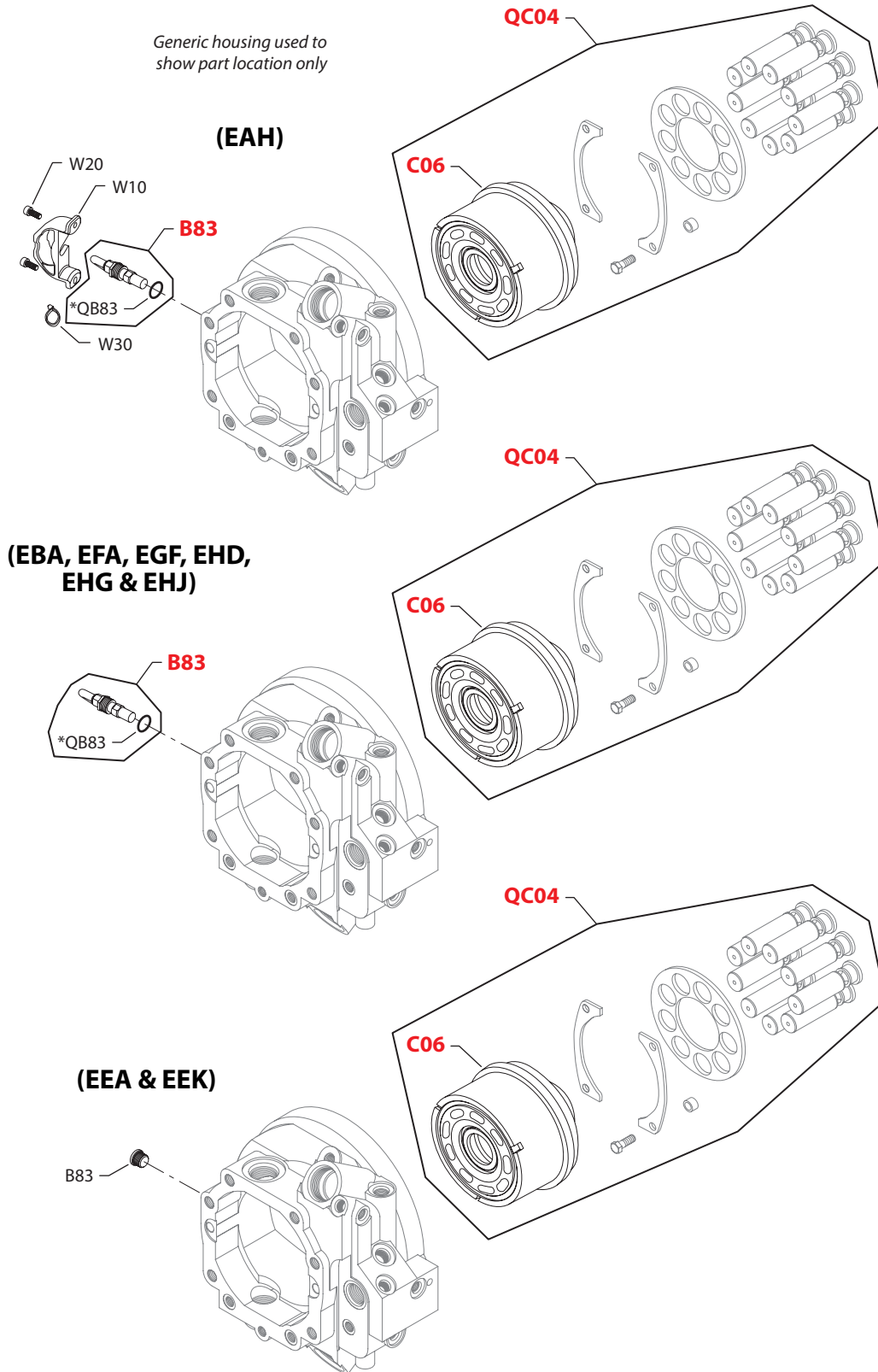

E100 827E

* = included in overhaul seal kit Q210

Enlarged **bold** type item numbers are recommended part to stock for servicing.

Variable displacement motor
Special hardware

Order Code	Item	Date Begin	Date End	Part Number	Part Name	Qty. per Model/Kit
EAH	B83	06-12		11046858	Speed sensor	1
	C06	06-12		11011714	Cylinder block assembly w/speed ring	1
	QC04	06-12		8510366	Cylinder block kit w/speed ring	1
	QB83	06-12		085043 (9004201-3700)	O-ring	1
	W10	06-12		8801261	Speed sensor cover	1
	W20	06-12		067637	Screw	2
	W30	06-12		5000509	Cable tie	1
EBA	B83	94-44		KPPG13408	Speed sensor	1
	C06	94-44		11011714	Cylinder block assy. w/speed ring (SB-2005-018)	1
	QB83	94-44		085043 (9004201-3700)	O-ring	1
	QC04	94-44		8510366	Cylinder block kit w/speed ring (SB-2005-018)	1
EEA	B83	94-36		140644	Plug assembly	1
	C06	94-36		11011714	Cylinder block assy. w/speed ring (SB-2005-018)	1
	QC04	94-36		8510366	Cylinder block kit w/speed ring (SB-2005-018)	1
EEK	B83	06-12		140644	Plug assembly	1
	C06	06-12		11011714	Cylinder block assembly w/speed ring	1
	QC04	06-12		8510366	Cylinder block kit w/speed ring	1
EFA	B83	94-36		KPPG136	Speed sensor	1
	C06	94-36		11011714	Cylinder block assy. w/speed ring (SB-2005-018)	1
	QB83	94-36		085043 (9004201-3700)	O-ring	1
	QC04	94-36		8510366	Cylinder block kit w/speed ring (SB-2005-018)	1
EGF	B83	01-40		KPPG13703	Speed sensor	1
	C06	01-40		11011714	Cylinder block assy. w/speed ring (SB-2005-018)	1
	QB83	01-40		085043 (9004201-3700)	O-ring	1
	QC04	01-40		8510366	Cylinder block kit w/speed ring (SB-2005-018)	1
EHD	B83	96-43		KPPG16408	Speed sensor	1
	C06	96-43		11011714	Cylinder block assembly w/speed ring	1
	QB83	96-43		085043 (9004201-3700)	O-ring	1
	QC04	96-43		8510366	Cylinder block kit w/speed ring	1
EHG	B83	06-12		KPPG16408	Speed sensor	1
	C06	06-12		11011714	Cylinder block assembly w/speed ring	1
	QB83	06-12		085043 (9004201-3700)	O-ring	1
	QC04	06-12		8510366	Cylinder block kit w/speed ring	1
EHJ	B83	06-12		KPPG16408	Speed sensor	1
	C06	06-12		11011714	Cylinder block assembly w/speed ring	1
	QB83	06-12		085043 (9004201-3700)	O-ring	1
	QC04	06-12		8510366	Cylinder block kit w/speed ring	1



Variable displacement motor

(JAF, JAG, JAK & NNN)

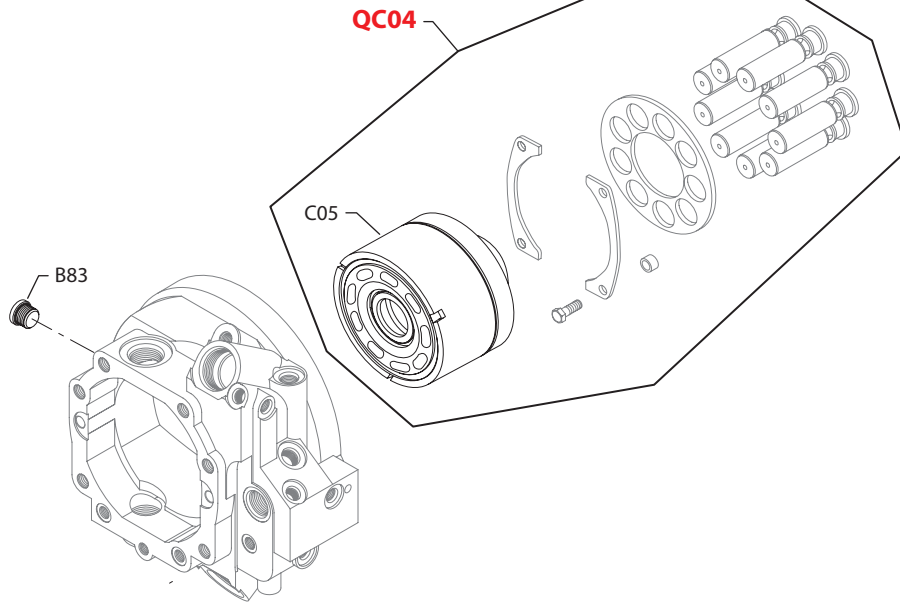

Generic housing used to show part location only

(026-054)

(M32)

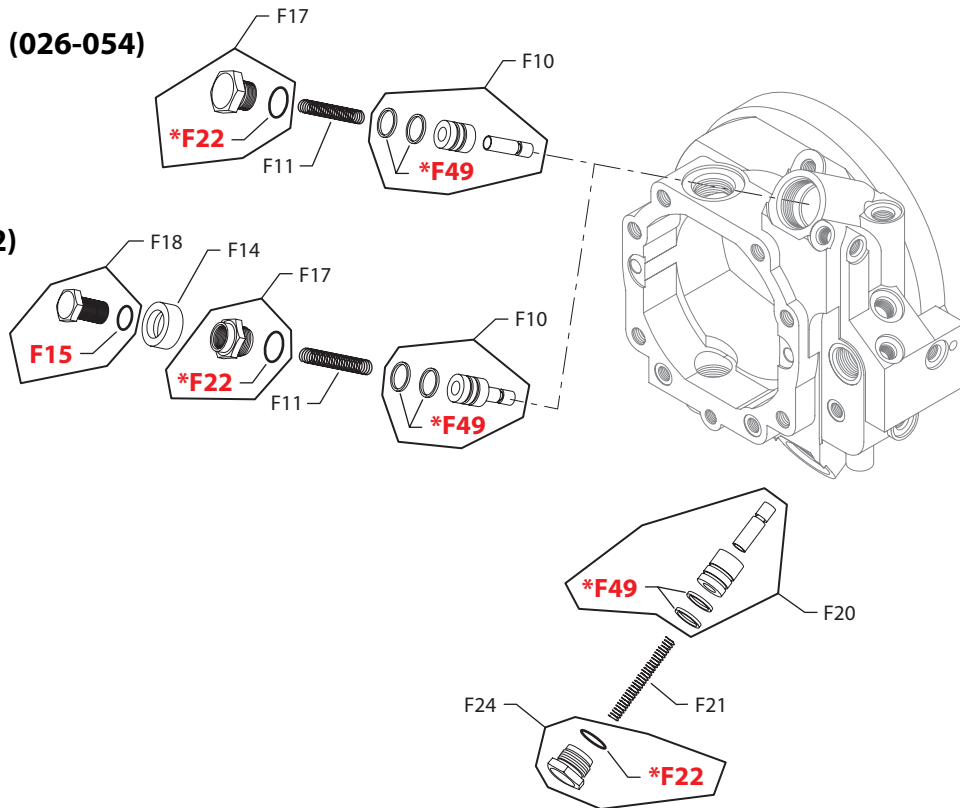

E100 828E

* = included in overhaul seal kit Q210

Enlarged **bold** type item numbers are recommended part to stock for servicing.

Variable displacement motor
Special hardware

Order Code	Item	Date Begin	Date End	Part Number	Part Name	Qty. per Model/Kit
JAF	B83	06-12		140644	Plug assembly	1
	C05	06-12		11025822	Cylinder block assembly. w/o speed ring	1
	QC04	06-12		8510365	Cylinder block kit, w/o speed ring	1
JAG	B83	06-12		140644	Plug assembly	1
	C05	06-12		11025822	Cylinder block assembly. w/o speed ring	1
	QC04	06-12		8510365	Cylinder block kit, w/o speed ring	1
JAK	B83	06-12		140644	Plug assembly	1
	C05	06-12		11025822	Cylinder block assembly. w/o speed ring	1
	QC04	06-12		8510365	Cylinder block kit, w/o speed ring	1
NNN	B83	93-07		140644	Plug assembly	1
	C05	93-07		11025822	Cylinder block assembly. w/o speed ring	1
	QC04	93-07		8510365	Cylinder block kit, w/o speed ring	1

Minimum displacement

026 - 054	F10	90-34		8100441	Servo piston assembly	1
	F11	90-34		8800619	Spring	1
	F17	90-34		11056796	Plug. special assembly	1
	F20	90-34		8100441	Servo piston assembly	1
	F21	90-34		8100435	Spring	1
	F22	90-34		038281	O-ring	2
	F24	90-34		11056796	Plug. special assembly	1
	F49	90-34		8700089	Piston seal ring	4
	M32	F10	99-24	13-26	8801165	Servo piston assembly
F11		99-24	13-26	8801161	Spring	1
F14		99-24	13-26	8801214	Servo shield	1
F15		99-24	13-26	012559 (9004202-6200)	O-ring	1
F17		99-24	13-26	11056797	Fitting assembly	1
F18		99-24	13-26	11056777	Servo plug assembly	1
F20		99-24	13-26	8801165	Servo piston assembly	1
F21		99-24	13-26	8801160	Spring	1
F22		99-24	13-26	038281	O-ring	2
F24		99-24	13-26	11056783	Plug. special	1
F49		99-24	13-26	8700089	Piston seal ring	4



Variable displacement motor

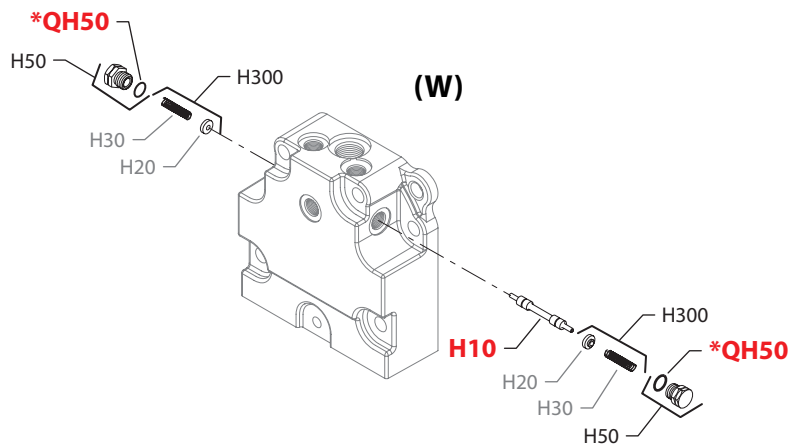
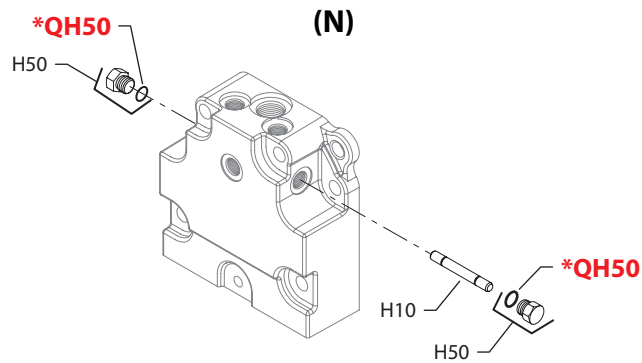
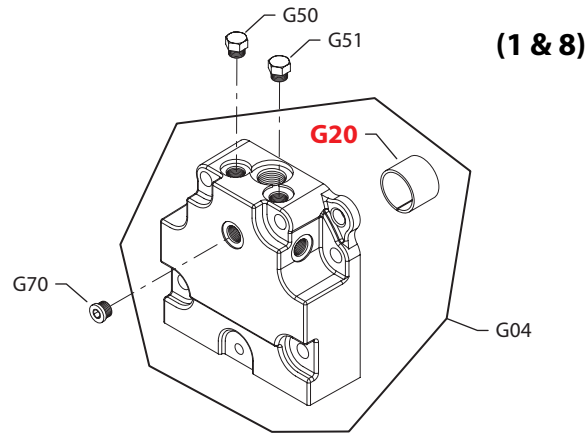

* = included in overhaul seal kit Q210

E100 829E

Enlarged **bold** type item numbers are recommended part to stock for servicing.

Variable displacement motor
End cap

Order Code	Item	Date Begin	Date End	Part Number	Part Name	Qty. per Model/Kit
1	G04	93-07		8100737	End cap assembly, twin ports	1
	G20	93-07		8700013	Journal bearing	1
	G50	93-07		046151 (9005100-5600)	Plug assembly	1
	G51	93-07		046151 (9005100-5600)	Plug assembly	1
	G70	93-07		140644	Plug assembly	1
8	G04	93-07		8100737	End cap assembly, twin ports	1
	G20	93-07		8700013	Journal bearing	1
	G50	93-07		046151 (9005100-5600)	Plug assembly	1
	G51	93-07		046151 (9005100-5600)	Plug assembly	1
	G70	93-07		140644	Plug assembly	1

Loop flushing

N	H10	93-07		8800668	Loop flushing spool, defeated	1
	H50	93-07		046151 (9005100-5600)	Plug assembly	2
	QH50	93-07		085043 (9004201-3700)	O-ring	2
W	H10	93-07		8800550	Shuttle spool	1
	H50	93-07		518016	Plug assembly	2
	H300	93-07		513596	Spring guide assembly (SB-2000-047)	2
	QH50	93-07		085043 (9004201-3700)	O-ring	2



Variable displacement motor

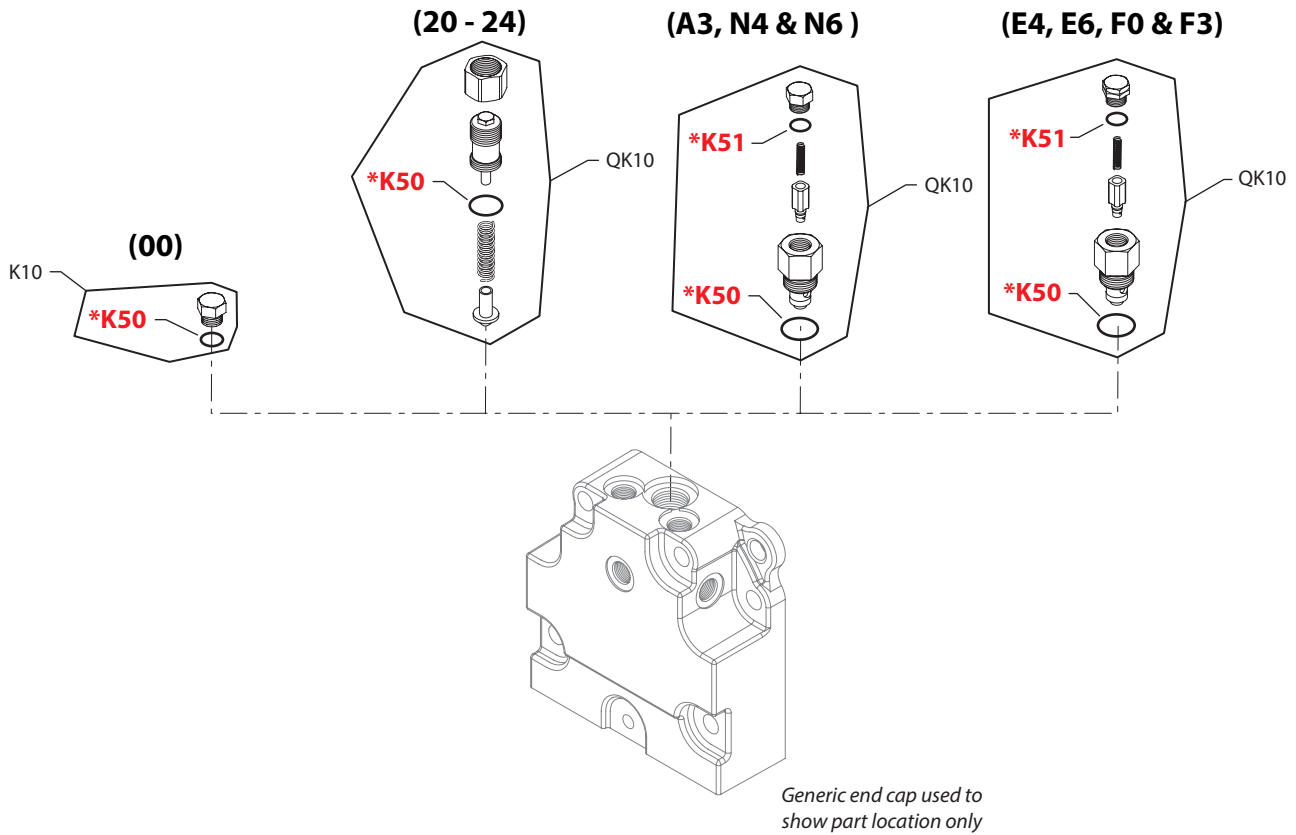

(C9 & S1)

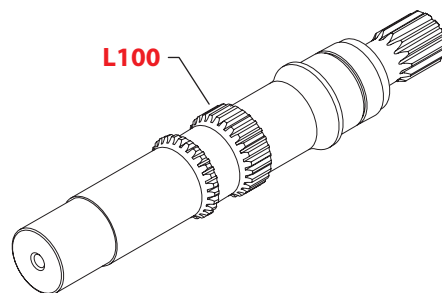

* = included in overhaul seal kit Q210

E100 830E

Enlarged **bold** type item numbers are recommended part to stock for servicing.

Variable displacement motor
Charge pressure setting

Order Code	Item	Date Begin	Date End	Part Number	Part Name	Qty. per Model/Kit
00	K10	93-07		001537 (9005100-8700)	Plug assembly	1
	K50	93-07		001149 (9004201-6200)	O-ring	1
20-24	QK10	93-07		8510012	Adjustable charge relief valve kit	1
	K50	93-07		001149 (9004201-6200)	O-ring	1
A3	QK10	93-07		8510256	Cartridge CPRV kit, 13 bar, 16 L/min	1
	K50	93-07		001149 (9004201-6200)	O-ring	1
	K51	93-07		085043 (9004201-3700)	O-ring	2
E4	QK10	93-07		8510261	Cartridge CPRV kit, 16 bar, 4 L/min	1
	K50	93-07		001149 (9004201-6200)	O-ring	1
	K51	93-07		085043 (9004201-3700)	O-ring	2
E6	QK10	93-07		8510252	Cartridge CPRV kit, 16 bar, 7 L/min	1
	K50	93-07		001149 (9004201-6200)	O-ring	1
	K51	93-07		085043 (9004201-3700)	O-ring	2
F0	QK10	93-07		8510259	Cartridge CPRV kit, 16 bar, 11 L/min	1
	K50	93-07		001149 (9004201-6200)	O-ring	1
	K51	93-07		085043 (9004201-3700)	O-ring	2
F3	QK10	93-07		8510262	Cartridge CPRV kit, 16 bar, 16 L/min	1
	K50	93-07		001149 (9004201-6200)	O-ring	1
	K51	93-07		085043 (9004201-3700)	O-ring	2
N4	QK10	93-07		8510255	Cartridge CPRV kit, 13 bar, 4 L/min	1
	K50	93-07		001149 (9004201-6200)	O-ring	1
	K51	93-07		085043 (9004201-3700)	O-ring	2
N6	QK10	93-07		11097072	Cartridge CPRV kit, 13 bar, 7 L/min	1
	K50	93-07		001149 (9004201-6200)	O-ring	1
	K51	93-07		085043 (9004201-3700)	O-ring	2

Shaft

C9	L100	98-17		8100739	Shaft, 21 tooth spline, 16/32	1
S1	L100	93-07		11014252	Shaft, 14 tooth spline, 12/24	1



Variable displacement motor

(NA, NB, NC, ND & NF)

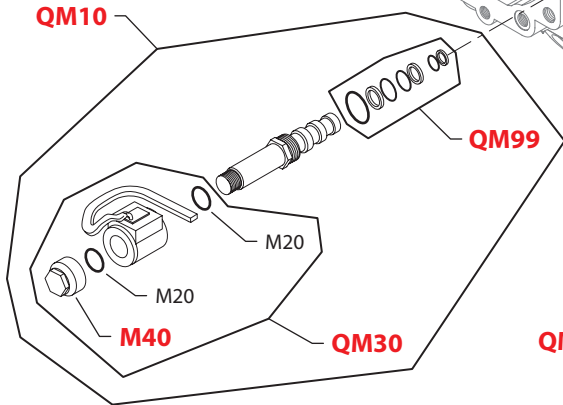

Generic housing used to show part location only

(JB)

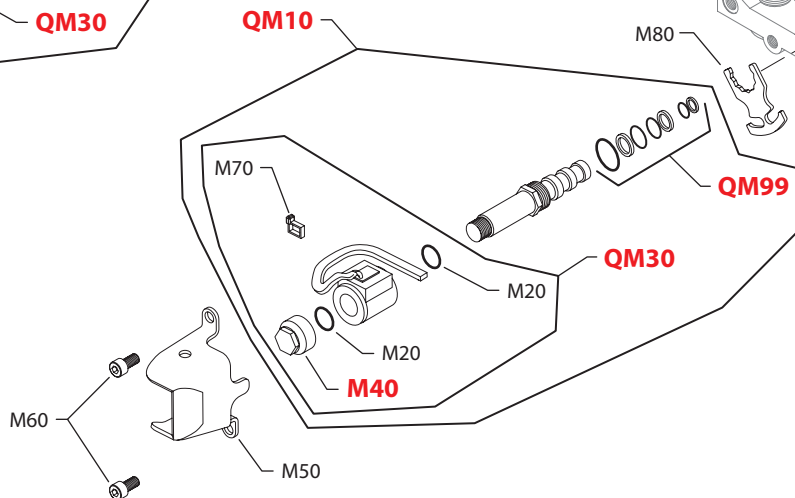

(PT & PX)

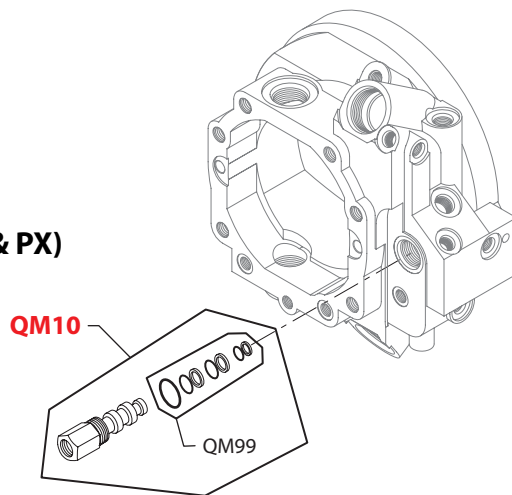

Generic housing used to show part location only

* = included in overhaul seal kit Q210

E100 831E

Enlarged **bold** type item numbers are recommended part to stock for servicing.

Variable displacement motor
Control

Order Code	Item	Date Begin	Date End	Part Number	Part Name	Qty. per Model/Kit
JB	M20	90-34		5000512	O-ring	2
	M40	90-34		5000511	Coil nut, special	1
	M50	90-34		8100714	Solenoid cover	1
	M60	90-34		5000514	Screw	2
	M70	90-34		5000509	Cable tie	1
	M80	90-34		8100781	Solenoid locking plate	1
	QM10	90-34		8510205	Solenoid control valve kit, 12V, metri-pack conn.	1
	QM30	90-34		8510207	Coil kit, 12V, metri-pack conn.	1
	QM99	90-34		8700133	Seal kit	1
NA	M20	90-34		5000512	O-ring	2
	M40	90-34		5000511	Coil nut, special	1
	QM10	90-34		8510218	Solenoid control valve kit, (SB-1998-084)	1
	QM30	90-34		1137412	Coil kit, 12V, MS connector	1
	QM99	90-34		8700133	Seal kit	1
NB	M20	90-34		5000512	O-ring	2
	M40	90-34		5000511	Coil nut, special	1
	QM10	90-34		8510216	Solenoid control valve kit, (SB-1998-084)	1
	QM30	90-34		8510212	Coil kit, 12V, Packard connector	1
	QM99	90-34		8700133	Seal kit	1
NC	M20	90-34		5000512	O-ring	2
	M40	90-34		5000511	Coil nut, special	1
	QM10	90-34		8510219	Solenoid control valve kit, (SB-1998-084)	1
	QM30	90-34		8510215	Coil kit, 24V, MS connector	1
	QM99	90-34		8700133	Seal kit	1
ND	M20	90-34		5000512	O-ring	2
	M40	90-34		5000511	Coil nut, special	1
	QM10	90-34		8510217	Solenoid control valve kit, (SB-1998-084)	1
	QM30	90-34		8510213	Coil kit, 24V, Packard connector	1
	QM99	90-34		8700133	Seal kit	1
NF	M20	90-34		5000512	O-ring	2
	M40	90-34		5000511	Coil nut, special	1
	QM10	90-34		11137414	Solenoid control valve kit, 24V, DIN connector	1
	QM30	90-34		11137415	Coil, 24V, DIN connector	1
	QM99	90-34		8700133	Seal kit	1
PT	QM10	90-34		11137416	Control valve	1
	QM99	90-34		8510178	Seal kit	1
PX	QM10	90-34		11137417	Control valve	1
	QM99	90-34		11141761	Seal kit	1



Variable displacement motor

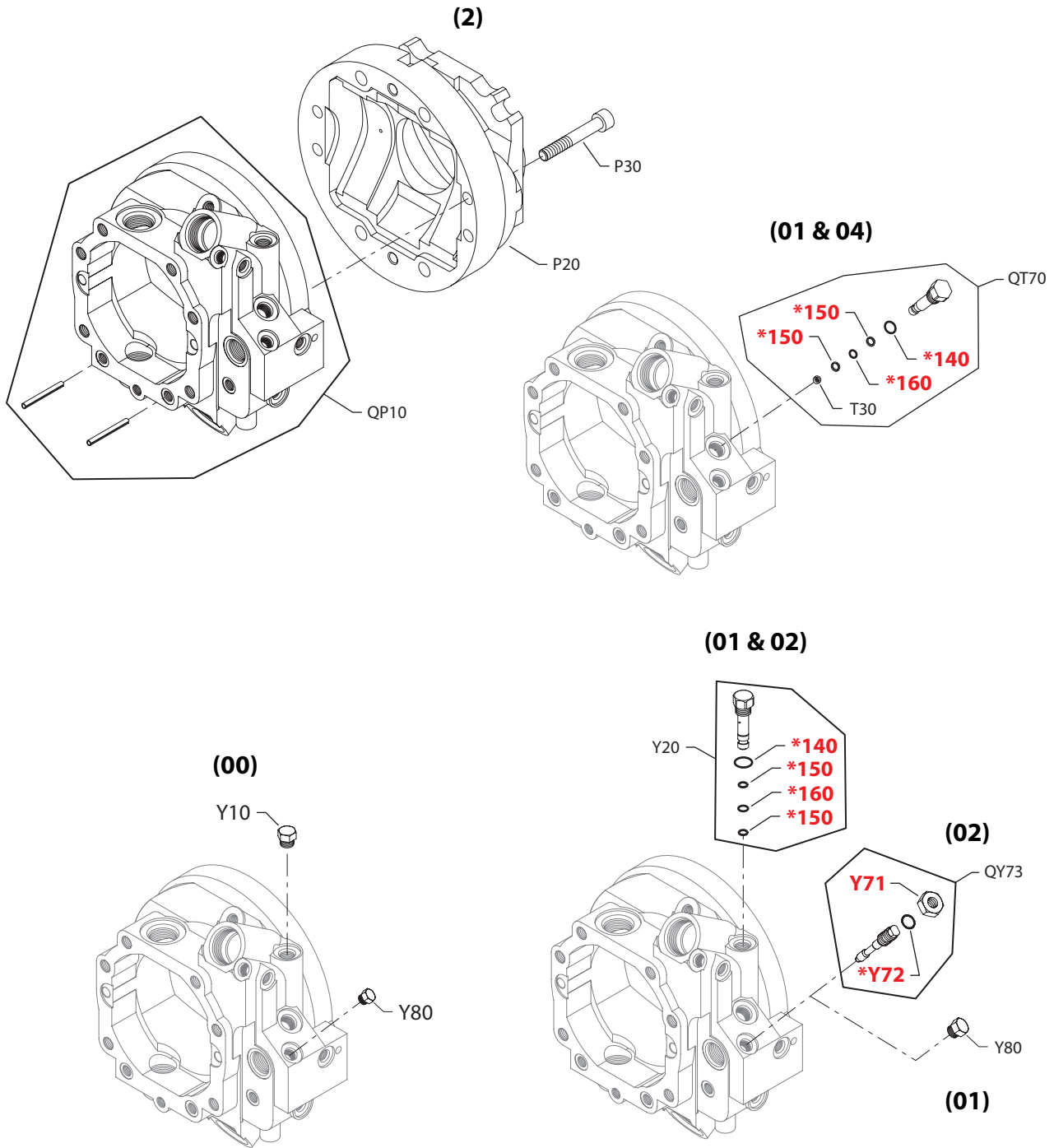

E100 832E

* = included in overhaul seal kit Q210

Enlarged **bold** type item numbers are recommended part to stock for servicing.

Variable displacement motor
Housing

Order Code	Item	Date Begin	Date End	Part Number	Part Name	Qty. per Model/Kit
2	P20	93-07		8100793	Front cover	1
	P30	93-07		9007314-1014	Screw	4
	QP10	93-07		8510059	Housing assembly	1

Servo rate, A

01	QT70	93-07		8510077	Orifice valve assembly, .021	1
	T30	93-07		8800532	Filter screen	1
	140	93-07		085043 (9004201-3700)	O-ring	1
	150	93-07		9006150-0100	Back up ring	2
	160	93-07		732479 (9004105-0100)	O-ring	1
04	T10	93-07		8510228	Orifice valve assembly, .028"	1
	T30	93-07		8800532	Filter screen	1
	140	93-07		085043 (9004201-3700)	O-ring	1
	150	93-07		9006150-0100	Back up ring	2
	160	93-07		732479 (9004105-0100)	O-ring	1

Servo rate, B

00	Y10	93-07		046151 (9005100-5600)	Plug assembly	1
	Y80	93-07		001511 (9005100-4400)	Plug assembly	1
01	Y20	93-07		8510074	Servo orifice assembly, fast	1
	Y80	93-07		001511 (9005100-4400)	Plug assembly	1
	140	93-07		085043 (9004201-3700)	O-ring	1
	150	93-07		9006150-0100	Back up ring	2
	160	93-07		732479 (9004105-0100)	O-ring	1
02	QY73	93-07		8510076	Orifice valve assembly, slow	1
	Y20	93-07		8510075	Orifice valve assembly, slow	1
	Y71	93-07		5000120	Seal nut	1
	Y72	93-07		001123 (9004201-2500)	O-ring	1
	140	93-07		085043 (9004201-3700)	O-ring	1
	150	93-07		9006150-0100	Back up ring	2
	160	93-07		732479 (9004105-0100)	O-ring	1

Variable displacement motor
Overhaul seal kit

Order Code	Item	Date Begin	Date End	Part Number	Part Name	Qty. per Model/Kit
	Q210	93-07		11141344	Overhaul seal kit, 90MV/MVC075	1
	C70	93-07		9007276-0114	Screw	4
	D20	93-07		085043 (9004201-3700)	O-ring	1
	F22	93-07		038281	O-ring	2
	F28	93-07		076042 (9003509-0012)	Seal nut	1
	F49	93-07		8700089	Seal ring	4
	G30	93-07		8100430	End cap gasket	1
	G84	93-07		8800865	Crush ring	2
	K50	93-07		001149 (9004201-6200)	O-ring	1
	K51	93-07		085043 (9004201-3700)	O-ring	1
	L25	93-07		519671	Seal carrier assembly	1
	L85	93-07		8100423	Front cover gasket	1
	L95	93-07		9004104-1710	O-ring	1
	N18	93-07		076042 (9003509-0012)	Seal nut	1
	QB83	93-07		085043 (9004201-3700)	O-ring	1
	QH50	93-07		085043 (9004201-3700)	O-ring	2
	140	93-07		085043 (9004201-3700)	O-ring	2
	150	93-07		9006150-0100	Back up ring	4
	160	93-07		732479 (9004105-0100)	O-ring	2



Order code, variable displacement cartridge motor

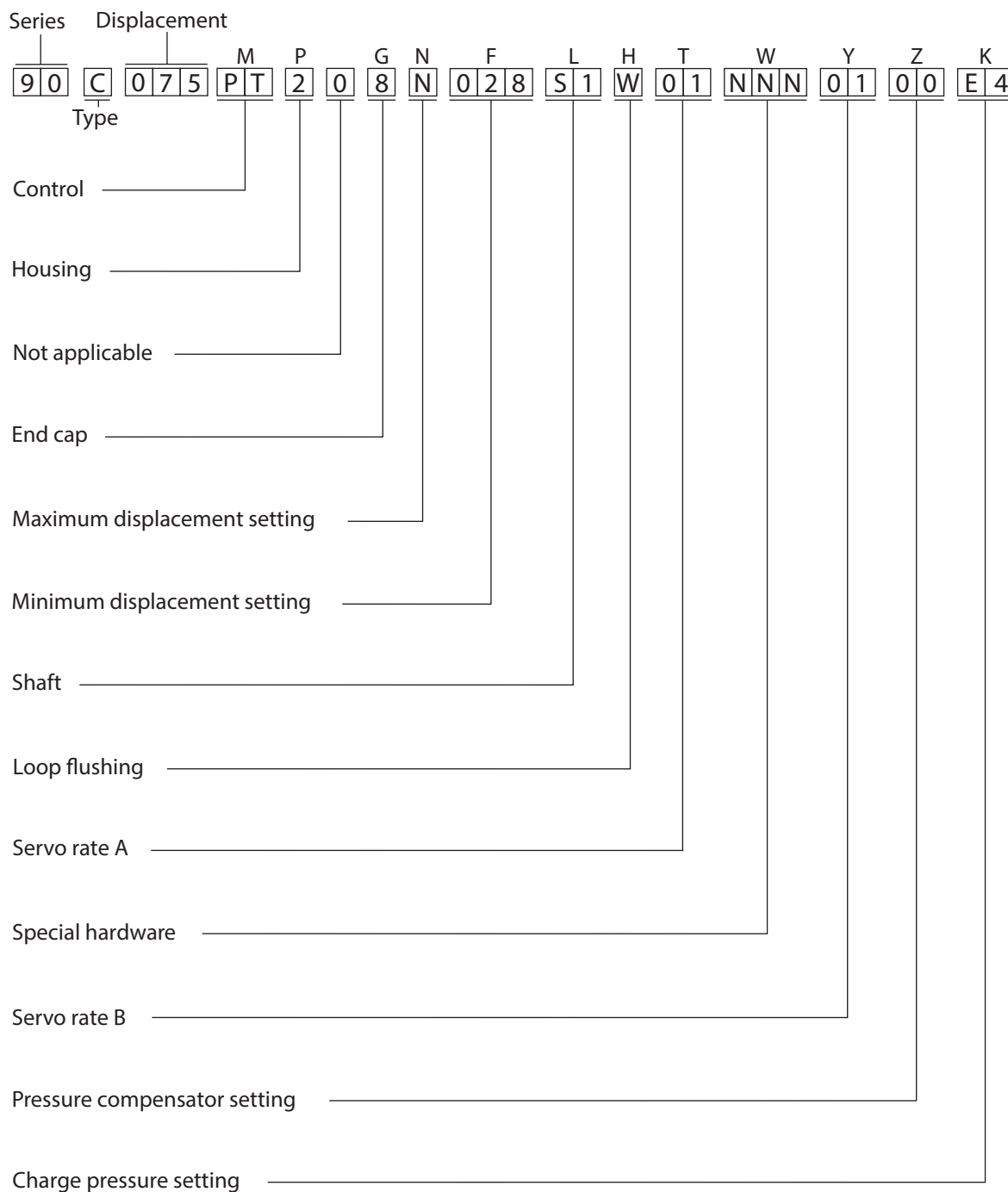

P100 706E



Variable displacement cartridge motor

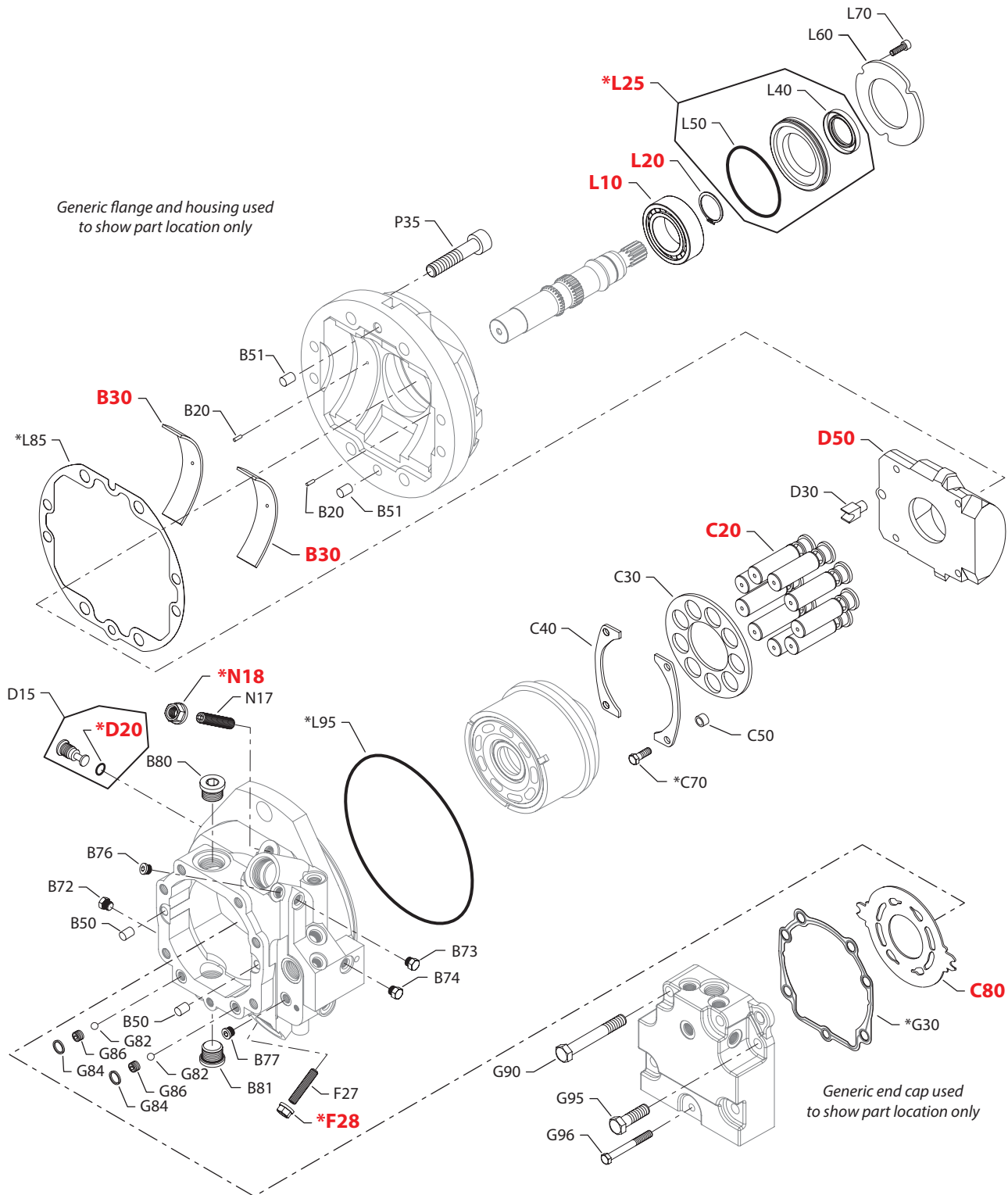

E100 786E

* = included in overhaul seal kit Q210

Enlarged **bold** type item numbers are recommended part to stock for servicing.

Variable displacement cartridge motor
Common parts

Order Code	Item	Date Begin	Date End	Part Number	Part Name	Qty. per Model/Kit
	B20	93-07		5000621	Grooved pin (SB-2000-046)	2
	B30	93-07		8100684	Cradle bearing	2
	B50	93-07		9004800-3708	Pin	2
	B51	93-07		9004800-3708	Pin	2
	B72	93-07		001511 (9005100-4400)	Plug assembly	1
	B73	93-07		001511 (9005100-4400)	Plug assembly	1
	B74	93-07		001511 (9005100-4400)	Plug assembly	1
	B76	93-07		327007 (9005110-4400)	Plug assembly	1
	B77	93-07		327007 (9005110-4400)	Plug assembly	1
	B80	93-07		664524 (9005110-9000)	Plug assembly	1
	B81	93-07		664524 (9005110-9000)	Plug assembly	1
	C20	93-07		708230	Piston assembly (SB-1988-023)	9
	C30	93-07		11067350	Slipper guide	1
	C40	93-07		8100294	Slipper guide bearing	2
	C50	93-07		11065865	Slipper holddown spacer (SB-1998-041)	4
	C65	93-07	98-47	Obsolete	Washer (SB-1998-041)	4
	C70	93-07		9007276-0114	Screw (SB-1998-041)	4
	C80	93-07		323766	Valve plate	1
	D15	93-07		11056875	Hold down pin assembly (SB-1994-024)	1
	D20	93-07		085043 (9004201-3700)	O-ring	1
	D30	93-07		8100406	Hold down arm	1
	D50	93-07		8100928	Swashplate (SB-1998-080)	1
	F27	93-07		330415	Set screw	1
	F28	93-07		9003509-0012	Seal nut	1
	G30	93-07		8100430	End cap gasket	1
	G82	93-07		9001214-2800	Ball	2
	G84	93-07		8800865	Crush ring	2
	G86	93-07		11066594	Orifice plug	2
	G90	93-07		9007210-1216	Screw	4
	G95	93-07		9007210-1209	Screw	2
	G96	93-07		9007210-1016	Screw	1
	L10	93-07		5000505	Roller bearing	1
	L20	93-07		9006300-0156	Retaining ring	1
	L25	93-07		519671	Seal assembly (SB-2006-012)	1
	L40	93-07		519666	Lip seal (SB-2006-012)	1
	L50	93-07		684621 (9004104-1530)	O-ring	1
	L60	93-07		516767	Retainer plate	1
	L70	93-07		041160 (9007314-0605)	Screw	3
	L85	93-07		8100423	Front cover gasket	1
	L95	93-07		9004104-1710	O-ring	1
	N17	93-07		330415	Screw	1
	N18	93-07		9003509-0012	Seal nut	1
	P35	93-07		9007314-1211	Screw	4



Variable displacement cartridge motor

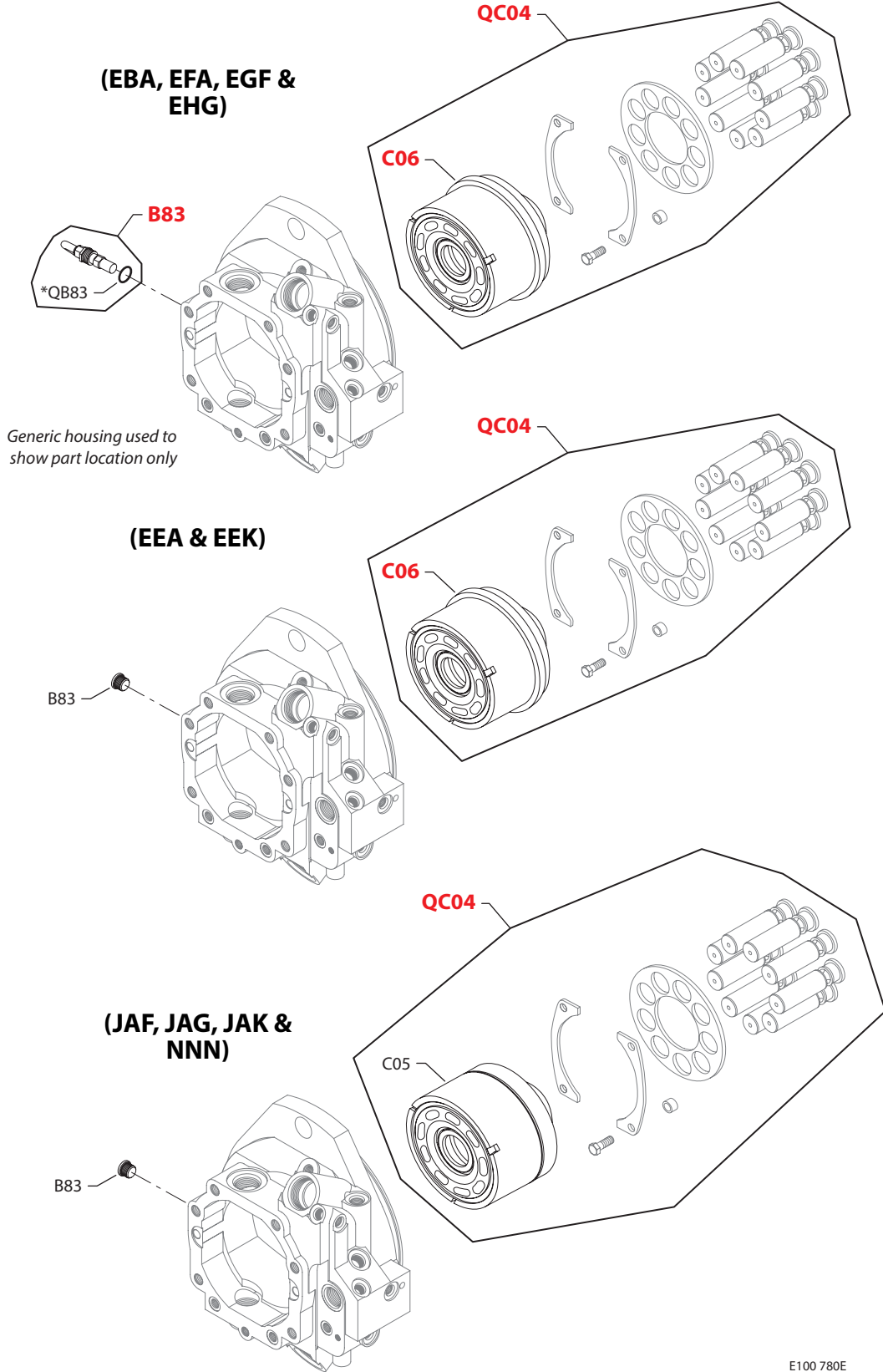

* = included in overhaul seal kit Q210

E100 780E

Enlarged **bold** type item numbers are recommended part to stock for servicing.

Variable displacement cartridge motor
Special hardware

Order Code	Item	Date Begin	Date End	Part Number	Part Name	Qty. per Model/Kit
EBA	B83	90-22		KPPG13408	Speed sensor	1
	C06	90-22		11011714	Cylinder block assy. w/speed ring (SB-2005-018)	1
	QB83	90-22		085043 (9004201-3700)	O-ring	1
	QC04	90-22		8510366	Cylinder block kit, w/speed ring (SB-2005-018)	1
EEA	B83	90-22		140644	Plug assembly	1
	C06	90-22		11011714	Cylinder block assy. w/speed ring (SB-2005-018)	1
	QC04	90-22		8510366	Cylinder block kit, w/speed ring (SB-2005-018)	1
EEK	B83	90-22		140644	Plug assembly	1
	C06	90-22		11011714	Cylinder block assy. w/speed ring (SB-2005-018)	1
	QC04	90-22		8510366	Cylinder block kit, w/speed ring (SB-2005-018)	1
EFA	B83	90-22		KPPG136	Speed sensor	1
	C06	90-22		11011714	Cylinder block assy. w/speed ring (SB-2005-018)	1
	QB83	90-22		085043 (9004201-3700)	O-ring	1
	QC04	90-22		8510366	Cylinder block kit, w/speed ring (SB-2005-018)	1
EGF	B83	90-22		KPPG13703	Speed sensor	1
	C06	90-22		11011714	Cylinder block assy. w/speed ring (SB-2005-018)	1
	QB83	90-22		085043 (9004201-3700)	O-ring	1
	QC04	90-22		8510366	Cylinder block kit, w/speed ring (SB-2005-018)	1
EHG	B83	90-22		KPPG16408	Speed sensor	1
	C06	90-22		11011714	Cylinder block assy. w/speed ring (SB-2005-018)	1
	QB83	90-22		085043 (9004201-3700)	O-ring	1
	QC04	90-22		8510366	Cylinder block kit, w/speed ring (SB-2005-018)	1
JAF	B83	06-12		140644	Plug assembly	1
	C05	06-12		11025822	Cylinder block assembly (SB-2005-018)	1
	QC04	06-12		8510365	Cylinder block kit, w/o speed ring (SB-2005-018)	1
JAG	B83	06-12		140644	Plug assembly	1
	C05	06-12		11025822	Cylinder block assembly (SB-2005-018)	1
	QC04	06-12		8510365	Cylinder block kit, w/o speed ring (SB-2005-018)	1
JAK	B83	06-12		140644	Plug assembly	1
	C05	06-12		11025822	Cylinder block assembly (SB-2005-018)	1
	QC04	06-12		8510365	Cylinder block kit, w/o speed ring (SB-2005-018)	1
NNN	B83	90-22		140644	Plug assembly	1
	C05	90-22		11025822	Cylinder block assembly (SB-2005-018)	1
	QC04	90-22		8510365	Cylinder block kit, w/o speed ring (SB-2005-018)	1



Variable displacement cartridge motor

(026-054)

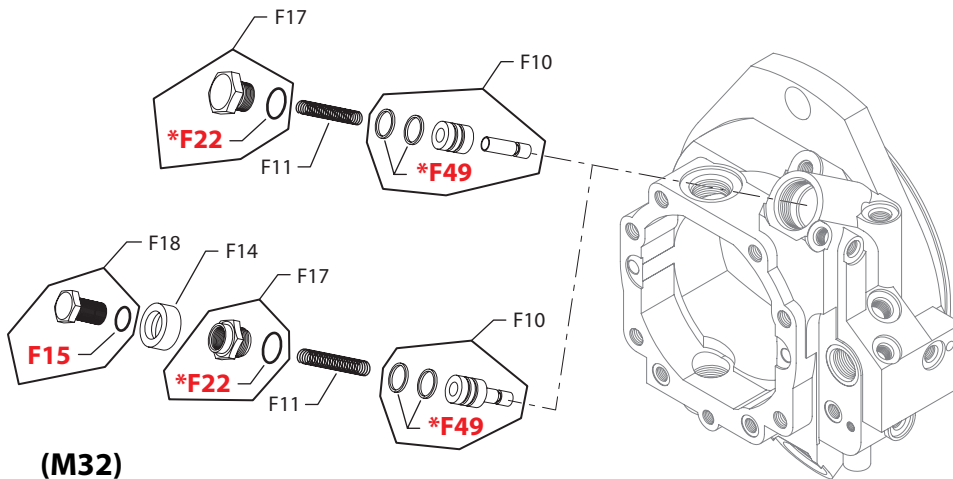

(M32)

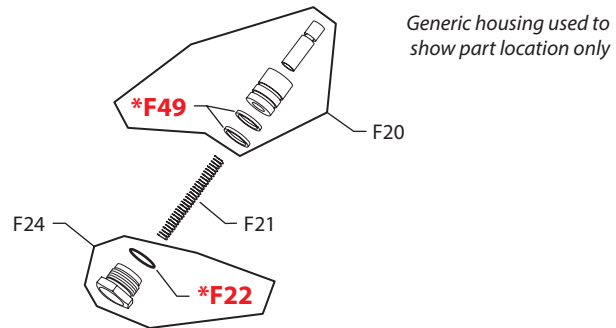

Generic housing used to show part location only

E100 833E

* = included in overhaul seal kit Q210

Enlarged **bold** type item numbers are recommended part to stock for servicing.

Variable displacement cartridge motor
Minimum displacement

Order Code	Item	Date Begin	Date End	Part Number	Part Name	Qty. per Model/Kit
026-054	F10	90-22		8100441	Servo piston assembly	1
	F11	90-22		8800619	Spring	1
	F17	90-22		11056796	Plug. special assembly	1
	F20	90-22		8100441	Servo piston assembly	1
	F21	90-22		8100435	Spring	1
	F22	90-22		038281	O-ring	2
	F24	90-22		11056796	Plug. special assembly	1
	F49	90-22		8700089	Piston seal ring	4
	M32	F10	90-22	13-26	8801165	Servo piston assembly
F11		90-22	13-26	8801161	Spring	1
F14		90-22	13-26	8801214	Servo shield	1
F15		90-22	13-26	012559 (9004202-6200)	O-ring	1
F17		90-22	13-26	11056797	Fitting assembly	1
F18		90-22	13-26	11056777	Servo plug assembly	1
F20		90-22	13-26	8801165	Servo piston assembly	1
F21		90-22	13-26	8801160	Spring	1
F22		90-22	13-26	038281	O-ring	2
F24		90-22	13-26	11056783	Plug. special	1
F49		90-22	13-26	8700089	Piston seal ring	4



Variable displacement cartridge motor

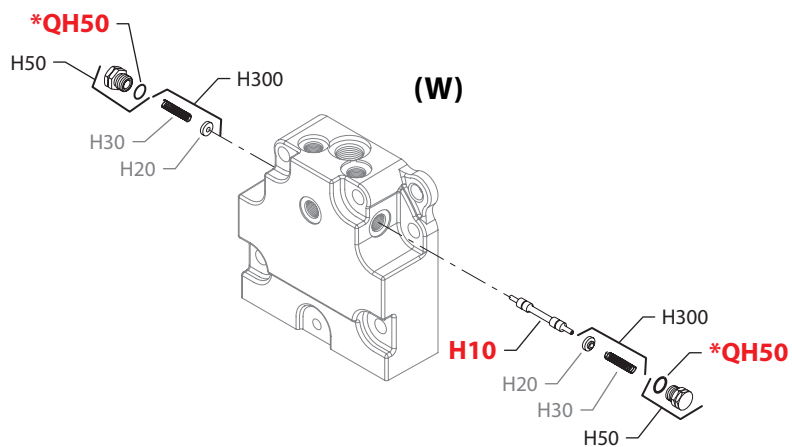
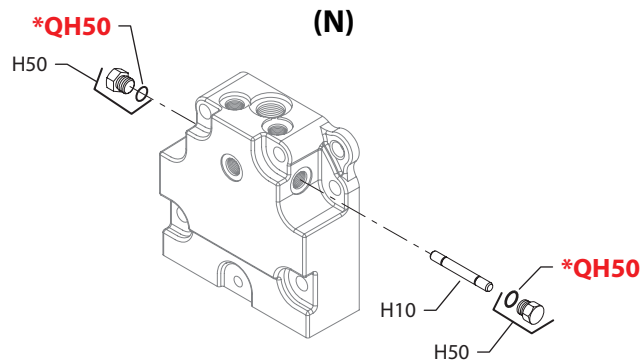
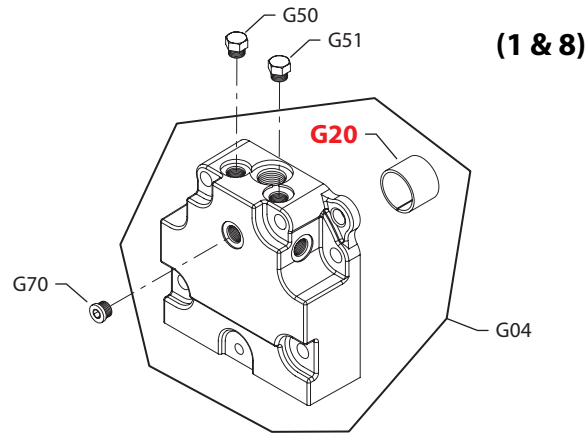

* = included in overhaul seal kit Q210

E100 829E

Enlarged **bold** type item numbers are recommended part to stock for servicing.

Variable displacement cartridge motor
End cap

Order Code	Item	Date Begin	Date End	Part Number	Part Name	Qty. per Model/Kit
1	G04	90-22		8100737	End cap assembly, twin ports	1
	G20	90-22		8700013	Journal bearing	1
	G50	90-22		046151 (9005100-5600)	Plug assembly	1
	G51	90-22		046151 (9005100-5600)	Plug assembly	1
	G70	90-22		140644	Plug assembly	1
8	G04	90-22		8100737	End cap assembly, twin ports	1
	G20	90-22		8700013	Journal bearing	1
	G50	90-22		046151 (9005100-5600)	Plug assembly	1
	G51	90-22		046151 (9005100-5600)	Plug assembly	1
	G70	90-22		140644	Plug assembly	1

Loop flushing

N	H10	90-22		8800668	Loop flushing spool, defeated	1
	H50	90-22		046151 (9005100-5600)	Plug assembly	2
	QH50	90-22		085043 (9004201-3700)	O-ring	2
W	H10	90-22		8800550	Shuttle spool	1
	H50	90-22		518016	Plug assembly	2
	H300	90-22		513596	Spring guide assembly (SB-2000-047)	2
	QH50	90-22		085043 (9004201-3700)	O-ring	2



Variable displacement cartridge motor

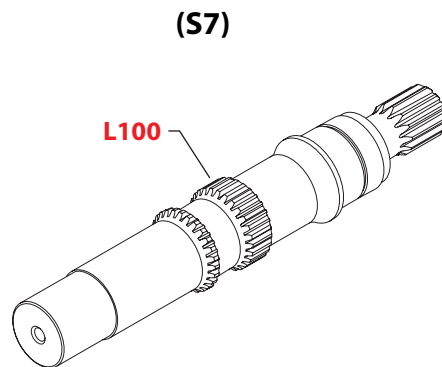
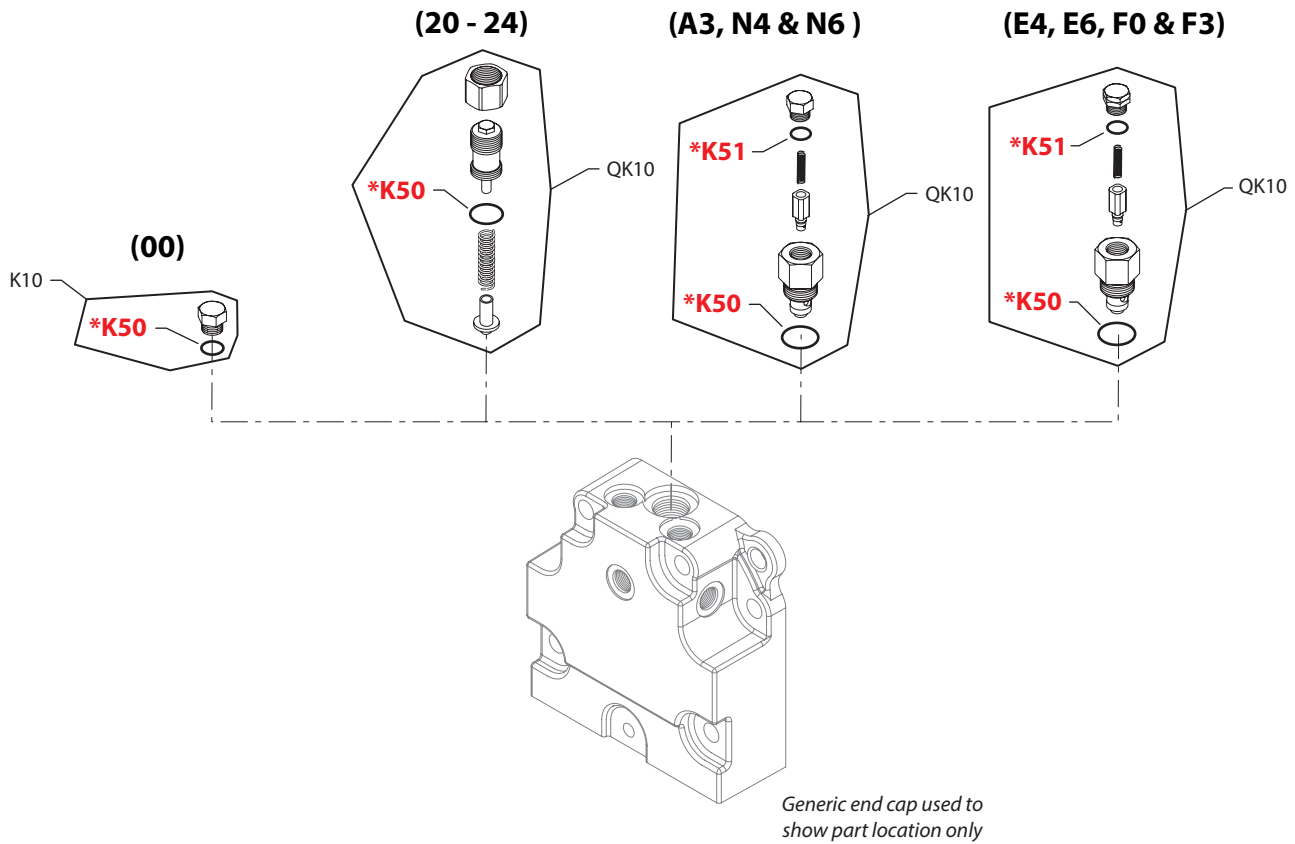

* = included in overhaul seal kit Q210

E100 830E

Enlarged **bold** type item numbers are recommended part to stock for servicing.

Variable displacement cartridge motor
Charge pressure setting

Order Code	Item	Date Begin	Date End	Part Number	Part Name	Qty. per Model/Kit
00	K10	90-22		001537 (9005100-8700)	Plug assembly	1
	K50	90-22		001149 (9004201-6200)	O-ring	1
20-24	QK10	90-22		8510012	Adjustable charge relief valve kit	1
	K50	90-22		001149 (9004201-6200)	O-ring	1
A3	QK10	90-22		8510256	Cartridge CPRV kit, 13 bar, 16 L/min	1
	K50	90-22		001149 (9004201-6200)	O-ring	1
	K51	90-22		085043 (9004201-3700)	O-ring	2
E4	QK10	90-22		8510261	Cartridge CPRV kit, 16 bar, 4 L/min	1
	K50	90-22		001149 (9004201-6200)	O-ring	1
	K51	90-22		085043 (9004201-3700)	O-ring	2
E6	QK10	90-22		8510252	Cartridge CPRV kit, 16 bar, 7 L/min	1
	K50	90-22		001149 (9004201-6200)	O-ring	1
	K51	90-22		085043 (9004201-3700)	O-ring	2
F0	QK10	90-22		8510259	Cartridge CPRV kit, 16 bar, 11 L/min	1
	K50	90-22		001149 (9004201-6200)	O-ring	1
	K51	90-22		085043 (9004201-3700)	O-ring	2
F3	QK10	90-22		8510262	Cartridge CPRV kit, 16 bar, 16 L/min	1
	K50	90-22		001149 (9004201-6200)	O-ring	1
	K51	90-22		085043 (9004201-3700)	O-ring	2
N4	QK10	90-22		8510255	Cartridge CPRV kit, 13 bar, 4 L/min	1
	K50	90-22		001149 (9004201-6200)	O-ring	1
	K51	90-22		085043 (9004201-3700)	O-ring	2
N6	QK10	90-22		11097072	Cartridge CPRV kit, 13 bar, 7 L/min	1
	K50	90-22		001149 (9004201-6200)	O-ring	1
	K51	90-22		085043 (9004201-3700)	O-ring	2

Shaft

S7	L100	90-22		11014254	Shaft, 14 tooth spline, 12/24	1
----	------	-------	--	----------	-------------------------------	---



Variable displacement cartridge motor

(NA, NB, NC, ND & NE)

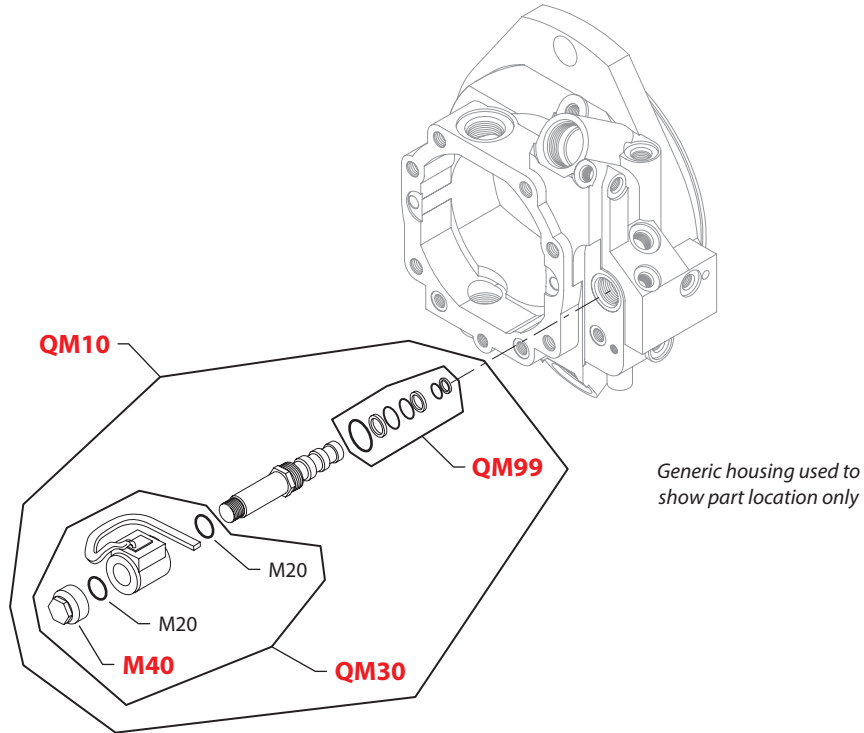

(PT)

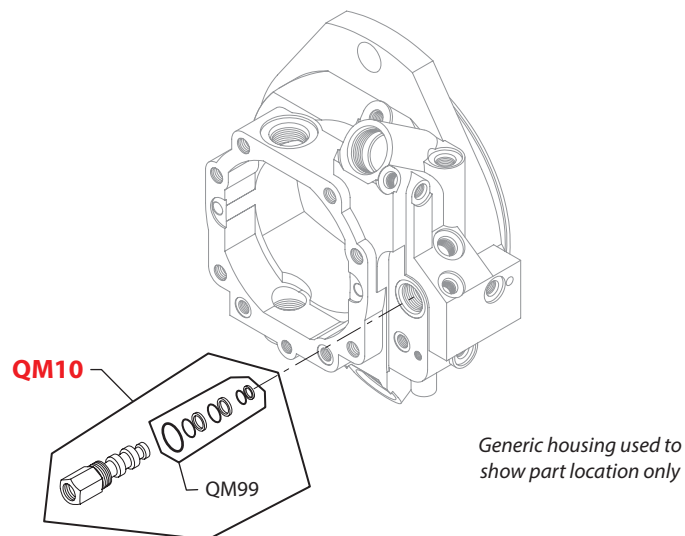

E100 831E

* = included in overhaul seal kit Q210

Enlarged **bold** type item numbers are recommended part to stock for servicing.

Variable displacement cartridge motor
Control

Order Code	Item	Date Begin	Date End	Part Number	Part Name	Qty. per Model/Kit
NA	M20	90-22		5000512	O-ring	2
	M40	90-22		5000511	Coil nut, special	1
	QM10	90-22		8510218	Solenoid control valve kit, (SB-1998-084)	1
	QM30	90-22		11137412	Coil kit, 12V, MS connector	1
	QM99	90-22		8700133	Seal kit	1
NB	M20	90-22		5000512	O-ring	2
	M40	90-22		5000511	Coil nut, special	1
	QM10	90-22		8510216	Solenoid control valve kit, (SB-1998-084)	1
	QM30	90-22		8510212	Coil kit, 12V, Packard connector	1
	QM99	90-22		8700133	Seal kit	1
NC	M20	90-22		5000512	O-ring	2
	M40	90-22		5000511	Coil nut, special	1
	QM10	90-22		8510219	Solenoid control valve kit, (SB-1998-084)	1
	QM30	90-22		8510215	Coil kit, 24V, MS connector	1
	QM99	90-22		8700133	Seal kit	1
ND	M20	90-22		5000512	O-ring	2
	M40	90-22		5000511	Coil nut, special	1
	QM10	90-22		8510217	Solenoid control valve kit, (SB-1998-084)	1
	QM30	90-22		8510213	Coil kit, 24V, Packard connector	1
	QM99	90-22		8700133	Seal kit	1
NE	M20	90-22		5000512	O-ring	2
	M40	90-22		5000511	Coil nut, special	1
	QM10	90-22		8510250	Solenoid control valve kit, (SB-1998-084)	1
	QM30	90-22		11137415	Coil kit, 12V, Packard connector	1
	QM99	90-22		8700133	Seal kit	1
PT	QM10	90-22		11137416	Control valve	1
	QM99	90-22		8510178	Seal kit	1



Variable displacement cartridge motor

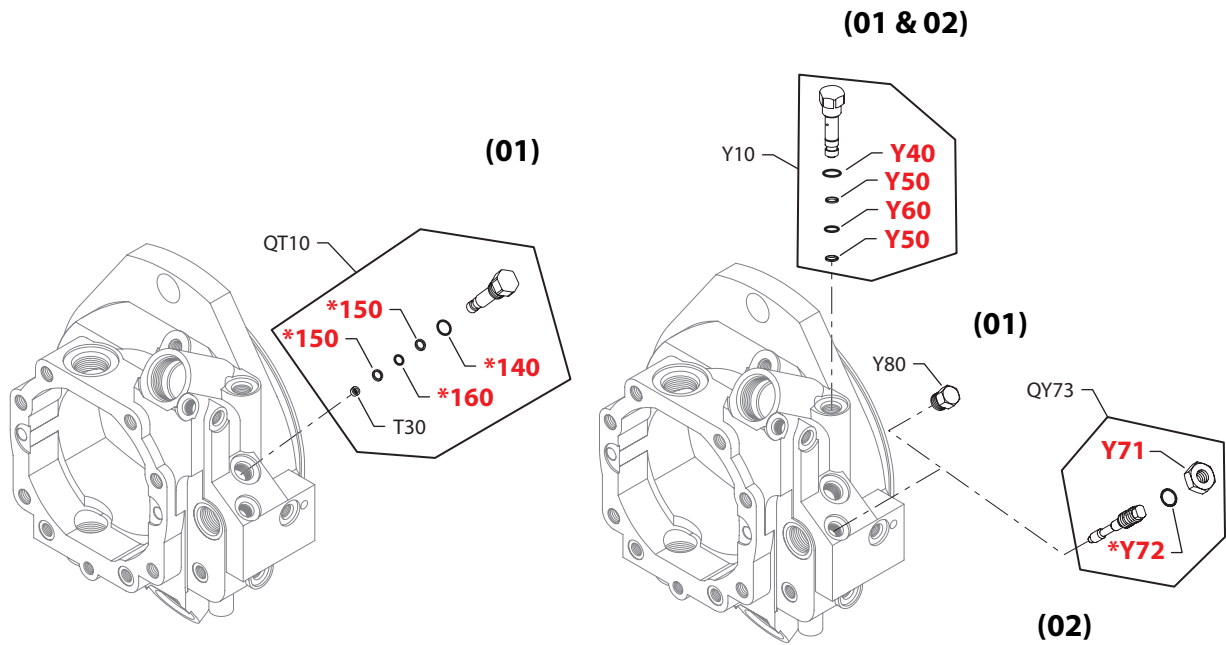
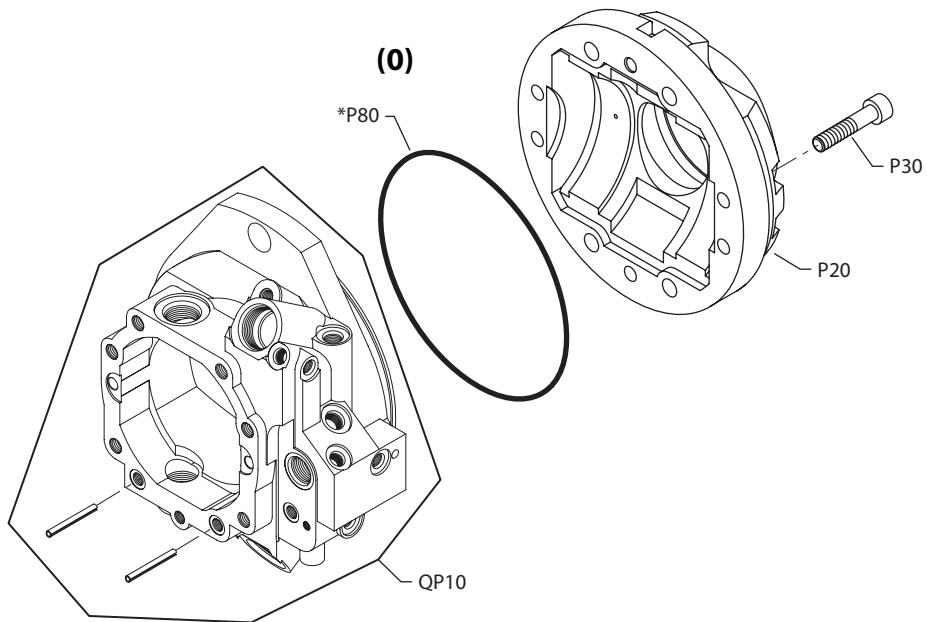

* = included in overhaul seal kit Q210

E100 789E

Enlarged **bold** type item numbers are recommended part to stock for servicing.

Variable displacement cartridge motor
Housing

Order Code	Item	Date Begin	Date End	Part Number	Part Name	Qty. per Model/Kit
0	P20	90-22		8100424	Front cover	1
	P30	90-22		672303 (9007314-1013)	Screw	4
	P80	90-22		9004100-1720	O-ring	1
	QP10	90-22		11139933	Housing assembly	1

Servo rate, A

01	QT70	93-07		8510077	Orifice valve assembly, .021	1
	T30	93-07		8800532	Filter screen	1
	140	93-07		085043 (9004201-3700)	O-ring	1
	150	93-07		9006150-0100	Back up ring	2
	160	93-07		732479 (9004105-0100)	O-ring	1

Servo rate, B

01	Y20	93-07		8510074	Servo orifice assembly, fast	1
	Y80	93-07		001511 (9005100-4400)	Plug assembly	1
	140	93-07		085043 (9004201-3700)	O-ring	1
	150	93-07		9006150-0100	Back up ring	2
	160	93-07		732479 (9004105-0100)	O-ring	1
02	QY73	93-07		8510076	Orifice valve assembly, slow	1
	Y20	93-07		8510075	Orifice valve assembly, slow	1
	Y71	93-07		5000120	Seal nut	1
	Y72	93-07		001123 (9004201-2500)	O-ring	1
	140	93-07		085043 (9004201-3700)	O-ring	1
	150	93-07		9006150-0100	Back up ring	2
	160	93-07		732479 (9004105-0100)	O-ring	1

Variable displacement cartridge motor
Overhaul seal kit

Order Code	Item	Date Begin	Date End	Part Number	Part Name	Qty. per Model/Kit
	Q210	93-07		11141344	Overhaul seal kit, 90MV/MVC075	1
	C70	93-07		9007276-0114	Screw	4
	D20	93-07		085043 (9004201-3700)	O-ring	1
	F22	93-07		038281	O-ring	2
	F28	93-07		076042 (9003509-0012)	Seal nut	1
	F49	93-07		8700089	Seal ring	4
	G30	93-07		8100430	End cap gasket	1
	G84	93-07		8800865	Crush ring	2
	K50	93-07		9004201-6200	O-ring	1
	K51	93-07		9004201-3700	O-ring	1
	L25	93-07		519671	Seal carrier assembly	1
	L85	93-07		8100423	Front cover gasket	1
	L95	93-07		9004104-1710	O-ring	1
	N18	93-07		076042 (9003509-0012)	Seal nut	1
	P80	90-22		9004100-1720	O-ring	1
	QB83	93-07		9004201-3700	O-ring	1
	QH50	93-07		9004201-3700	O-ring	2
	140	93-07		085043 (9004201-3700)	O-ring	2
	150	93-07		9006150-0100	Back up ring	4
	160	93-07		732479 (9004105-0100)	O-ring	2



Service Bulletin: SB-1988-018

Products affected Series 90 fixed motors

Subject Dowel pin change

Description A product change has occurred on Series 90 75 cc and 100 cc fixed displacement motors.

The dowel pins (item G25) have increased in diameter from 1/4" to 3/8". With this change, the dowel pin hole diameters in the end cap (item G047 or G048), housing (item B10), and the valve plate (item C80) have also changed. In addition, the thrust plate (item D50) in the 100 cc fixed displacement motor has also changed to fit the new housing.

This change creates spare parts non-interchangeability among all of the above mentioned parts. All of the affected parts remain available for the repair of any vintage Series 90 fixed motor. Refer to the date code portion of the serial number on the name plate of the motor being repaired when ordering parts.

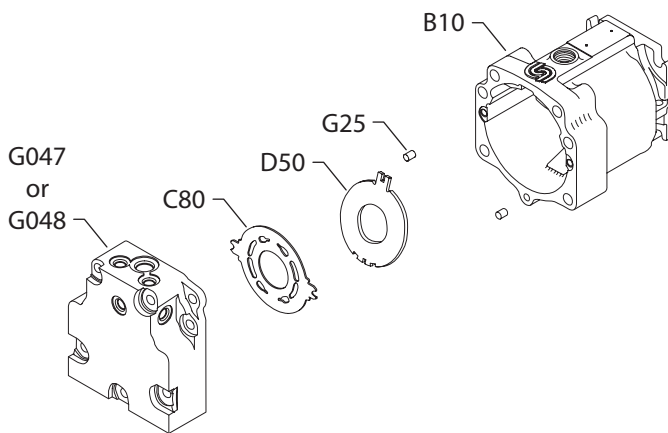

Models affected All 95-3xxx (75 cc) and 96-3xxx (100cc) series 90 fixed displacement motors

Serial numbers Series 90 75 cc fixed motors, 95-3xxx, changed at serial number A-88-43-xxxxx.
Series 90 100 cc fixed motors, 96-3xxx, changed at serial number A-88-23-xxxxx.

Part numbers affected

Item*	Qty/ Motor	75 cc	75 cc	100 cc	100 cc
		Prior to 88-43	From 88-43	Prior to 88-23	From 88-23
G047	1	8100233	8100306	8200123	8200152
G048	1	8100232	8100279	8200122	8200151
C80	1	8100095	8100278	8200103	8200134
D50	1	No Change	No Change	8200014	8200167
G25	2	9004800-2512	9004800-3708	9004800-3116	9004800-3708
B10	1	8100252	8100465	8200099	333641

Parts disposition ■ Non-interchangeable



Service bulletin: SB-1988-023

Products affected

Series 90 pumps and motors

Subject

Piston improvement

Description

Product Information Bulletin PIB-8801 (March, 1988) announced the incorporation of fabricated (welded) piston assemblies, replacing non-fabricated (hollow) piston assemblies, in the cylinder blocks of all Series 90 pumps and motors. This change increases the overall efficiency of the Series 90 product line.

To simplify service parts inventory for all Series 90 units, only individual welded piston assemblies will be available as spare parts. The hollow pistons will be obsolete. Part numbers for individual welded piston assemblies are listed in this bulletin.

Since all Series 90 pumps and motors have nine (9) pistons, welded pistons being used to replace hollow pistons during repair **MUST** be install in the cylinder block symmetrically, in multiples of three (3).

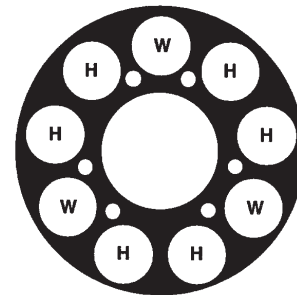
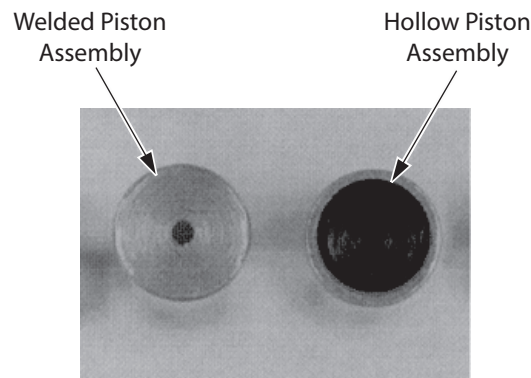

When replacing hollow pistons with welded pistons, it is mandatory that the welded pistons be incorporated symmetrically in multiples of three.

Models affected

All series 90 pumps and motors: 93-xxxx, 94-xxxx, 95-xxxx, and 96-xxxx pumps

Serial numbers

Welded pistons will be incorporated into all series 90 pumps and motors by the end of the first quarter of 1998.

Part numbers affected

Part number	Description
706101	Piston assembly, welded - 42 cc
367672	Piston assembly, welded - 55 cc
708230	Piston assembly, welded - 75 cc
364000	Piston assembly, welded - 100 cc

Parts disposition

■ Interchangeable



Service bulletin: SB-1989-020

Products affected Series 90 fixed displacement motors

Subject Incorporation of adjustable charge relief valve

Description As a product improvement, Sauer-Danfoss is incorporating an externally adjustable charge relief valve on all series 90 fixed displacement motors. This design replaces the previous shimmed relief valve. The new design valve provides a range of pressure adjustment from 10 to 32 bar.

The diameter of the loop flushing shuttle spool increases from .25" (6.35mm) to .375" (9.53mm) at the same incorporation date as the charge relief valve change.

This is a non-interchangeable change. Adjustable style charge relief valves can not be added to motors manufactured before this incorporation date. Old style end caps, which house the charge relief and loop flushing valves, will not be available as service parts. If new end caps are required, new style charge relief and loop flushing parts must also be installed.

Charge relief valve adjustment procedures can be found in the Series 90 Service Manual (BLN-9947 Rev. B). Charge pressure increases/decreases at the rate of 78 psi (5.4 bar) per turn clockwise/counterclockwise.

The new style charge relief plug protrudes from the motor end cap approximately .63" (16mm) farther than the shimmed design. New dimensions from the center line to the top of the charge relief valve plug are shown below.

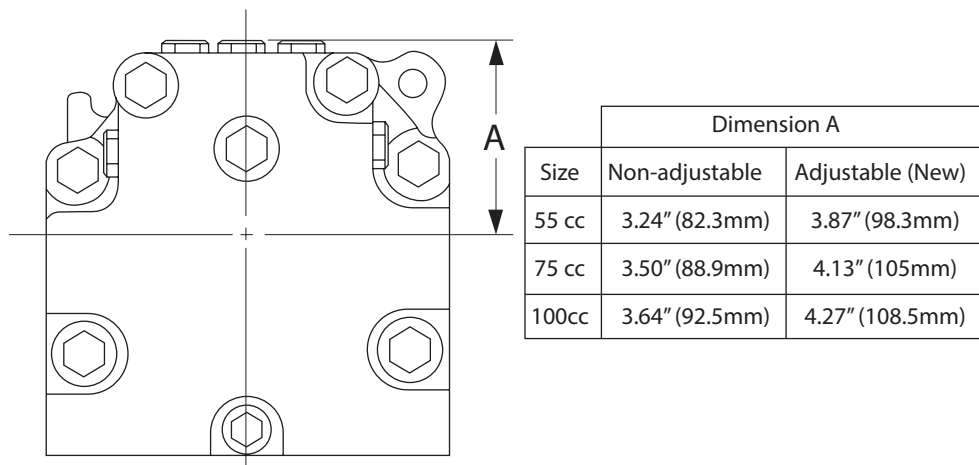



Service bulletin: SB-1989-020

Models affected All 94-3xxx, 95-3xxx, and 96-3xxx fixed displacement motors

Serial numbers affected All 55 cc motors (94-3xxx) will change at s/n A-89-38-xxxxx
 All 75 cc motors (95-3xxx) will change at s/n A-89-44-xxxxx
 All 100 cc motors (96-3xxx) will change at s/n A-90-20-xxxxx

Part numbers affected Charge relief and loop flushing hardware for old vintage motors can be found in the Series 90 Service Parts Manual (520L0890). The new part numbers are as follows:

New charge relief and loop flushing hardware

Item	Part number	Description	Qty
K90	9003575-0101	Nut	1
K10	8800488-1000	Plug assembly	1
K50	9004201-6200	O-ring	1
K70	8800476	Spring	1
K80	8800449	Poppet	1
K000	9005100-8700	Plug assembly	1
H10W	8800550	Shuttle valve spool	1
H20W	8800551	Washer	2
H30W	364950	Spring	2
H40W	9004201-3700	O-ring	2
H50W	9005475-0097	Plug assembly	2
H10N	8800552	Loop flushing spool, defeated	1

New end caps

Part number	Description
8000196	Twin port - 55 cc
8000197	Axial port - 55 cc
8100373	Twin port - 75 cc
8100374	Axial port - 75 cc
8200188	Twin port - 100 cc
8200189	Axial port - 100 cc

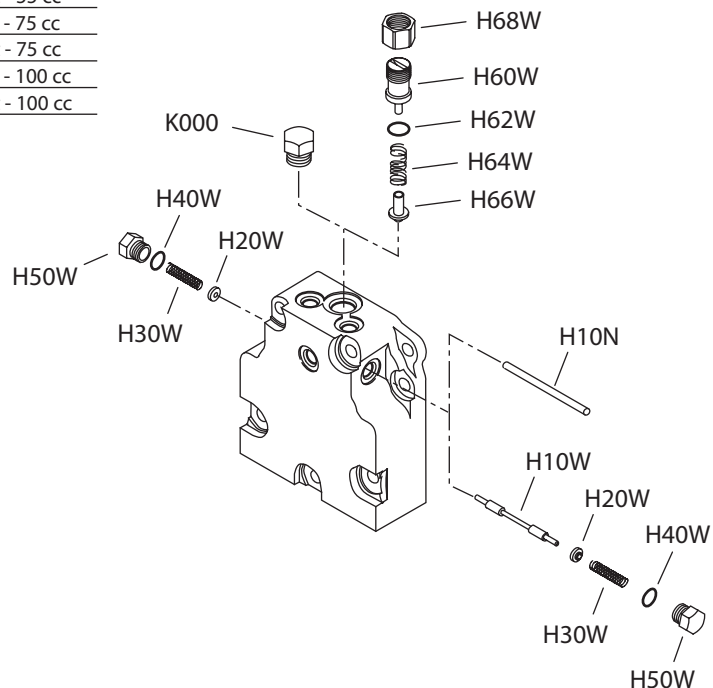

Parts disposition ■ Non-interchangeable

Service bulletin: SB-1994-024

Products affected Series 90 55 and 75 cc variable motors

Subject Swashplate hold down pin

Description As a product improvement, Sauer-Danfoss is changing the design of the swashplate hold down pin used on 55 and 75 cc variable motors.

The previous design used a 1/4 inch internal socket head drive, whereas the new design incorporates a 10 mm drive hex that is not externally accessible. The part number of the hold down pin does not change and is totally interchangeable with the previous design.

Any unit at first repair should be changed to the style hold down pin. Torque the hold down pin to 27 N·m [20 lbf·ft].

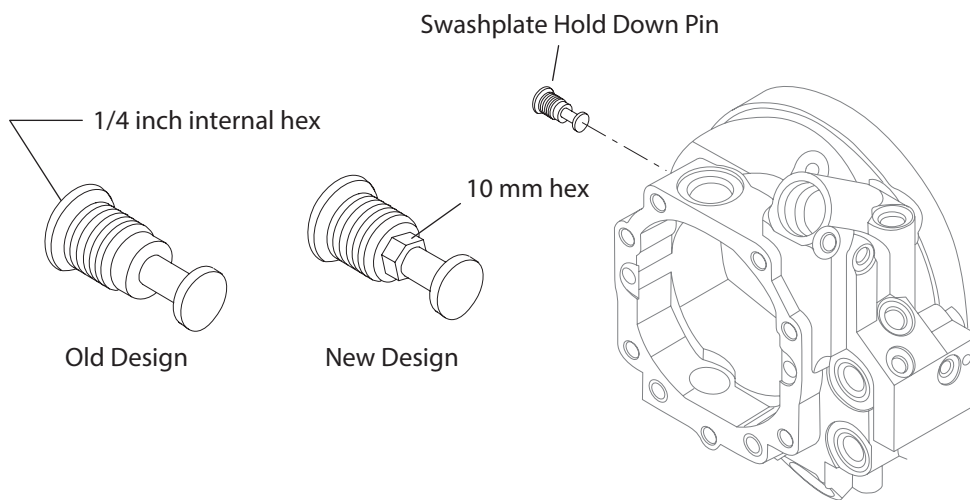

Models affected All 94-4xxx, 944xxxx, 95-4xxx, and 954xxxx variable motors

Serial numbers A-94-10-xxxxx and beyond

Part numbers affected 8800758

Parts disposition ■ Interchangeable

Service bulletin: SB-1998-007
Products affected

Series 90 55cc, 75cc, and 100cc fixed displacement motors, and 55cc and 75cc variable displacement motors

Subject

Charge relief seat

Description

Sauer-Danfoss has initiated a change to the end caps used on series 90 55cc, 75cc, and 100cc fixed displacement motors, and the series 90 55cc and 75cc variable displacement motors.

Currently, the end caps used on these motors contain a pressed in insert, which serves as a seat for the charge pressure relief valve assembly. The insert was originally introduced to provide a suitable wear surface for the charge pressure relief valve poppet.

Since the original design, a number of changes to the charge pressure relief valve design have reduced the severity of the wear characteristics between the poppet and relief seat. These changes have now made it possible to remove the insert from the end cap assembly. The design of the motor end cap has been modified in a manner that allows the charge relief poppet to seat directly against the casting machined surface.

The removal of the insert was initially introduced with the series 90 130cc motors in 1995, and with this change a more uniform product family is achieved.

To aid in identifying and tracking this change, Sauer-Danfoss has released new end cap part numbers. The new end cap is directly interchangeable with the previous end cap and with adjustable charge pressure relief valve components. The previous end cap part numbers will no longer be available as service parts. Page 2 of this bulletin provides part number cross-reference information.

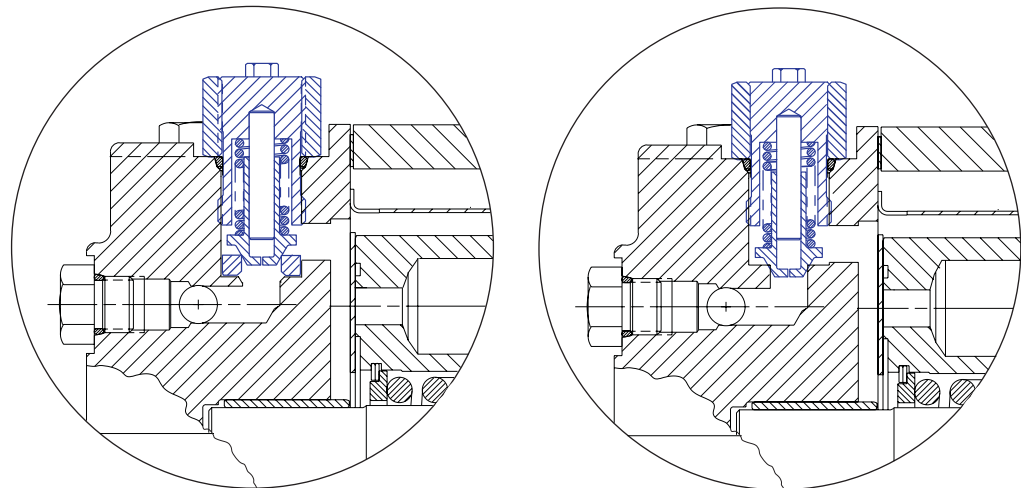

Service bulletin: SB-1998-007
Models affected

All 94-3xxx, 943xxxx, 95-3xxx, 953xxxx, 96-3xxx, and 963xxxx fixed displacement motors
 All 94-4xxx, 944xxxx, 95-4xxx, 954xxxx variable displacement motors

Serial numbers affected

Change became effective with s/n A-98-34-xxxxx and beyond

Part numbers affected

Motor type	Displacement	Order code	Porting	Split flange thread	Prior to 98-34	Current
Fixed	55 cc	D	Twin	Metric	8000417	8000593
Fixed	55 cc	1 & 8	Twin	English	8000196	8000594
Fixed	55 cc	3 & 7	Axial	English	8000197	8000596
Variable	55 cc	R	Twin	Metric	8000356	8000598
Variable	55 cc	1 & 8	Twin	English	8000335	8000599
Fixed	75 cc	D	Twin	Metric	8100576	8100731
Fixed	75 cc	1 & 8	Twin	English	8100373	8100733
Fixed	75 cc	3 & 7	Axial	English	8100374	8100734
Variable	75 cc	1 & 8	Twin	English	8100442	8100737
Fixed	100 cc	E	Twin	English	8200319	8200407
Fixed	100 cc	1 & 8	Twin	English	8200188	8200408
Fixed	100 cc	3 & 7	Axial	English	8200189	8200409

Parts disposition

■ Interchangeable



Service bulletin: SB-1998-041

Products affected

Series 90 55, 75, and 100 cc variable pumps
Series 90 55 and 75 cc variable motors

Subject

Piston hold down mechanism design change

Description

Sauer-Danfoss has initiated a change to the piston hold down mechanism used on series 90 55, 75, and 100 cc variable displacement pump and the series 90 55 and 75 cc variable displacement motors.

Previously, the hold down assembly consisted of a spacer, slipper guide bearing, washer, and screw. The spacer provides a fixed amount of operational clearance for the slipper and slipper retainer. The guide bearing provides a wear surface for the slipper retainer, while the hold down screws and washers retain the assembly.

The change involved with the current design update is the removal of the washer from the assembly. This design was initially introduced on the series 90 42 and 130 cc pumps in 1994, and with this change a uniform product family is achieved.

With the removal of the washer, the required length of the assembly screw is reduced. The change in the assembly screw also affects the dimensions of the spacer. Therefore, with this change, the part numbers associated with the assembly screw and spacer have been changed. Some of the assembly screws are parts already maintained in the parts system.

Although the new spacer and assembly screw are directly interchangeable with the previous swashplate assembly components, we recommend that the components be serviced in combination. Since the new spacer may be serviced as a stand alone item, the previous spacer has been obsoleted and will no longer be available as a service part.

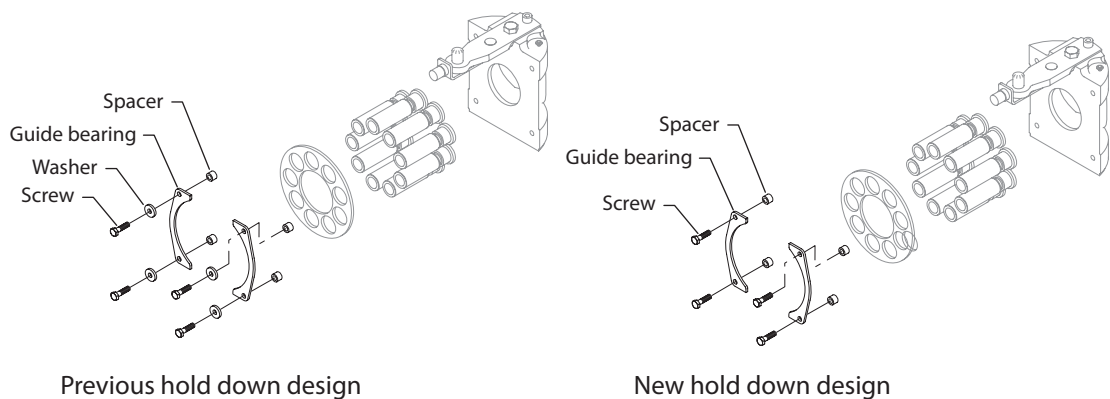



Service bulletin: SB-1998-041

Models affected

94-2xxx, 942xxxx, 95-2xxx, 952xxxx, 96-2xxx, and 962xxxx variable pumps
 94-2xxx, 942xxxx, 95-2xxx, and 952xxxx variable motors

Serial numbers

Sauer-Danfoss Ames production - effective at serial number A-98-48-xxxxx

Part numbers affected

Component	Displacement	Prior to 98-48	Current
Hold down screw	55 cc	9007276-0114	648477
Spacer	55 cc	8000266	8000619
Washer - pumps	55 cc	9009625-0159	N/A
Washer - motors	55 cc	9009625-0129	N/A
Hold down screw	75 cc	9007276-0099	9007276-0114
Spacer	75 cc	8100450	8100777
Washer - pumps	75 cc	9009625-0159	N/A
Washer - motors	75 cc	9009625-0129	N/A
Hold down screw	100 cc	9007276-0099	9007276-0114
Spacer	100 cc	8200216	8200422
Washer - pumps	100 cc	9009625-0159	N/A

Parts disposition

■ Interchangeable



Service bulletin: SB-1998-080

Products affected Series 90 55 and 75 cc variable motors

Subject Motor swashplate change

Description Sauer-Danfoss has initiated a changing to the swashplate used on series 90 55 and 75 cc variable motors.

The process used to develop the required surface hardness of the swashplate has been changed. Due to this change, a slight change in material color may be observed.

In association with this change, Sauer-Danfoss has released new part numbers for the swashplate used in the series 90 55 and 75 cc variable motors. The new swashplate is completely interchangeable with the previous swashplate. The previous swashplate is no longer available as a service part.

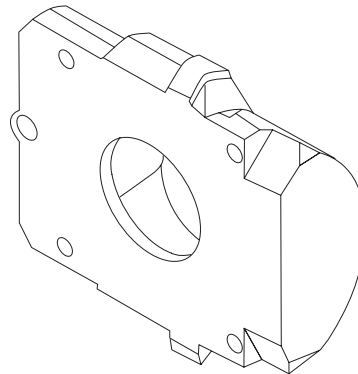

Models affected All 94-4xxxx, 944xxxx, 95-4xxx, and 954xxxx variable displacement motors

Serial numbers This change became effective at serial number A-98-49-xxxxx.

Part numbers affected

Motor size	Old swashplate part number	New swashplate part number
55 cc	8000348	8000618
75 cc	8100431	8100773

Parts disposition ■ Interchangeable



Service bulletin: SB-1998-084

Products affected

Series 90 55 and 75 cc variable motors

Subject

Electronic motor displace control valve change

Description

Sauer-Danfoss has introduced several design and serviceability improvements for the electronic motor shift control valve on series 90 55 and 75 cc variable displacement motors. This change affects motors with NA, NB, NC, and ND style controls.

The electronic solenoid coil has been revised to increase the maximum shift force generated by the coil. The cartridge valve assembly has also been revised to improve the resistance to deflections caused by pressure loading.

The cartridge valve may be installed in the motor housing following the procedures outlined in the series 90 pump and motor service manual. The only differences are that a 1-1/8" hex wrench should be used to install the cartridge valve to a torque level of 47 N·m [35 lbf·ft]. An O-ring is placed on the cartridge valve stem, prior to installing the solenoid coil, and then a second O-ring is placed between the coil and new fastening nut. Torque the fastening nut to 9 N·m [7 lbf·ft], using a 3/4" hex wrench.

In conjunction with these design improvements, Sauer-Danfoss will offer three separate service kits. The first is the control assembly kit (M1), which includes the cartridge valve assembly, the solenoid coil, and associated installation hardware. The second is a coil kit (M3), which includes only the solenoid coil and associated installation hardware. The third is a overhaul seal kit (M2) for the cartridge valve assembly. Assembly instructions are also included in all three kits.

The control assembly kit is completely interchangeable with the previous control kit, which has been obsoleted and no longer available as a service part. The new solenoid coil kit is not compatible with controls in motors produced prior to the incorporation date (A-98-46-xxxxx) and should only be used in servicing motors after that date.

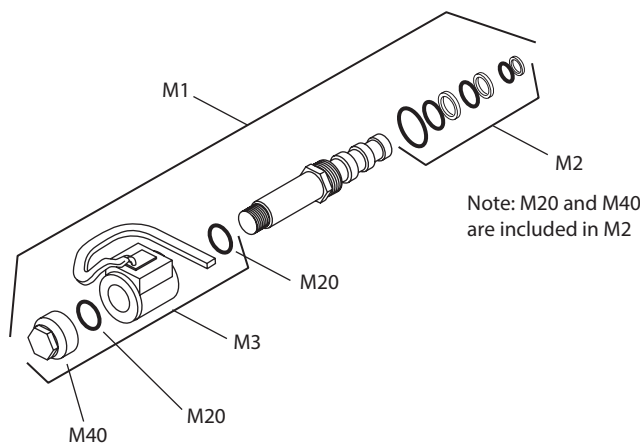

Service bulletin: SB-1998-084
Models affected

All 94-4xxx, 944xxxx, 95-4xxx, and 954xxxx variable displacement motors equipped with electrical displacement control valves.

Serial numbers affected

This change became effective at serial number A-98-46-xxxxx.

Part numbers affected

Cartridge valve overhaul seal kit (M2) is 8510206.

Code	Voltage	Connector	Control assembly kit		Coil kit (M3)
			Previous	Current (M1)	
NA	12V	MS	8700103-0003	8510218	8510214
NB	12V	Packard	8700103-0001	8510516	8510212
NC	24V	MS	8700103-0004	8510219	8510215
ND	24V	Packard	8700103-0002	8510217	8510213

Parts disposition

■ Non-interchangeable



Service bulletin: SB-2000-046

Products affected Series 90 55 and 75 cc variable motors

Subject Swashplate bearing pin change

Description As a product improvement, Sauer-Danfoss has changed the design of the swashplate bearing pin for the series 90 55 and 75 cc variable displacement motors. The old pin was tapered, making it difficult to press into the front cover. It required grease before the swashplate bearings were pressed over them. The new pin is stepped, making it easier to install into the front cover. The swashplate bearings are now a slip fit over the pins, which eliminates the need to grease the pins before the bearings are installed.

This is an interchangeable change. In order to track this change, Sauer-Danfoss has issued a new part number for the pin. The old pin part number is obsolete and no longer available as a service part.

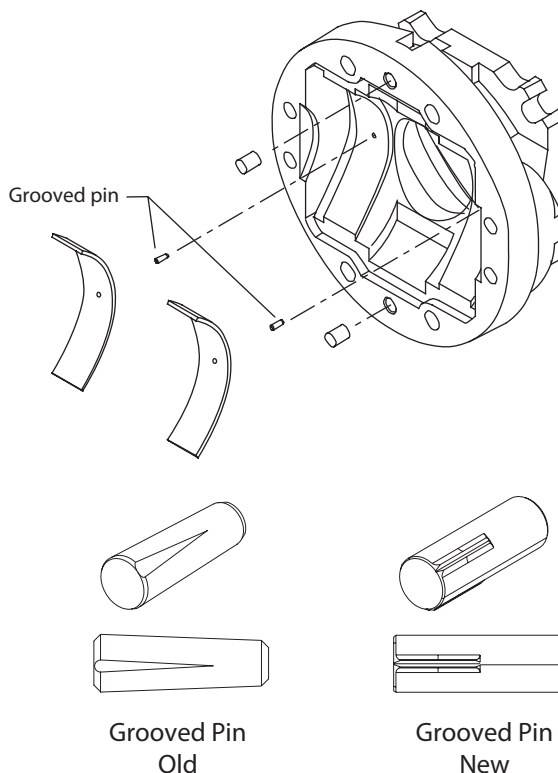

Models affected All 94-4xxx, 944xxxx, 95-4xxx, and 954xxxx variable displacement motors

Serial numbers Change effective at serial number A-01-12-xxxxx.

Part numbers affected

Old pin part number	New pin part number
9004875-0126	5000621

Parts disposition ■ Interchangeable



Service bulletin: SB-2000-047

Products affected

Series 90 42cc, 55cc, 75cc, and 100cc fixed displacement motors, and 55cc and 75cc variable displacement motors

Subject

Loop flushing spring and spring seat change

Description

As a product improvement, Sauer-Danfoss has changed the design of the spring and spring seat for the series 90 42cc, 55cc, 75cc, and 100cc fixed and variable displacement motors. The old design used a separate spring and spring seat. The new design incorporates the two parts into a one piece assembly. This makes the assembly of the spring and spring seat onto the spool much easier than the previous design.

Since the new spring assembly has a high spring rate than the previous spring, this is an interchangeable change only if both springs and spring seats are replaced at the same time. Sauer-Danfoss has issued a new part number for the spring assembly. The previous spring seat and spring remain valid service parts since they are used on other Sauer-Danfoss products.

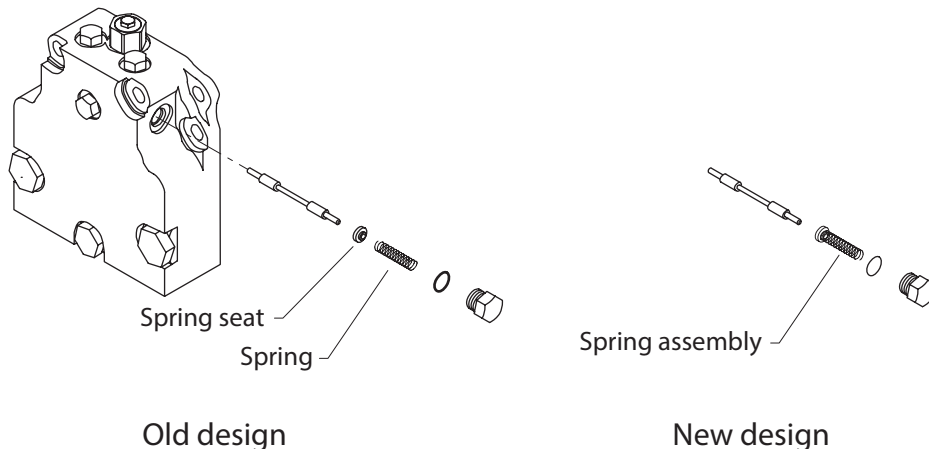

Models affected

All 93-3xxx, 933xxxx, 94-3xxx, 943xxxx, 95-3xxx, 953xxxx, 96-3xxx, and 963xxxx fixed displacement motors with loop flushing options of A, B, or C.

All 94-4xxx, 944xxxx, 95-4xxx, and 954xxxx variable displacement motors with loop flushing options of A, B, or C.

Serial numbers

Sauer-Danfoss Ames, Ia production - Change effective at s/n A-02-03-xxxxx.

Sauer-Danfoss Neumunster, Germany production - Change effective at s/n N-01-08-xxxxx.

Part numbers affected

Previous spring seat	Previous spring	New spring assembly
8800551	4350286	513596

Parts disposition

■ Interchangeable



Service bulletin: SB-2001-011

Products affected Series 90 55cc, 75cc, and 100cc fixed displacement motors

Subject Change to end cap gasket material

Description The end cap gasket material has changed. Sauer-Danfoss has issued new end cap gasket part numbers. The previous part numbers are obsolete. They are no longer available for service.

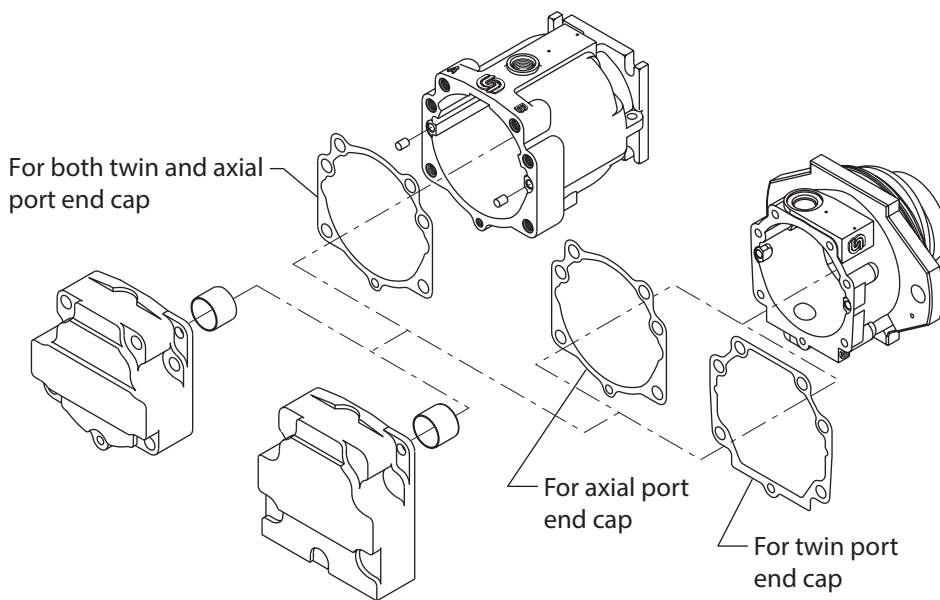

Models affected All 94-3xxx, 943xxxx, 95-3xxx, 953xxxx, 96-3xxx, and 963xxxx fixed displacement motors.

Serial numbers Sauer-Danfoss Ames, la production - Change effective at s/n A-01-19-xxxxx.

Sauer-Danfoss Neumunster, Germany production - Change effective at s/n N-01-19-xxxxx..

Part numbers affected

Frame size	Mounting flange (end cap porting)	Previous end cap gasket	New end cap gasket
55 cc	SAE (all), cartridge (axial)	8000167	8000721
55 cc	Cartridge (twin)	8000603	8000720
75 cc	SAE (all), cartridge (axial)	8100311	8100875
75 cc	Cartridge (twin)	8100749	8100874
100 cc	Sae (all)	8200102	8200511

This change also affects these service kits: 800305030, 81030530, and 82030530

Parts disposition ■ Interchangeable



Service bulletin: SB-2004-015

Products affected Series 90 55cc and 75cc fixed displacement motors

Subject Housing change to accept long screws

Description Sauer-Danfoss has changed the housing used in series 90 55cc and 75cc fixed displacement motors. Material was added at the area of the two shorter end cap mounting screws (G95). The hole for these screws is now deeper to accept the longer screw (G90) that is used for the other four large end cap mounting screws. The six larger screws will have the same stretch and therefore the same clamping force for the gasket sealing area. The small end cap mounting screw (G96) remains the same. The old housing will become obsolete and no longer available for service.

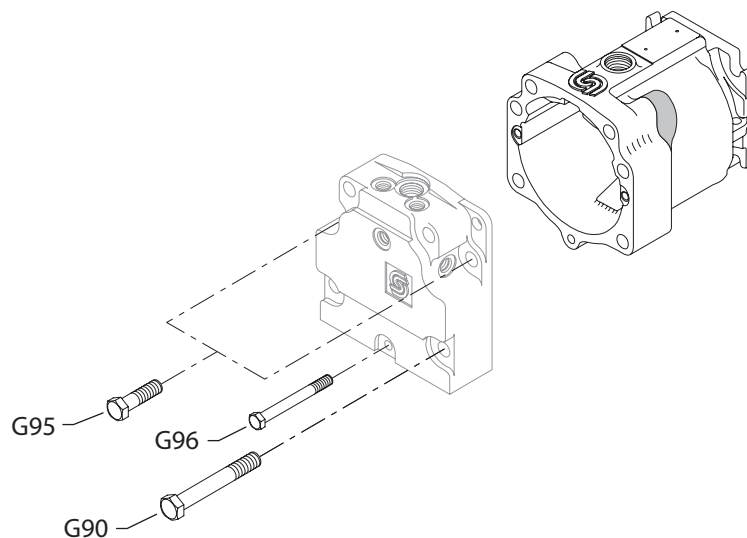

Models affected All 94-3xxx, 943xxxx, 95-3xxx, and 953xxxx fixed displacement motors.

Serial numbers Sauer-Danfoss Ames, Ia production - Change effective on 55 cc at s/n A-05-22-xxxxx. and 75 cc at s/n A-04-51-xxxxx

Sauer-Danfoss Neumunster, Germany production - Change effective on 55 cc at s/n N-04-47-xxxx and 75 cc at s/n N-04-43-xxxxx

Part numbers affected

Description	Old part number	New part number
55 cc housing	8000436	8000782
75 cc housing	8100465	8100965
Screw	9007210-1209	9007210-1216

Parts disposition ■ Non-interchangeable



Service bulletin: SB-2005-018

Products affected Series 90 75 cc fixed and variable displacement motors

Subject Cylinder block change

Description As a product improvement, Sauer-Danfoss has added a special process to the spline area of the cylinder block used in series 90 - 75 cc fixed and variable displacement motors. Three identification grooves will be added to these blocks to indicate this change. All other dimensions of the cylinder block remain the same.

Production built variable pumps will still use the standard cylinder blocks, however cylinder block assembly service kits will contain the "special process" cylinder block, whether they will be used in pumps or motors.

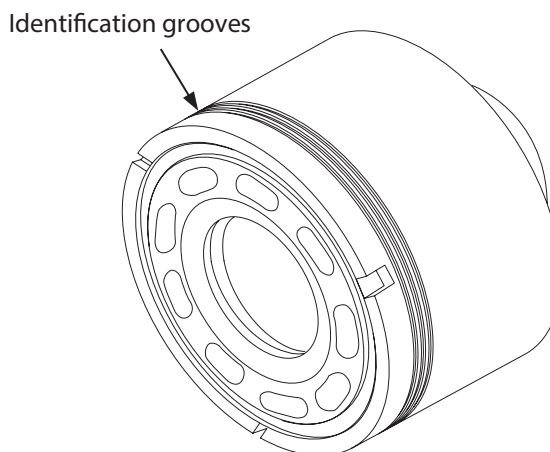

Models affected All Series 90 75 cc fixed and variable displacement motors.

Serial numbers This change became effective at serial number A-06-17-xxxxx.

Part numbers affected	Old p/n	New p/n
	8100798	8100974
	81030507	8510364
	81020507	8510365
	8510237	8510366
	8100804	8100979
	8510236	8510367

Parts disposition ■ Interchangeable



Service bulletin: SB-2006-012

Products affected Series 90 75cc fixed and variable displacement motors

Subject Shaft seal change

Description For commonality of parts, Sauer-Danfoss has changed the lip seal and shaft seal assembly for series 90 75 cc motors.

The new lip seal and shaft seal assembly are interchangeable with the old parts. The shaft seal assembly is obsolete and no longer available as a service part..

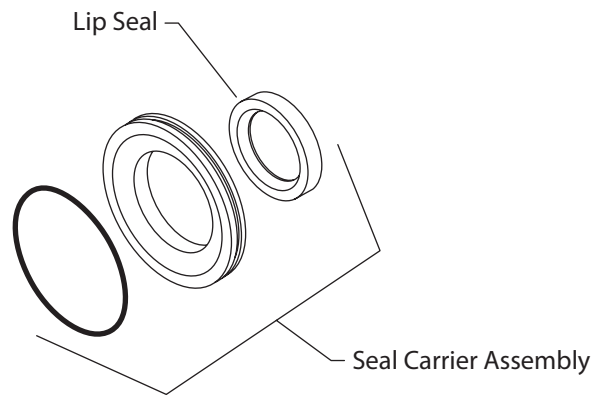

Models affected Series 90 75 cc fixed (MF) and variable (MV) motors.

Serial numbers This change became effective at serial number A-06-18-xxxxx.

Part numbers affected

Description	Old part number	New part number
Lip seal	9008000-0115	519666
Shaft seal assembly	8100553	519671

Parts disposition ■ Interchangeable



Notes



Notes



Notes



Products we offer:

- Bent Axis Motors
- Closed Circuit Axial Piston Pumps and Motors
- Displays
- Electrohydraulic Power Steering
- Electrohydraulics
- Hydraulic Power Steering
- Integrated Systems
- Joysticks and Control Handles
- Microcontrollers and Software
- Open Circuit Axial Piston Pumps
- Orbital Motors
- PLUS+1® GUIDE
- Proportional Valves
- Sensors
- Steering
- Transit Mixer Drives

Danfoss Power Solutions is a global manufacturer and supplier of high-quality hydraulic and electronic components. We specialize in providing state-of-the-art technology and solutions that excel in the harsh operating conditions of the mobile off-highway market. Building on our extensive applications expertise, we work closely with our customers to ensure exceptional performance for a broad range of off-highway vehicles.

We help OEMs around the world speed up system development, reduce costs and bring vehicles to market faster.

Danfoss – Your Strongest Partner in Mobile Hydraulics.

Go to www.powersolutions.danfoss.com for further product information.

Wherever off-highway vehicles are at work, so is Danfoss.

We offer expert worldwide support for our customers, ensuring the best possible solutions for outstanding performance. And with an extensive network of Global Service Partners, we also provide comprehensive global service for all of our components.

Please contact the Danfoss Power Solution representative nearest you.

Comatrol

www.comatrol.com

Schwarzmueller-Inverter

www.schwarzmueller-inverter.com

Turolla

www.turollaocg.com

Valmova

www.valmova.com

Hydro-Gear

www.hydro-gear.com

Daikin-Sauer-Danfoss

www.daikin-sauer-danfoss.com

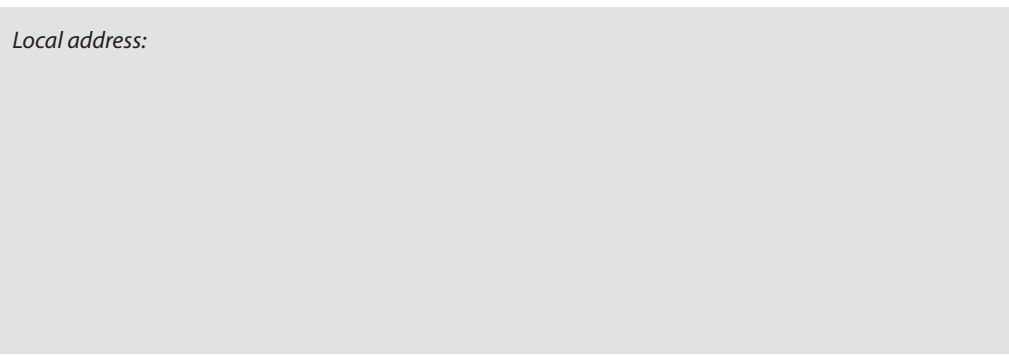

Local address:

Danfoss Power Solutions US Company
2800 East 13th Street
Ames, IA 50010, USA
Phone: +1 515 239 6000

Danfoss Power Solutions GmbH & Co. OHG
Krokamp 35
D-24539 Neumünster, Germany
Phone: +49 4321 871 0

Danfoss Power Solutions ApS
Nordborgvej 81
DK-6430 Nordborg, Denmark
Phone: +45 7488 4444

Danfoss Power Solutions
22F, Block C, Yishan Rd
Shanghai 200233, China
Phone: +86 21 3418 5200

Danfoss can accept no responsibility for possible errors in catalogues, brochures and other printed material. Danfoss reserves the right to alter its products without notice. This also applies to products already on order provided that such alterations can be made without subsequential changes being necessary in specifications already agreed. All trademarks in this material are property of the respective companies. Danfoss and the Danfoss logotype are trademarks of Danfoss A/S. All rights reserved.