

HYDRAULIC GEAR
PUMPS AND
MOTORS

INDEX

Section	Page
INTRODUCTION.....	3
INSTRUCTIONS.....	4
FEATURES.....	5
GEAR PUMPS PERFORMANCE CURVES.....	8
GEAR MOTORS PERFORMANCE CURVES.....	13
SINGLE UNITS DIMENSIONS - SIDE PORTS.....	18
SINGLE UNITS DIMENSIONS - REAR PORTS.....	19
MULTIPLE PUMPS.....	20
MULTIPLE PUMPS DIMENSIONS.....	24
OUTBOARD BEARING OPTIONS.....	26
VERSION WITH OUTBOARD BEARING.....	27
DRIVE SHAFTS.....	31
MOUNTING FLANGES AND TABLE OF COMPATIBILITY.....	34
PORTS POSITION AND TYPE.....	38
VALVE OPTIONS.....	43
HOW TO ORDER - SINGLE UNITS.....	44
HOW TO ORDER - POLARIS PHP 20 DOUBLE PUMPS.....	46
HOW TO ORDER - POLARIS PHP 20 DOUBLE PUMPS DIFFERENT GROUPS.....	48

Replaces: 04/01.2019

05/05.2023



Modification from former edition.

INTRODUCTION

“PH” series gear pumps and motors is an evolution of the “POLARIS” series.

“POLARIS PH” has a new body made of cast iron to have higher operating parameters and keep the full POLARIS versatility regarding shafts, flanges, ports and built-in valves. This project is targeted for forklifts, skid steer loaders and all those applications where traditional aluminum pumps are being pushed close to their limits. The possibility to mate the body with the cast iron covers further reduces noise levels, in addition to increasing strength.

DISPLACEMENTS

From 8.26 cm³/rev (0.50 in³/rev)
To 33,03 cm³/rev (2.01 in³/rev)

PRESSURE

Max. continuous 250 bar (3625 psi)
Max. intermittent 280 bar (4060 psi)
Max. peak 300 bar (4350 psi)

SPEED

Max. 3500 min⁻¹

TYPICAL APPLICATIONS

- Building & Construction
- Material Handling
- Agriculture
- Forestry
- Turf care & Mowers
- Fan Drive

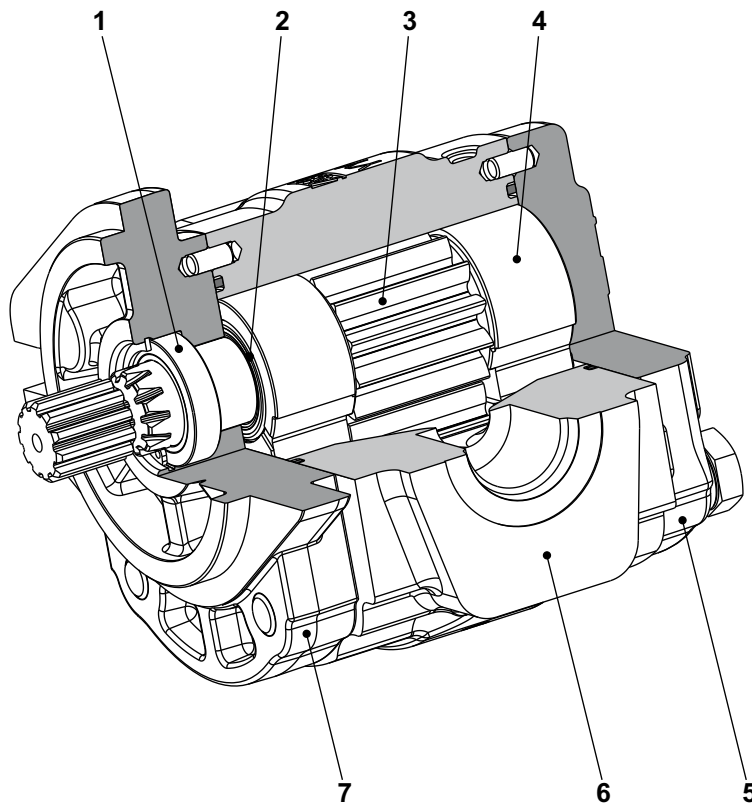

1	Shaft seal
2	Seal
3	Gear
4	Thrust plate
5	Cover
6	Body
7	Mounting flange

04/01.2019

- High working pressure also for high displacements
- Long service life
- Low noise version available
- High volumetric efficiency also at high temperature
- High versatility due to Polaris 20 family components
- Inlet & outlet optimization - High speed
- Combination in multiple pumps
- Built-in valves simplify circuit design

INSTRUCTIONS

INSTALLATION

Pump

The direction of rotation of single-rotation pumps must be the same as that of the drive shaft. Check that the coupling flange correctly aligns the transmission shaft and the pump shaft. Flexible couplings should be used (never rigid fittings) which will not generate an axial or radial load on the pump shaft.

Motor

The direction of rotation of single-rotation motors must match circuit connections. Check that the coupling flange correctly aligns the transmission shaft and the motor shaft. Flexible couplings should be used (never rigid fittings) which will not generate an axial or radial load on the motor shaft.

TANK

Tank capacity must be sufficient for the system's operating conditions (~ 3 times the amount of oil in circulation) to avoid overheating of the fluid. A heat exchanger should be installed if necessary. The intake and return lines in the tank must be spaced apart (by inserting a vertical divider) to prevent the return-line oil from being taken up again immediately.

LINES

The lines must have a major diameter which is at least as large as the diameter of pump or motor ports, and must be perfectly sealed. To reduce loss of power, the lines should be as short as possible, reducing the sources of hydraulic resistance (elbow, throttling, gate valves, etc.) to a minimum. A length of flexible tubing is recommended to reduce the transmission of vibrations. All return lines must end below the minimum oil level, to prevent foaming. Before connecting the lines, remove any plugs and make sure that the lines are perfectly clean.

HYDRAULIC FLUID

Use hydraulic fluid conforming to viscosity data as specified in the first pages of the catalogue.

Avoid using mixtures of different oils which could result in decomposition and reduction of the oil's lubricating power.

FILTERS

We recommend filtering the entire system flow. Filters on suction and return line must be fitted in according to the contamination class as indicated in the first pages of the catalogue. Casappa recommends to use its own production filters:



STORAGE

The storage must be in a dry environment. Max storage time in ideal conditions is 24 months. The ideal storage temperature is between 5 °C (41 °F) and 20 °C (68 °F).

No problem in case of temperature between -40 °C (-40 °F) and 50 °C (122 °F). Below -40 °C (-40 °F) please contact us.

STARTING UP

Check that all circuit connections are tight and that the entire system is completely clean. Insert the oil in the tank, using a filter. Bleed the circuit to assist in filling. Set the pressure relief valves to the lowest possible setting. Turn on the system for a few moments at minimum speed, then bleed the circuit again and check the level of oil in the tank.

If the difference between pump or motor temperature and fluid temperature exceeds 10 °C (18 °F), rapidly switch the system on and off to heat it up gradually. Then gradually increase the pressure and speed of rotation until the preset operating levels as specified in the catalogue are attained.

COLD START

Cold start is meant short term and low idle. During cold start of the machine the following limits can be applied:

Minimum inlet pressure	0,5 bar abs. (7 psi)
Outlet pressure (pumps) Inlet pressure (motors)	≤ 50 bar (725 psi)
Max drain pressure / Max back pressure for single rotation motors	+ 50% of standard values
Speed	≤ 1500 min ⁻¹
Minimum temperature	-40 °C (-40 °F)
Max oil viscosity	2000 mm ² /s (cSt) [9100 SSU]

If the ambient temperature is lower than -20 °C (-4 °F) the system speed and pressure must be limited until the hydraulic oil temperature exceeds -20 °C (-4 °F).

PERIODICAL CHECKS - MAINTENANCE

Keep the outside surface clean especially in the area of the drive shaft seal. In fact, abrasive powder can accelerate wear on the seal and cause leakage. Replace filters regularly to keep the fluid clean. The oil level must be checked and oil replaced periodically depending on the system's operating conditions.

Replaces: 04/01.2019

05/05.2023

FEATURES

Construction	Heavy duty external gear pumps and motors 3-piece construction
Mounting	EUROPEAN - SAE - GERMAN standard flanges
Ports	Threaded or split flange
Direction of rotation (looking at the drive shaft)	Anti-clockwise (S) - clockwise (D) - reversible external drain (R - L) reversible internal drain (B)
Inlet pressure range for pumps	0,7 ÷ 3 bar abs. (10 ÷ 44 psi) If p > 1,5 bar abs. (22 psi) specific shaft sealing have to be applied. Please contact us for more information.
Max back pressure for single rotation motors	5 bar (73 psi) continuous @ min. speed 350 min ⁻¹ 1 bar (14.5 psi) continuous @ max. speed (see page 7)
Max drain line pressure on reversible rotation motors	5 bar (73 psi) continuous @ min. speed 350 min ⁻¹ 1 bar (14.5 psi) continuous @ max. speed (see page 7)
Max back pressure on in series motors	150 bar (2175 psi)
Fluid temperature range	See table (1)
Fluid	Mineral oil based hydraulic fluids to ISO/DIN. Please contact us for other fluids
Viscosity range	From 12 to 100 mm ² /s (cSt) [60 to 456 SSU] recommended Up to 750 mm ² /s (cSt) [3410 SSU] permitted
Filtering requirement and recommended fluid contamination	See table (2) page 6

Tab. 1

Type	Fluid composition	Max pressure bar (psi)	Max speed min ⁻¹	Temperature - °C (°F)			Seals (●)	Shaft seals option (◆)
				Min	Max continuous	Max peak		
ISO/DIN	Mineral oil based hydraulic fluid to ISO/DIN	See page 7	See page 7	-25 (-13)	80 (176)	100 (212)	N	D C1
				-25 (-13)	110 (230)	125 (257)	V	
				-25 (-13)	110 (230)	125 (257)	T-PV	

(●) **N** = Buna NBR (standard) - **V** = Viton-FKM - **T-PV** = Hydrogenated buna HNBR seals with Viton-FKM shaft seals

D (◆) shaft seals with wiper seal

C1 (◆) High pressure special shaft seal

04/01.2019

Single rotation pumps

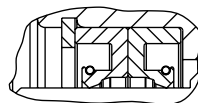
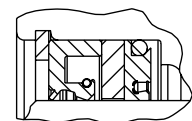
 Max drain
line pressure:
0,5 bar (7 psi)

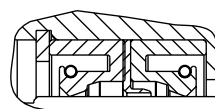
 Max drain
line pressure:
10 bar (145 psi)
@ 350 min⁻¹

 Single rotation motors
Reversible rotation pumps and motors

 Max drain
line pressure:
5 bar (73 psi)
@ 350 min⁻¹

FEATURES

FILTRATION

Tab. 2

Working pressure bar (psi)	$\Delta p < 140$ $\Delta p < (2030)$	$140 < \Delta p < 210$ $(2030) < \Delta p < (3045)$	$\Delta p > 210$ $\Delta p > (3045)$
Contamination class NAS 1638	10	9	8
Contamination class ISO 4406	21/19/16	20/18/15	19/17/14
Achieved with filter $\beta_{10}(c) \geq 200$ ISO 16889	-	10 μm	10 μm
Achieved with filter $\beta_{25}(c) \geq 200$ ISO 16889	25 μm	-	-

Casappa recommends to use its own production filters:



DEFINITION OF ROTATION DIRECTION LOOKING AT THE DRIVE SHAFT

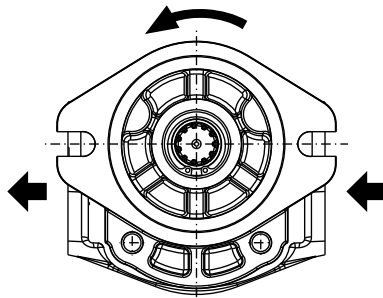

Anti-clockwise rotation

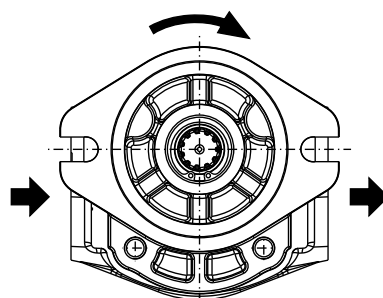

Clockwise rotation

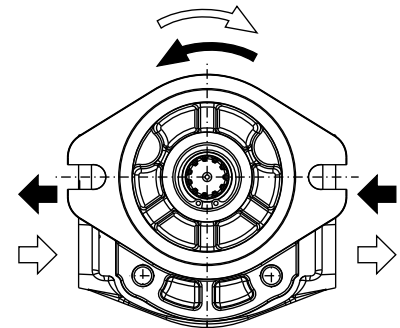

Reversible rotation

PRESSURE DEFINITION

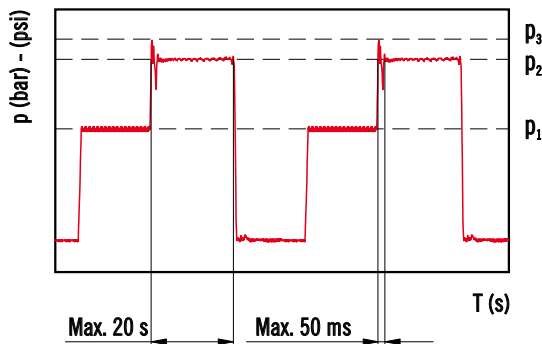

- p_1 Constant operating pressure
- p_2 System pressure (relief valve setting)
- p_3 Peak of pressure

The peak of pressure is the max pressure allowed and it corresponds to the overshoot of the relief valve.

Please note that both relief valve setting and overshoot must be lower than their limits.

If the relief setting is compliant but the overshoot is higher than the limit, the relief setting must be decreased until the overshoot is compliant to Casappa limit.

Please contact us for high frequency applications.

04/01.2019

FEATURES

Replaces: 04/01.2019

Pump type PHP Motor type PHM	Displacement cm ³ /rev (in ³ /rev)	Max. pressure			Max. speed min ⁻¹	Min. speed min ⁻¹
		P ₁	P ₂	P ₃		
		bar (psi)				
PH. 20•8	8,26 (0.50)	250 (3600)	280 (4060)	300 (4350)	3500	500
PH. 20•10,5	10,9 (0.66)	250 (3600)	280 (4060)	300 (4350)	3500	500
PH. 20•11,2	11,23 (0.69)	250 (3600)	280 (4060)	300 (4350)	3500	500
PH. 20•14	14,53 (0.89)	250 (3600)	280 (4060)	300 (4350)	3500	500
PH. 20•16	16,85 (1.03)	250 (3600)	280 (4060)	300 (4350)	3500	500
PH. 20•18	18,29 (1.12)	250 (3600)	280 (4060)	300 (4350)	3500	500
PH. 20•19	19,09 (1.16)	250 (3600)	280 (4060)	300 (4350)	3500	500
PH. 20•20	21,14 (1.29)	250 (3600)	280 (4060)	300 (4350)	3500	500
PH. 20•23	23,32 (1.42)	250 (3600)	280 (4060)	300 (4350)	3000	500
PH. 20•24,5	24,84 (1.52)	230 (3335)	260 (3770)	280 (4060)	3000	500
PH. 20•25	26,42 (1.61)	230 (3335)	260 (3770)	280 (4060)	3000	500
PH. 20•27,8	28,21 (1.72)	200 (2900)	230 (3335)	250 (3625)	2500	500
PH. 20•31,5	33,03 (2.01)	200 (2900)	230 (3335)	250 (3625)	2500	500

Pressure values in the table refer to side ports unidirectional pumps and motors.

For reversible pumps and motors, max pressures are 250 bar (3600 psi) excepted those with lower pressure values.

Please contact us for different configurations and working conditions..

Q	l/min (US gpm)	Flow
M	Nm (lbf in)	Torque
P	kW (HP)	Power
V	cm ³ /rev (in ³ /rev)	Displacement
n	min ⁻¹	Speed
Δp	bar (psi)	Pressure
$\eta_v = \eta_v(V, \Delta p, n)$		Volumetric efficiency
$\eta_{hm} = \eta_{hm}(V, \Delta p, n)$		Hydro-mechanical efficiency
$\eta_t = \eta_v \cdot \eta_{hm}$		Overall efficiency



DESIGN CALCULATIONS FOR PUMP

$$Q = Q_{theor.} \cdot \eta_v \quad [l/min]$$

$$Q_{theor.} = \frac{V \cdot n}{1000} \quad [l/min]$$

$$M = \frac{M_{theor.}}{\eta_{hm}} \quad [Nm]$$

$$M_{theor.} = \frac{\Delta p \cdot V}{62,83} \quad [Nm]$$

$$P_{IN} = \frac{P_{OUT}}{\eta_t} \quad [kW]$$

$$P_{OUT} = \frac{\Delta p \cdot Q}{600} \quad [kW]$$

DESIGN CALCULATIONS FOR MOTOR

$$Q = \frac{Q_{theor.}}{\eta_v} \quad [l/min]$$

$$Q_{theor.} = \frac{V \cdot n}{1000} \quad [l/min]$$

$$M = M_{theor.} \cdot \eta_{hm} \quad [Nm]$$

$$M_{theor.} = \frac{\Delta p \cdot V}{62,83} \quad [Nm]$$

$$P_{IN} = \frac{\Delta p \cdot Q}{600} \quad [kW]$$

$$P_{OUT} = P_{IN} \cdot \eta_t \quad [kW]$$

05/05.2023

GEAR PUMPS PERFORMANCE CURVES

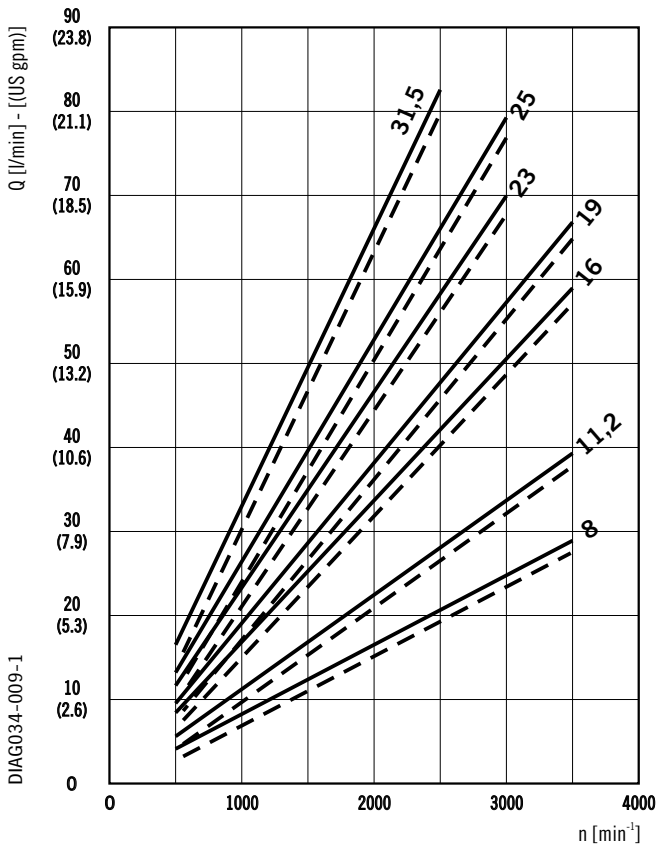

Each curve has been obtained at 50°C (122 °F), using oil with viscosity 46 cSt (210 SSU) at 40°C (104 °F) and at these pressures.

PHP 20•8	————	20 bar (290 psi)
	- - - -	250 bar (3625 psi)
PHP 20•11,2	————	20 bar (290 psi)
	- - - -	250 bar (3625 psi)
PHP 20•16	————	20 bar (290 psi)
	- - - -	250 bar (3625 psi)
PHP 20•19	————	20 bar (290 psi)
	- - - -	250 bar (3625 psi)
PHP 20•23	————	20 bar (290 psi)
	- - - -	250 bar (3625 psi)
PHP 20•25	————	20 bar (290 psi)
	- - - -	230 bar (3335 psi)
PHP 20•31,5	————	20 bar (290 psi)
	- - - -	200 bar (2900 psi)

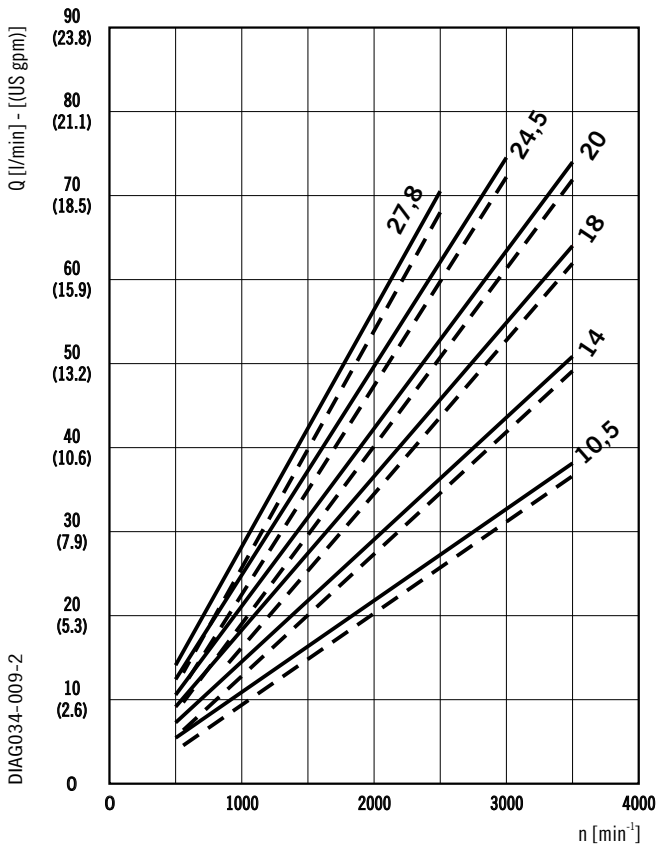

PHP 20•10,5	————	20 bar (290 psi)
	- - - -	250 bar (3625 psi)
PHP 20•14	————	20 bar (290 psi)
	- - - -	250 bar (3625 psi)
PHP 20•18	————	20 bar (290 psi)
	- - - -	250 bar (3625 psi)
PHP 20•20	————	20 bar (290 psi)
	- - - -	250 bar (3625 psi)
PHP 20•24,5	————	20 bar (290 psi)
	- - - -	230 bar (3335 psi)
PHP 20•27,8	————	20 bar (290 psi)
	- - - -	200 bar (2900 psi)

04/01.2019

GEAR PUMPS PERFORMANCE CURVES

PHP 20•8

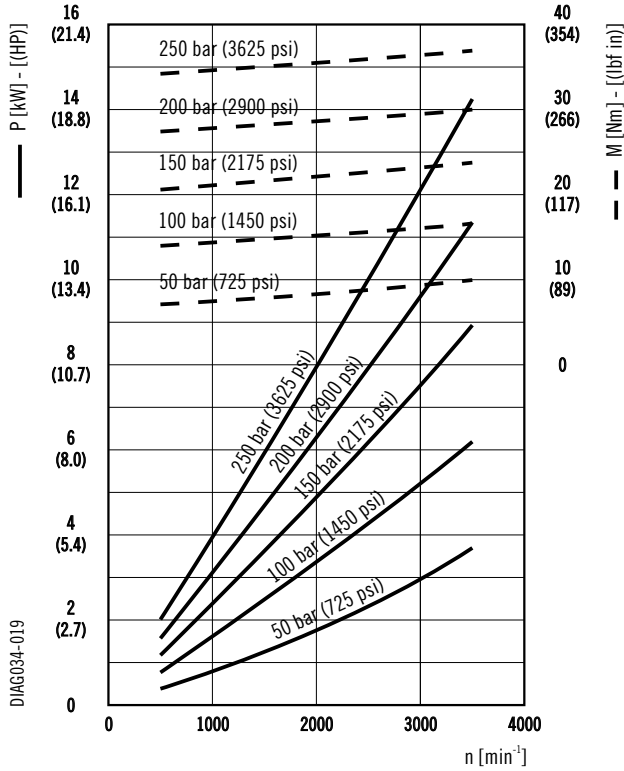

PHP 20•10,5

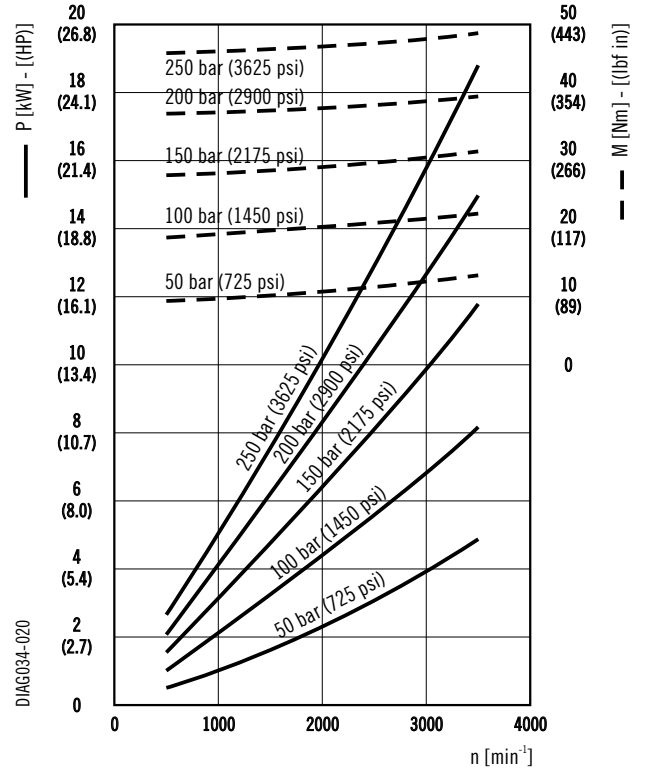

PHP 20•11,2

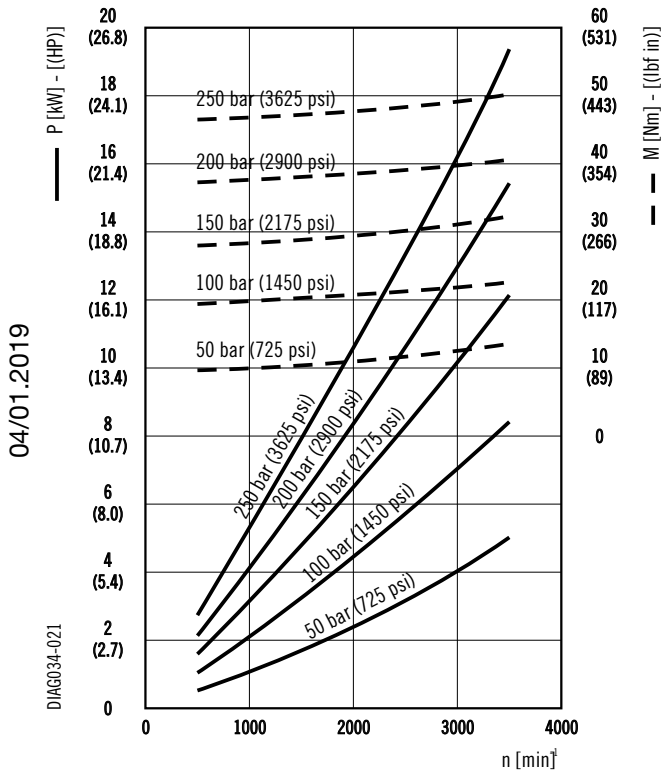

PHP 20•14

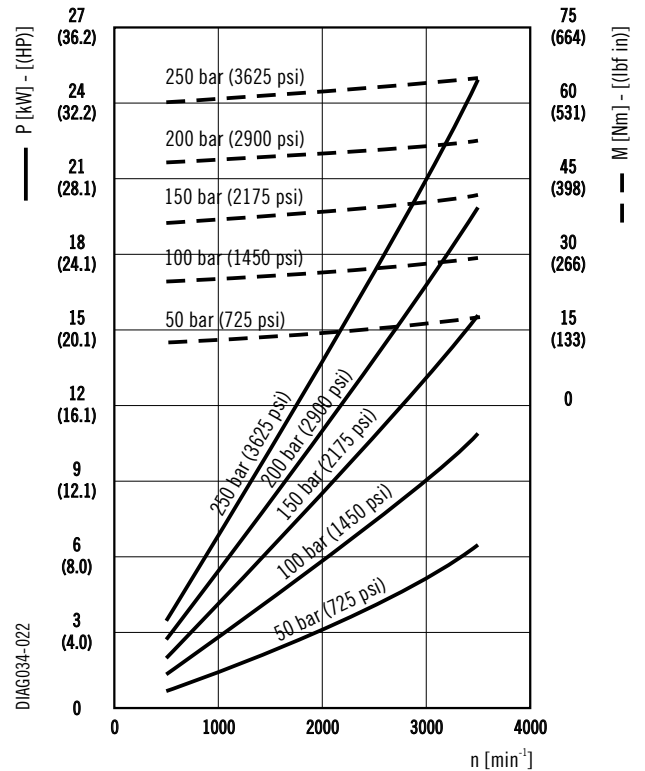

GEAR PUMPS PERFORMANCE CURVES

PHP 20•16

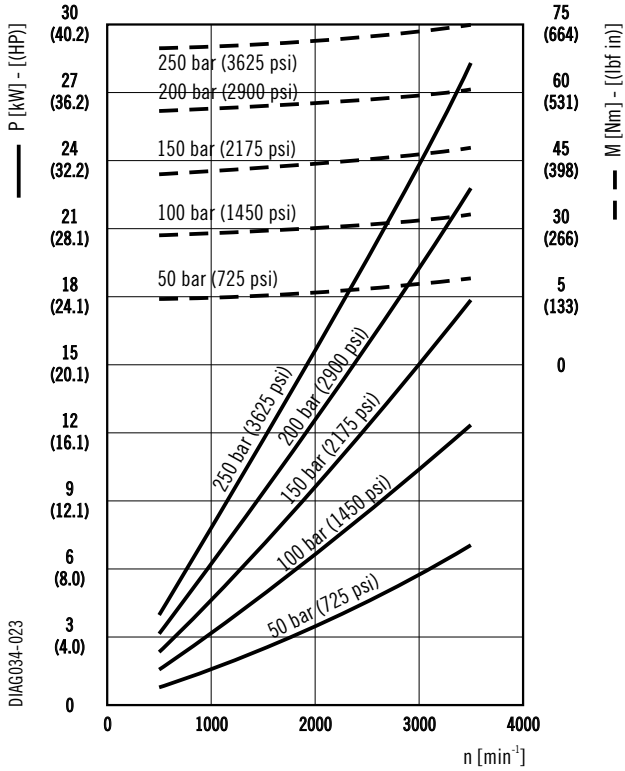

PHP 20•18

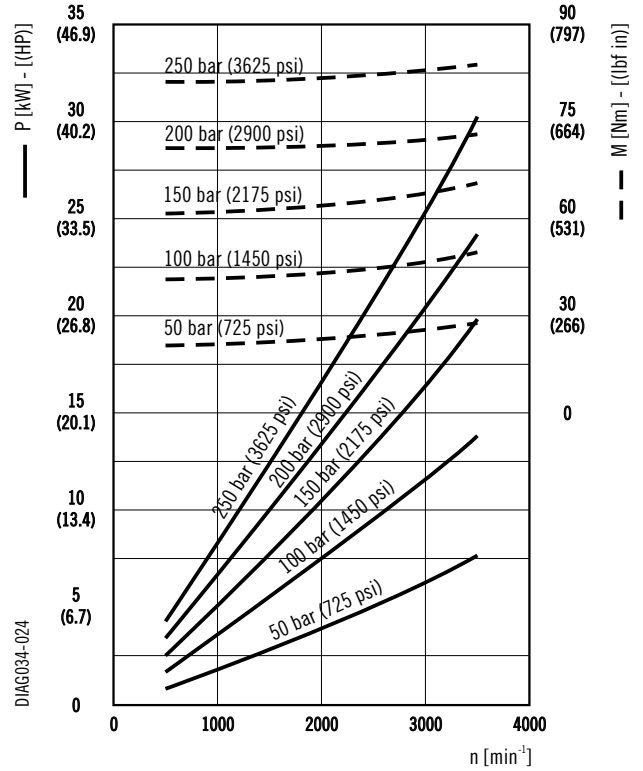

PHP 20•19

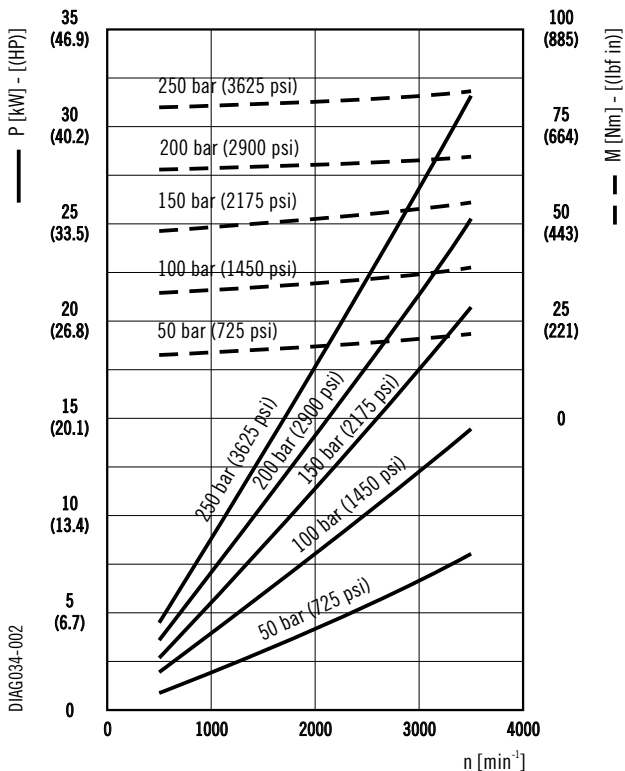

PHP 20•20

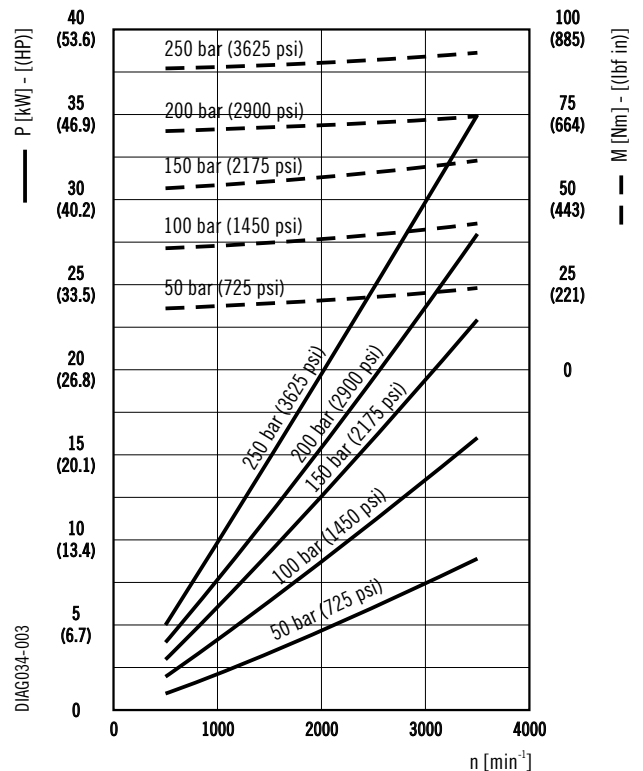

04/01.2019

GEAR PUMPS PERFORMANCE CURVES

PHP 20•23

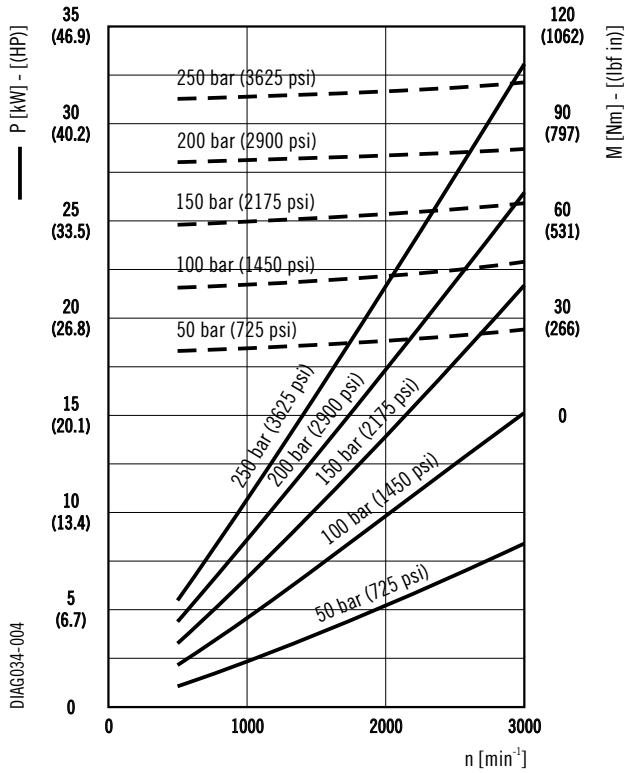

PHP 20•24,5

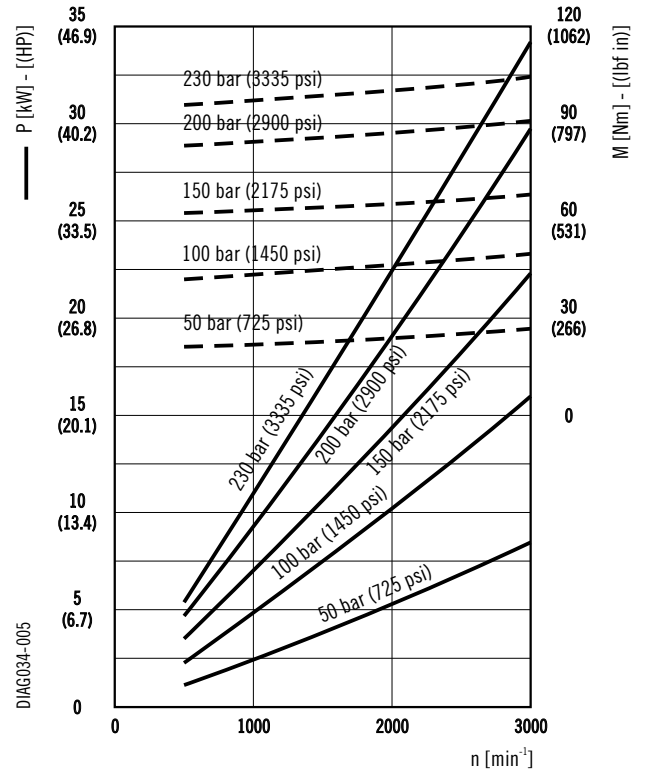

PHP 20•25

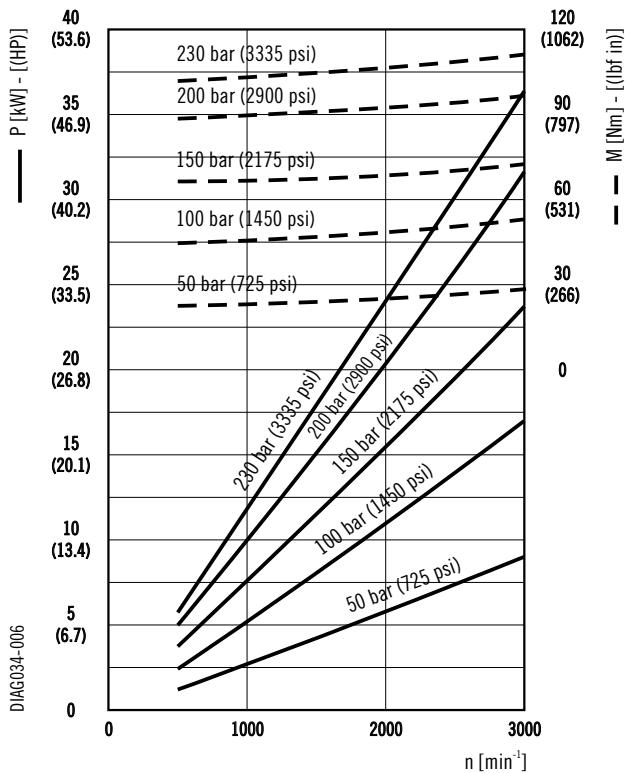

PHP 20•27,8

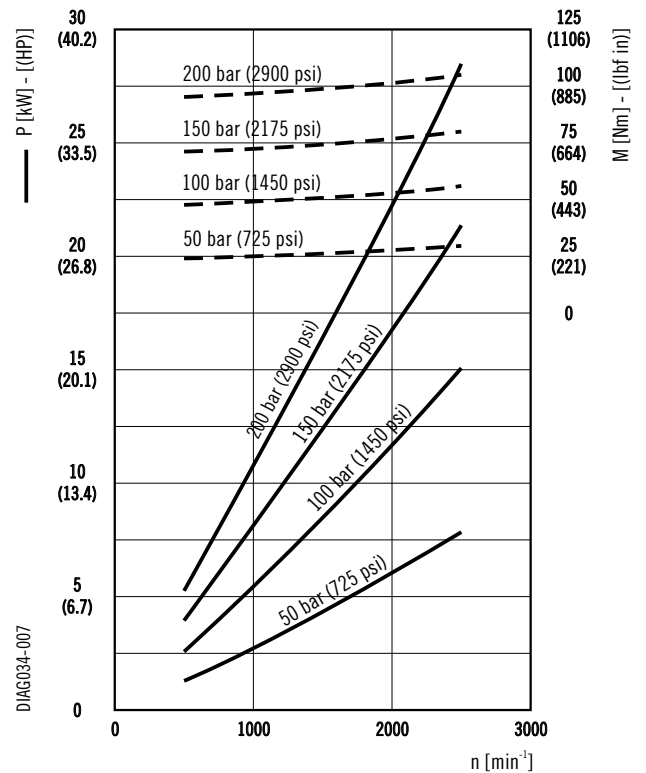

01/06.2009

GEAR PUMPS PERFORMANCE CURVES

PHP 20•31,5

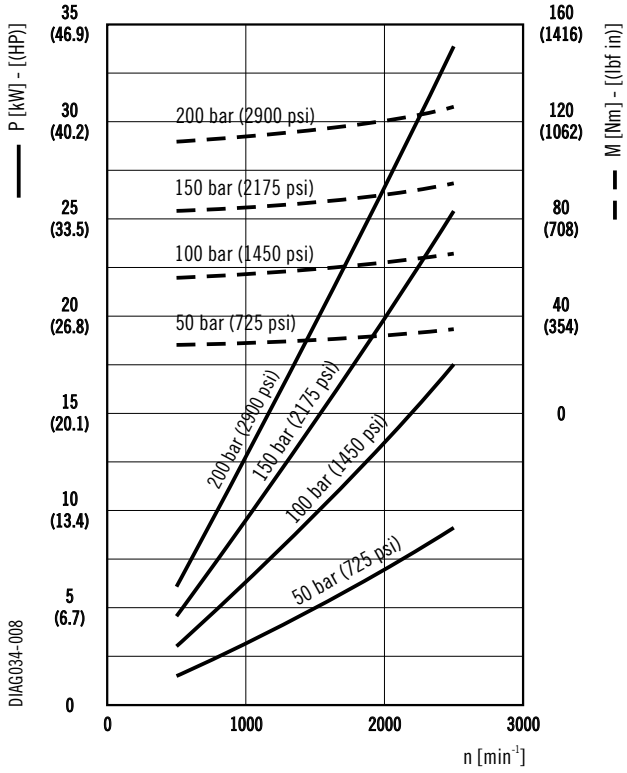

01/06.2009

GEAR MOTORS PERFORMANCE CURVES

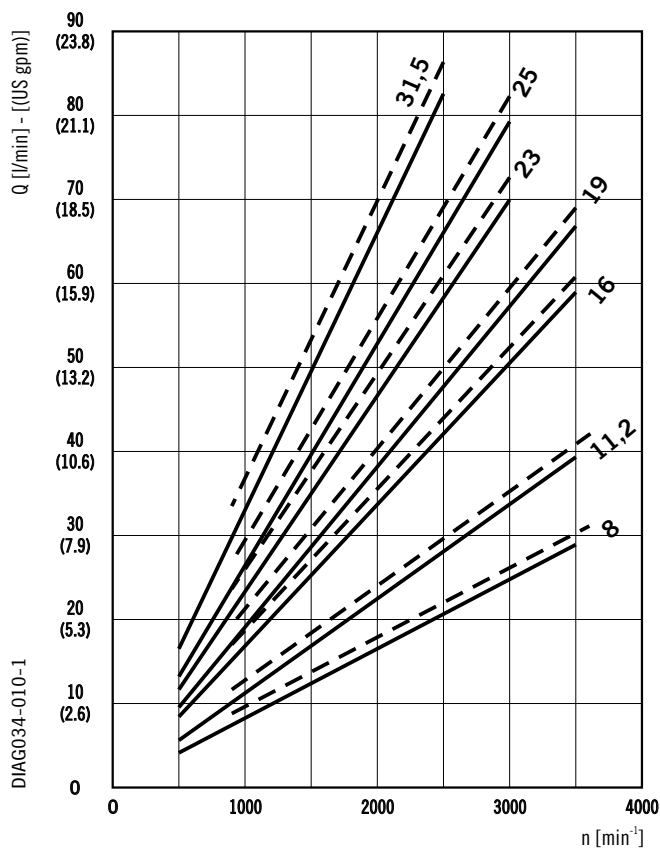

Each curve has been obtained at 50°C (122 °F), using oil with viscosity 46 cSt (210 SSU) at 40°C (104 °F) and at these pressures.

PHM 20•8	————	20 bar (290 psi)
	- - - -	250 bar (3625 psi)
PHM 20•11,2	————	20 bar (290 psi)
	- - - -	250 bar (3625 psi)
PHM 20•16	————	20 bar (290 psi)
	- - - -	250 bar (3625 psi)
PHM 20•19	————	20 bar (290 psi)
	- - - -	250 bar (3625 psi)
PHM 20•23	————	20 bar (290 psi)
	- - - -	250 bar (3625 psi)
PHM 20•25	————	20 bar (290 psi)
	- - - -	230 bar (3335 psi)
PHM 20•31,5	————	20 bar (290 psi)
	- - - -	200 bar (2900 psi)

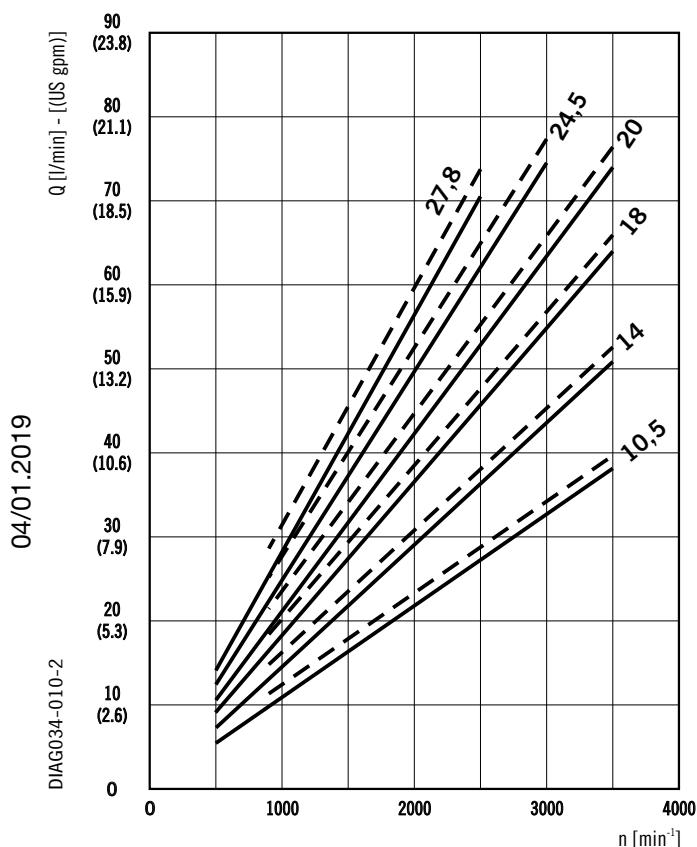

PHM 20•10,5	————	20 bar (290 psi)
	- - - -	250 bar (3625 psi)
PHM 20•14	————	20 bar (290 psi)
	- - - -	250 bar (3625 psi)
PHM 20•18	————	20 bar (290 psi)
	- - - -	250 bar (3625 psi)
PHM 20•20	————	20 bar (290 psi)
	- - - -	250 bar (3625 psi)
PHM 20•24,5	————	20 bar (290 psi)
	- - - -	230 bar (3335 psi)
PHM 20•27,8	————	20 bar (290 psi)
	- - - -	200 bar (2900 psi)

GEAR MOTORS PERFORMANCE CURVES

PHM 20•8

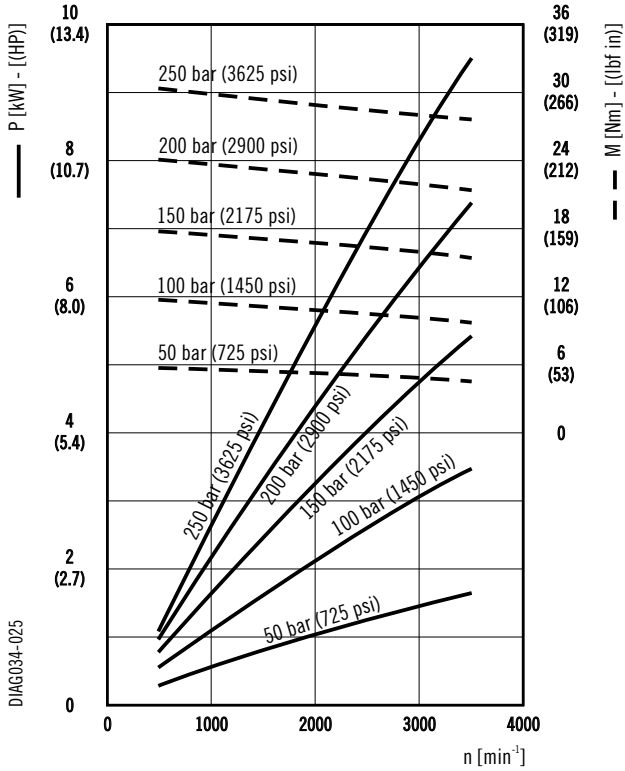

PHM 20•10,5

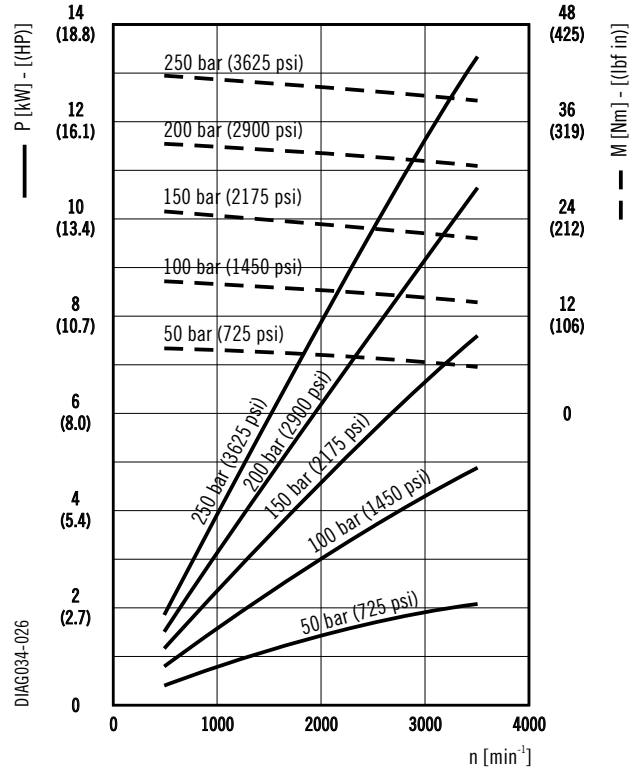

PHM 20•11,2

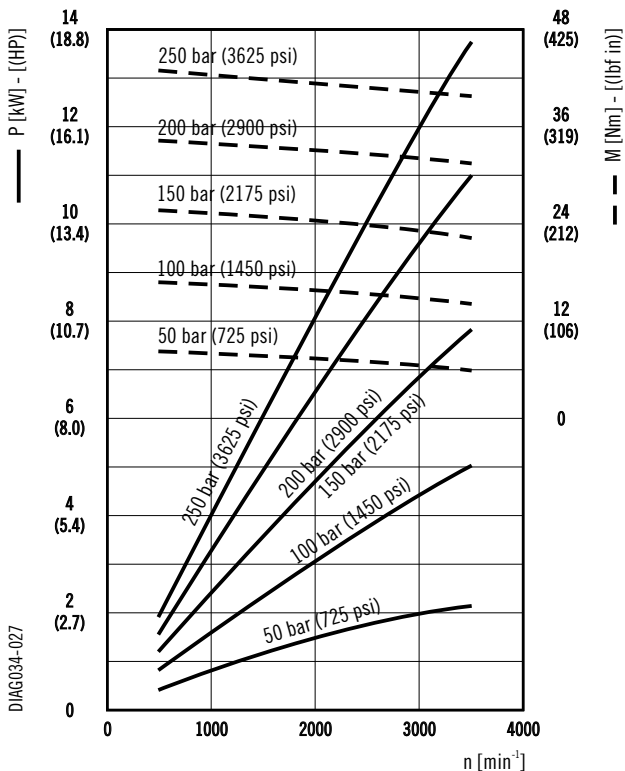

PHM 20•14

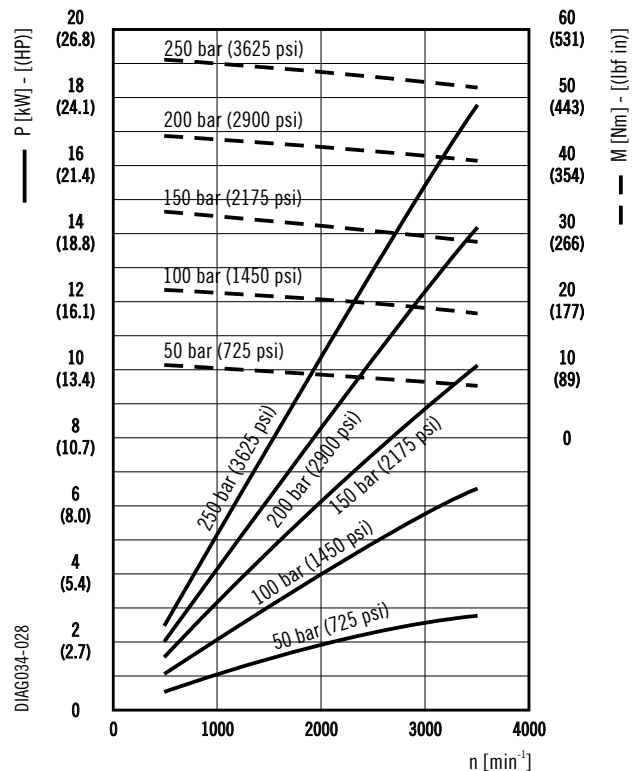

04/01.2019

GEAR MOTORS PERFORMANCE CURVES

PHM 20•16

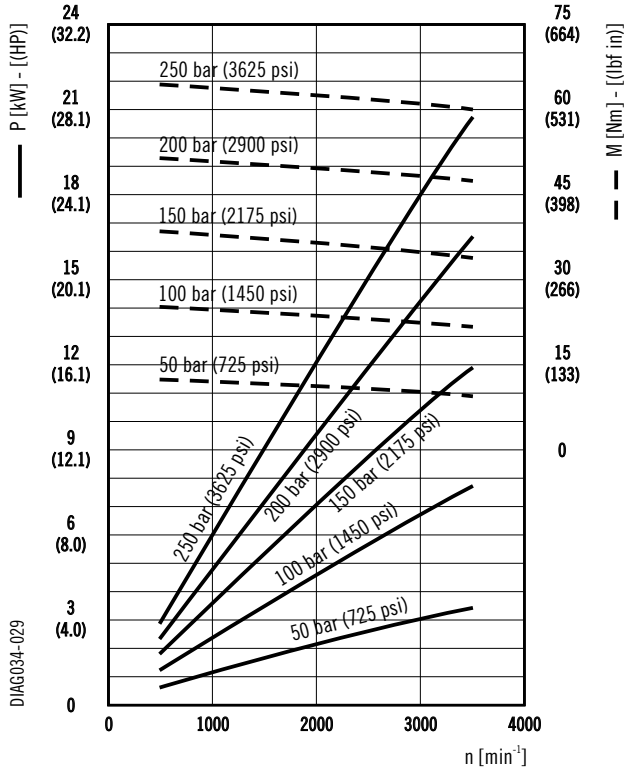

PHM 20•18

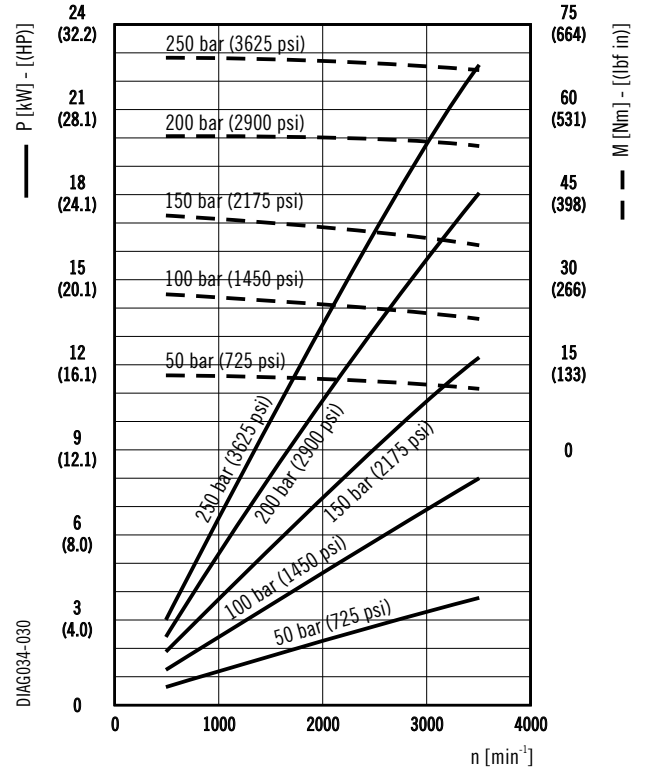

PHM 20•19

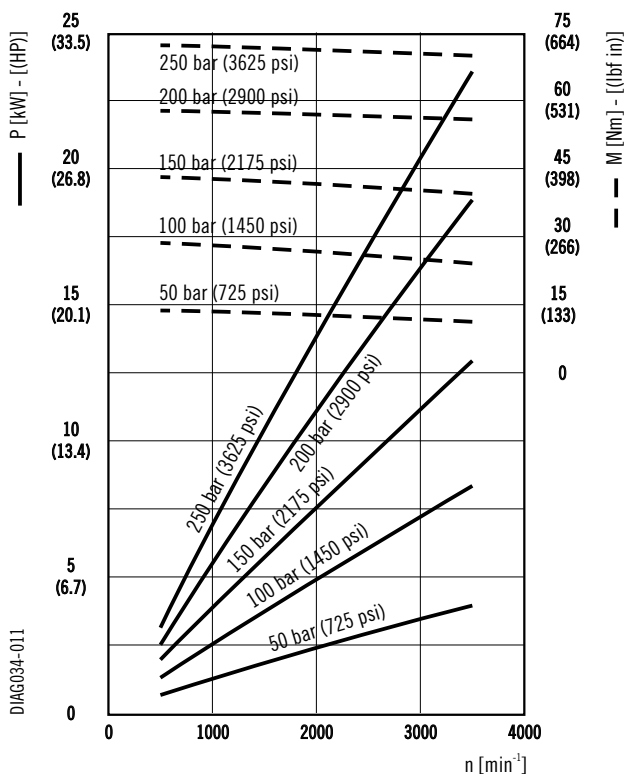

PHM 20•20

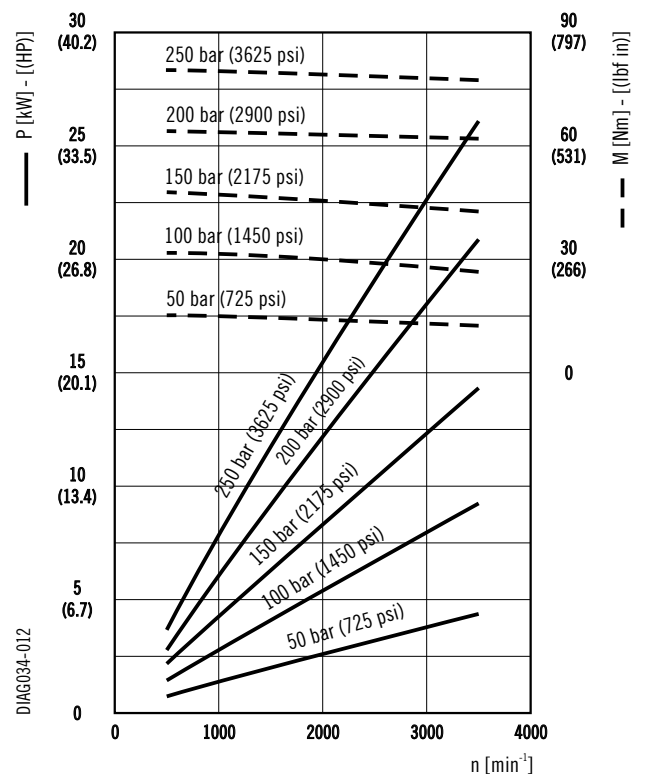

04/01.2019

GEAR MOTORS PERFORMANCE CURVES

PHM 20•23

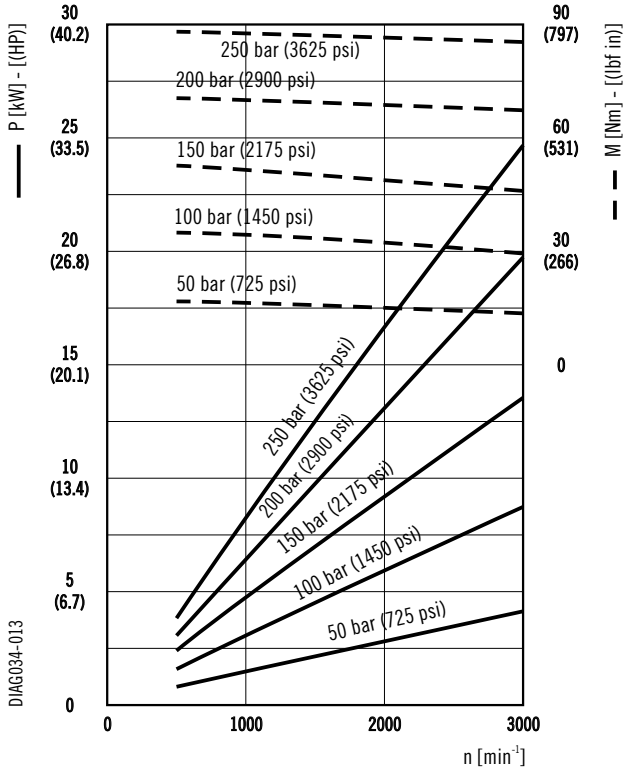

PHM 20•24,5

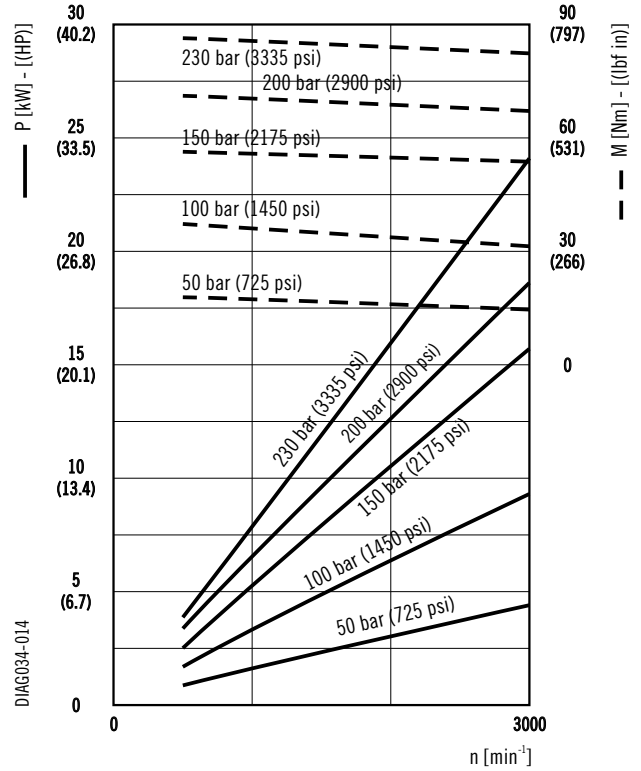

PHM 20•25

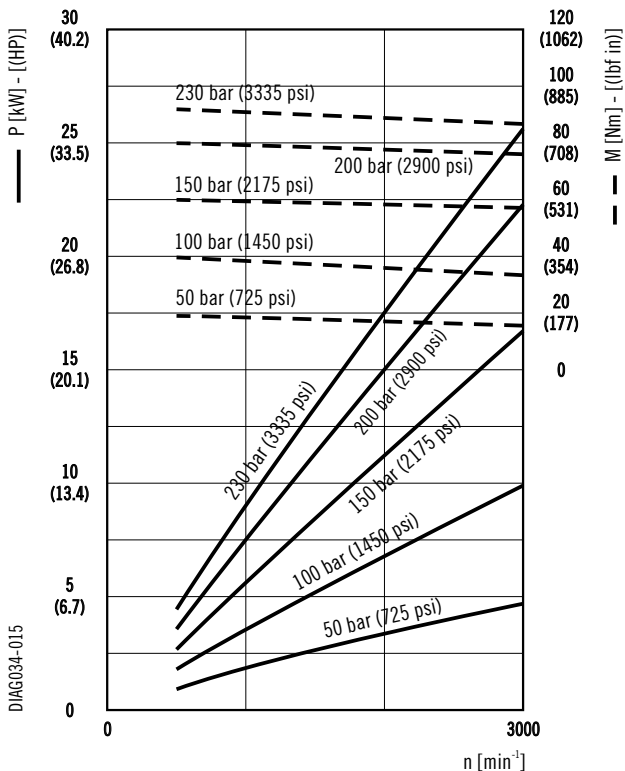

PHM 20•27,8

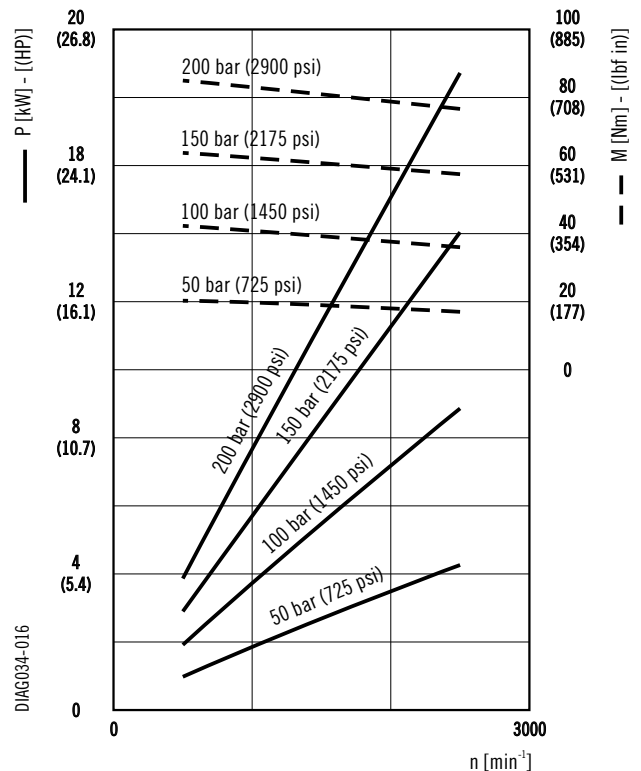

01/06.2009

GEAR MOTORS PERFORMANCE CURVES

PHM 20•31,5

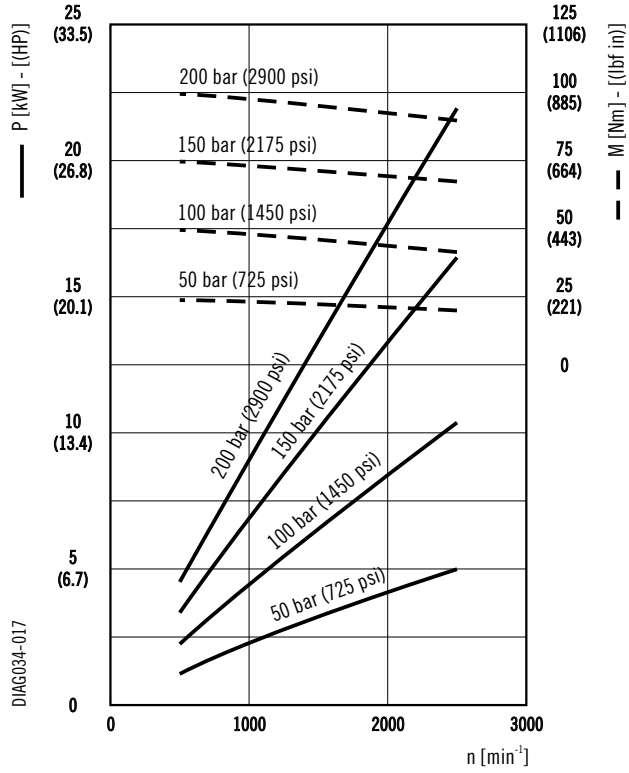

01/06.2009

POLARIS PH

SINGLE UNITS DIMENSIONS - SIDE PORTS

L

Drive shafts: page 31 ÷ 33

Mounting flange: for X dimension see page 34 ÷ 37

Ports availability: European, Split, Gas, SAE and German. See page 38

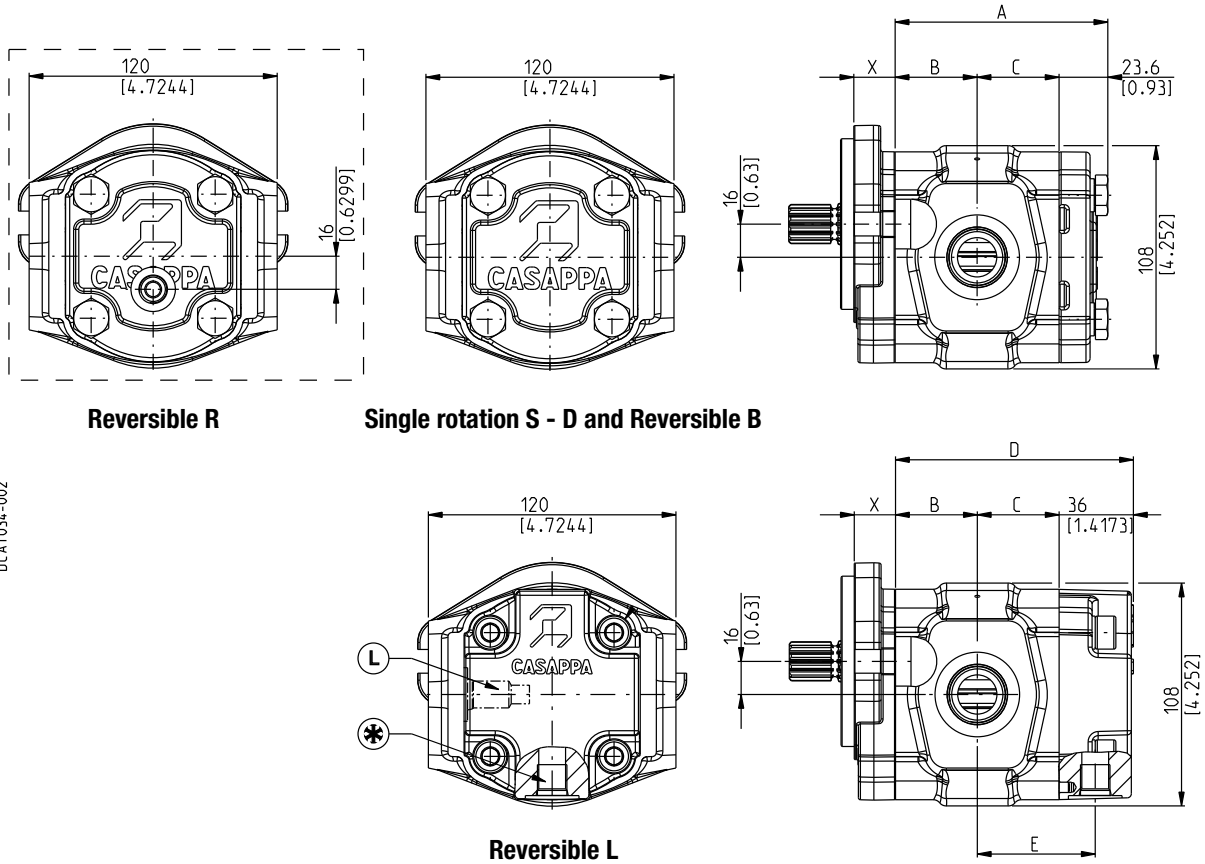

DCAT034-002

For single rotation S - D, reversible B and R the rear cover is available in cast iron and aluminium.
For reversible rotation L the rear cover is in aluminium only.

Reversible L drain port position:
L = Side
* = Bottom

Pump type Motor type	A	B	C	D	E
	mm (inch)	mm (inch)	mm (inch)	mm (inch)	mm (inch)
PH. 20•8	80,1 (3.15)	32,5 (1.28)	24 (0.94)	92,5 (3.64)	41,5 (1.63)
PH. 20•10,5	84,1 (3.31)	36,5 (1.44)	24 (0.94)	96,5 (3.80)	41,5 (1.63)
PH. 20•11,2	84,6 (3.33)	37 (1.46)	24 (0.94)	97 (3.82)	41,5 (1.63)
PH. 20•14	89,6 (3.53)	42 (1.65)	24 (0.94)	102 (4.02)	41,5 (1.63)
PH. 20•16	93 (3.66)	34,7 (1.37)	34,7 (1.37)	105,4 (4.15)	52,2 (2.06)
PH. 20•18	95,3 (3.75)	47,5 (1.87)	24,2 (0.95)	107,7 (4.24)	41,7 (1.64)
PH. 20•19	96,4 (3.80)	36,4 (1.43)	36,4 (1.43)	108,8 (4.28)	53,9 (2.12)
PH. 20•20	99,6 (3.92)	38 (1.50)	38 (1.50)	112 (4.41)	55,5 (2.19)
PH. 20•23	102,8 (4.05)	39,6 (1.56)	39,6 (1.56)	115,2 (4.54)	57,1 (2.25)
PH. 20•24,5	105,2 (4.14)	40,8 (1.61)	40,8 (1.61)	117,6 (4.63)	58,3 (2.30)
PH. 20•25	107,6 (4.24)	42 (1.65)	42 (1.65)	120 (4.72)	59,5 (2.34)
PH. 20•27,8	110,2 (4.34)	43,3 (1.70)	43,3 (1.70)	122,6 (4.83)	60,8 (2.39)
PH. 20•31,5	117,6 (4.63)	47 (1.85)	47 (1.85)	130 (5.12)	64,5 (2.54)

04/01.2019

POLARIS PH

SINGLE UNITS DIMENSIONS - REAR PORTS

P

Drive shafts: page 31 ÷ 33

Ports availability: Gas and SAE.

Mounting flange: for X dimension see
page 34 ÷ 37

See page 38

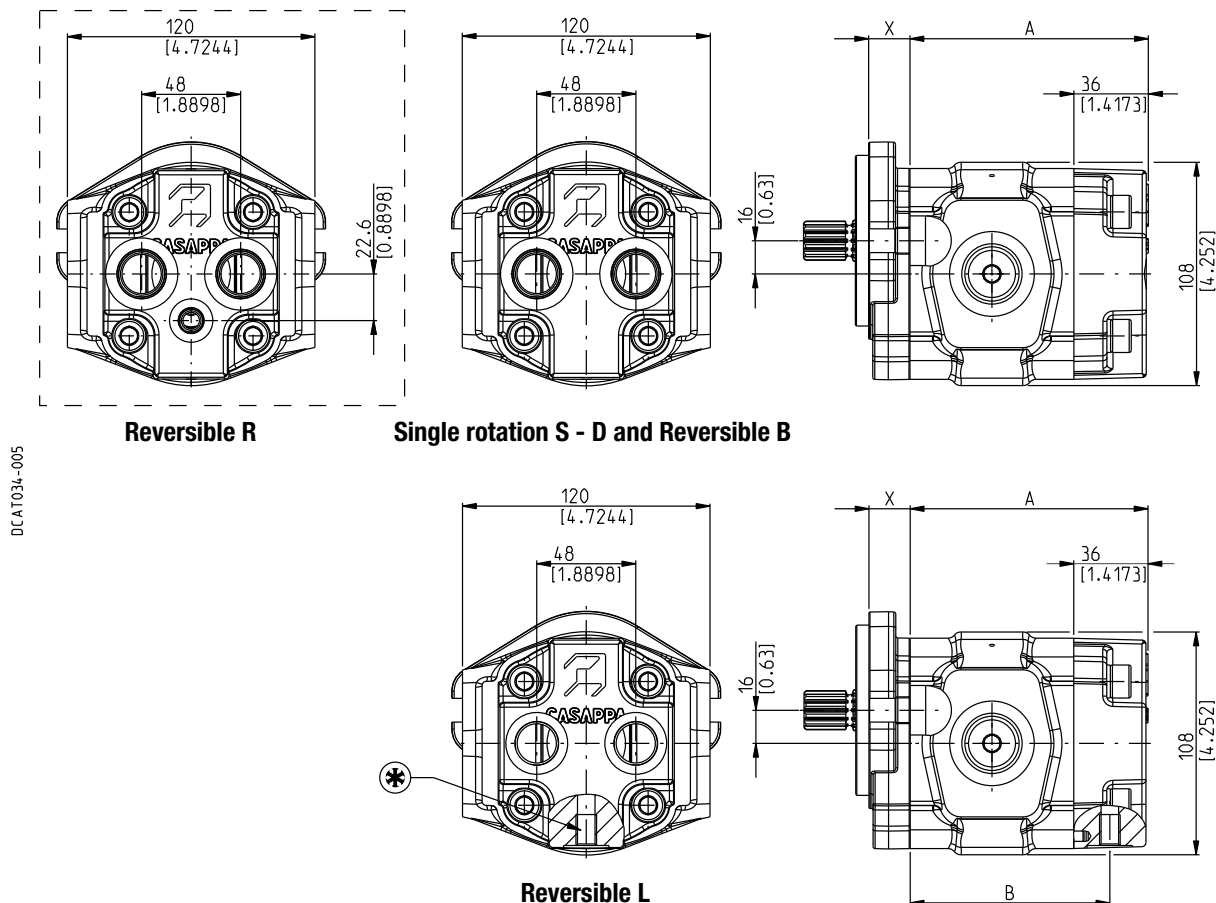

Rear cover in aluminium only.

Reversible L drain port position:

*= Bottom

04/01.2019

Pump type Motor type	A	B
	mm (inch)	mm (inch)
PH. 20•8	92,5 (3.64)	74 (.91)
PH. 20•10,5	96,5 (3.80)	78 (3.07)
PH. 20•11,2	97 (3.82)	78,5 (3.09)
PH. 20•14	102 (4.02)	83,5 (3.29)
PH. 20•16	105,4 (4.15)	86,9 (3.42)
PH. 20•18	107,7 (4.24)	89,2 (3.51)
PH. 20•19	108,8 (4.28)	90,2 (3.56)
PH. 20•20	112 (4.41)	93,5 (3.68)
PH. 20•23	115,2 (4.54)	96,7 (3.81)
PH. 20•24,5	117,6 (4.63)	99,1 (3.90)
PH. 20•25	120 (4.72)	101,5 (4.00)
PH. 20•27,8	122,6 (4.83)	104,1 (4.10)
PH. 20•31,5	130 (5.19)	111,5 (4.39)

MULTIPLE PUMPS

POLARIS PH series pumps can be coupled together in combination. Where the input power requirements of each section varies, that with the greater requirement must be at the drive shaft end, and progressively smaller to the rear.

Features and performances are the same as the corresponding single pumps, but pressures must be limited by the transmissible torque of the drive and connecting shafts. To have appropriate data, use the formula below.

The maximum rotational speed is the one of the lowest rated speed of the single units incorporated.

Available with common inlet and separated stages. Please contact us for more information.

M	Nm (lbf in)	Torque
V	cm ³ /rev (in ³ /rev)	Displacement
Δp	bar (psi)	Pressure
$\eta_{hm} = \eta_{hm}(V, \Delta p, n)$		Hydro-mechanical efficiency

$$M = \frac{M_{theor.}}{\eta_{hm}} \quad [Nm]$$

$$M_{theor.} = \frac{\Delta p \text{ (bar)} \cdot V \text{ (cm}^3\text{/rev)}}{62,83} \quad [Nm]$$

NOTE

The torque absorbed from the shaft of the first pump results from the sum of the torques of all the single stages. The achieved value must not exceed the maximum torque limit given for the shaft of the first pump.

03/05.2012

INLET PORTS CONFIGURATION

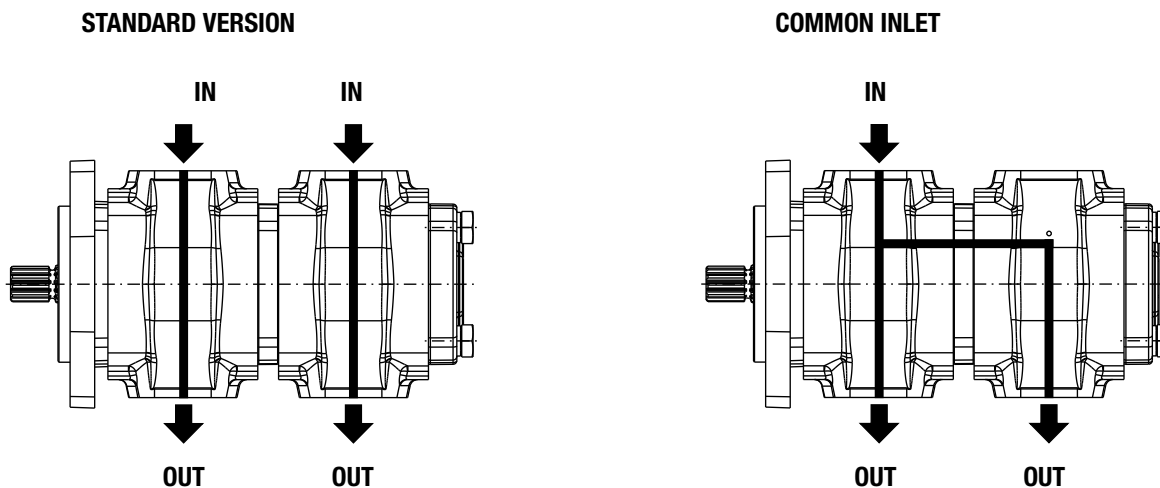

Reduced inlets provide overall systems savings by reducing the cost of redundant inlet hose and fittings. Please contact us for other combinations.

MULTIPLE PUMPS COMBINATION

PHP 20/20	STANDARD VERSION	S6
PHP 20/20	COMMON INLET VERSION	S7

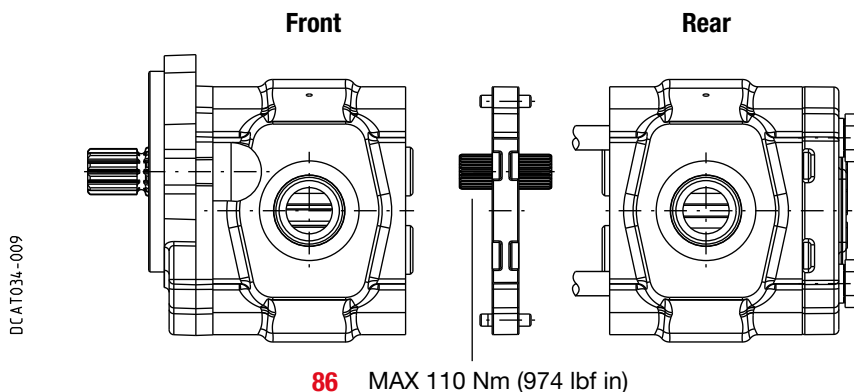

PHP 20/20	SEPARATED STAGES VERSION	Z6
-----------	--------------------------	----

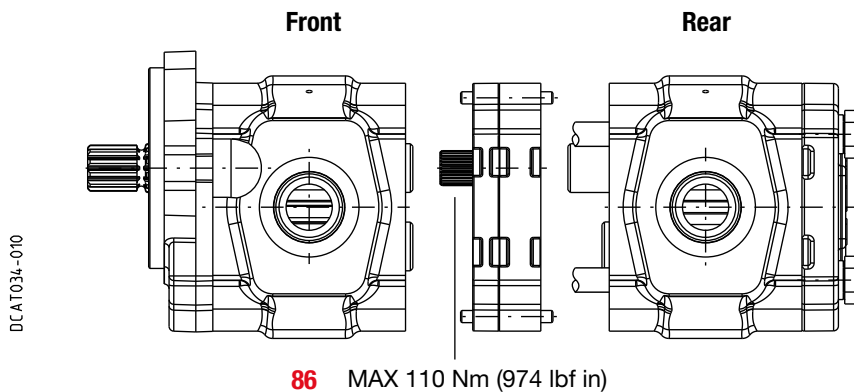

04/01.2019

MULTIPLE PUMPS COMBINATION

PHP 20/PLP20	STANDARD VERSION	S6
PHP 20/PLP20	COMMON INLET VERSION	S7

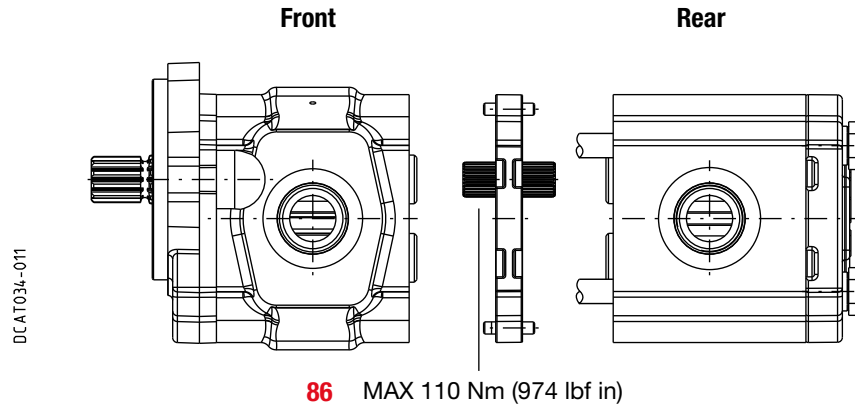

PHP 20/PLP20	SEPARATED STAGES VERSION	Z6
--------------	--------------------------	-----------

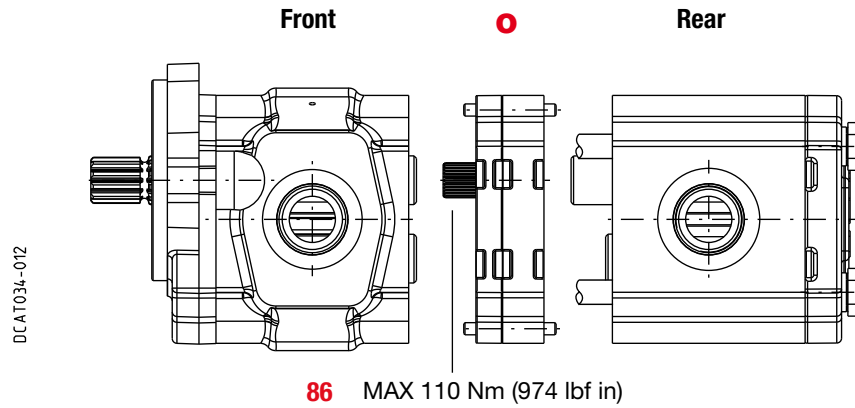

PHP 20/PLP10	STANDARD VERSION	S6
PHP 20/PLP10	COMMON INLET VERSION	T7

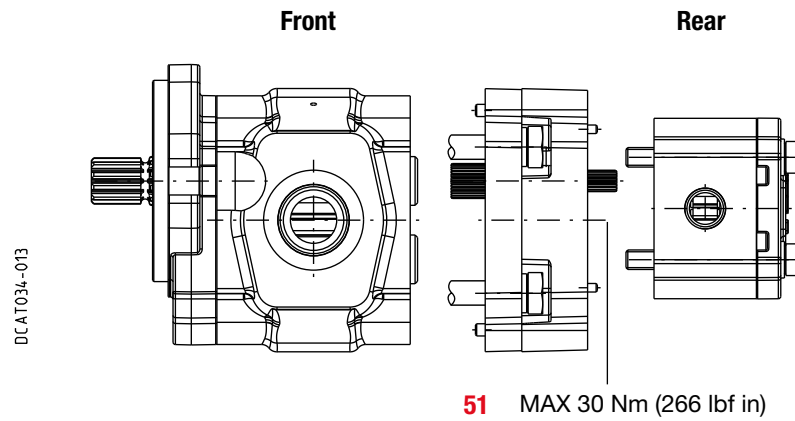

04/01.2019

MULTIPLE PUMPS COMBINATION

PHP 20/PLP10 SEPARATED STAGES VERSION

Z6

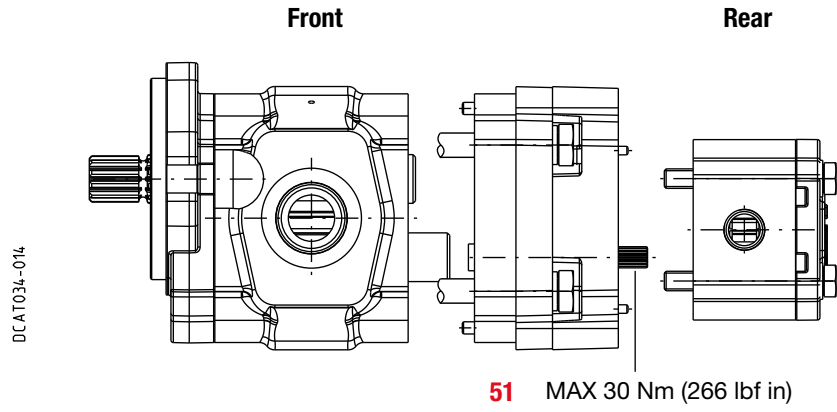

01/06.2009

POLARIS PH

MULTIPLE PUMPS DIMENSIONS

Drive shafts: page 31 ÷ 33
Mounting flange: for X dimension see page 34 ÷ 37

Ports availability: European, Split, Gas, SAE and German. See page 38

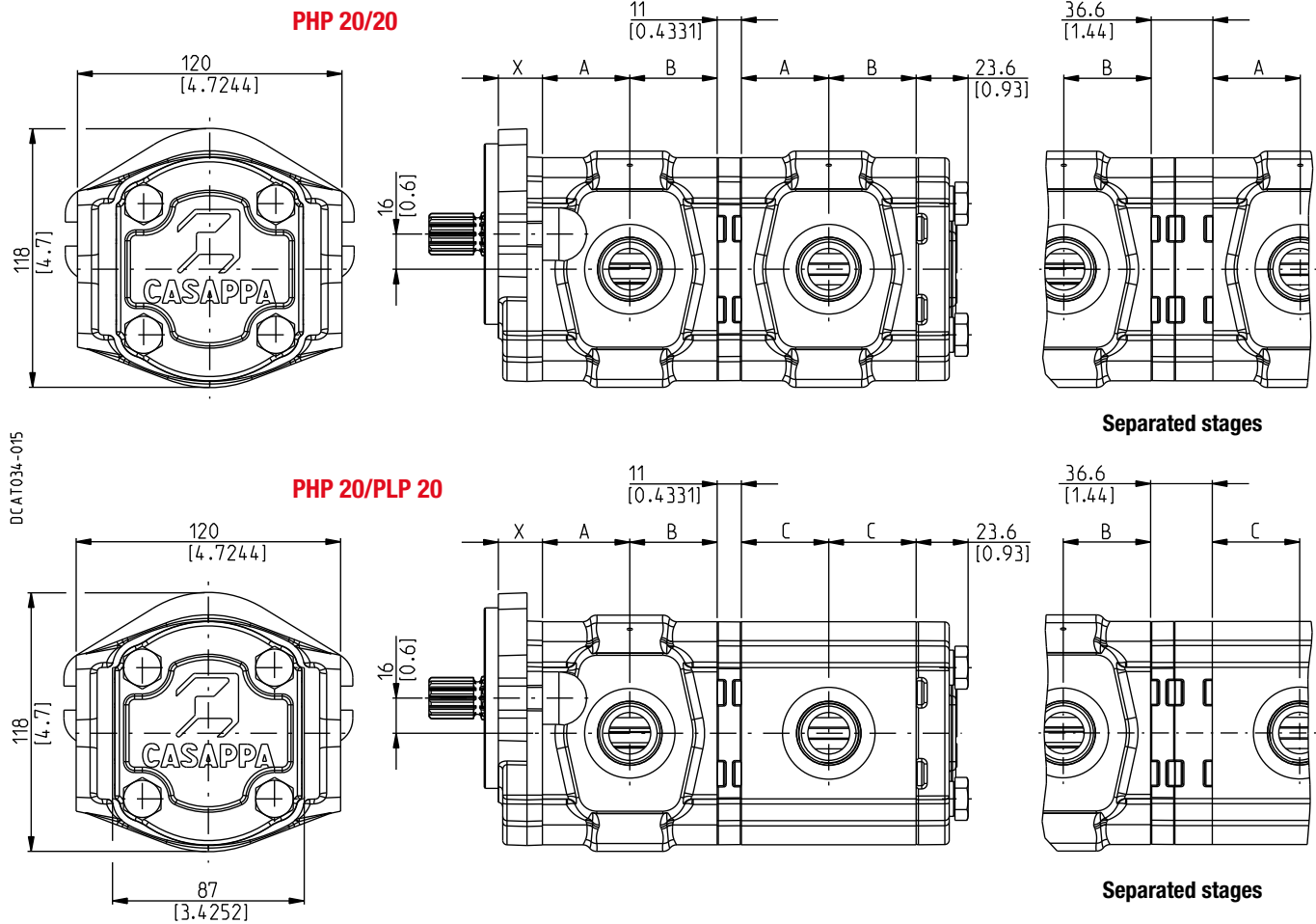

Rear cover in cast iron and aluminium.

Pump type	A	B
	mm (inch)	mm (inch)
PH. 20•8	32,5 (1.28)	24 (0.94)
PH. 20•10,5	36,5 (1.44)	24 (0.94)
PH. 20•11,2	37 (1.46)	24 (0.94)
PH. 20•14	42 (1.65)	24 (0.94)
PH. 20•16	34,7 (1.37)	34,7 (1.37)
PH. 20•18	47,5 (1.88)	24,2 (0.95)
PH. 20•19	36,4 (1.43)	36,4 (1.43)
PH. 20•20	38 (1.50)	38 (1.50)
PH. 20•23	39,6 (1.56)	39,6 (1.56)
PH. 20•24,5	40,8 (1.61)	40,8 (1.61)
PH. 20•25	42 (1.65)	42 (1.65)
PH. 20•27,8	43,3 (1.70)	43,3 (1.70)
PH. 20•31,5	47 (1.85)	47 (1.85)

Pump type	C
	mm (inch)
PLP 20•4	25,7 (1.01)
PLP 20•6,3	27 (1.06)
PLP 20•7,2	27,5 (1.08)
PLP 20•8	28,2 (1.11)
PLP 20•9	28,9 (1.14)
PLP 20•10,5	30,2 (1.19)
PLP 20•11,2	30,5 (1.20)
PLP 20•14	33 (1.30)
PLP 20•16	34,7 (1.31)
PLP 20•19	36,4 (1.43)
PLP 20•20	38 (1.50)
PLP 20•24,5	40,8 (1.61)
PLP 20•25	42 (1.65)
PLP 20•27,8	43,3 (1.70)
PLP 20•31,5	47 (1.85)

04/01.2019

POLARIS PH

MULTIPLE PUMPS DIMENSIONS

Drive shafts: page 31 ÷ 33
Mounting flange: for X dimension see page 34 ÷ 37

Ports availability: European, Split, Gas, SAE and German. See page 38

PHP 20/PLP 10

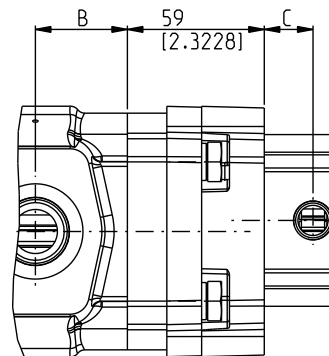
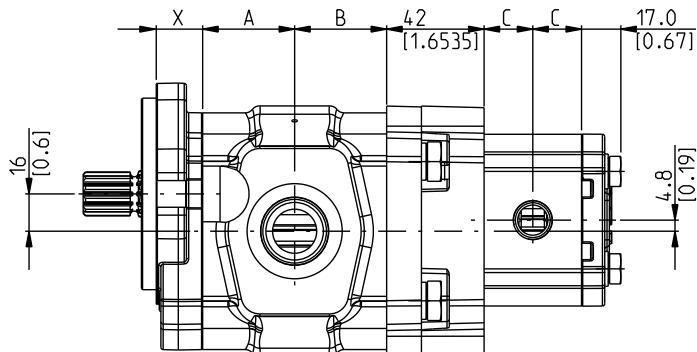
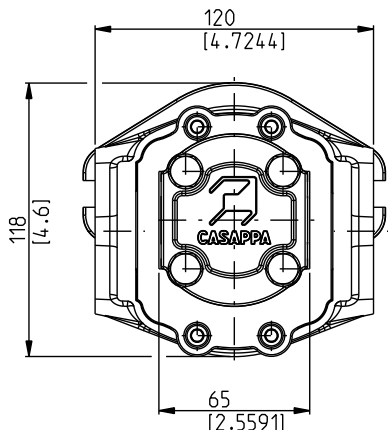

Separated stages

DCAT034-019

Rear cover in cast iron and aluminium.

Pump type	A	B
	mm (inch)	mm (inch)
PH. 20•8	32,5 (1.28)	24 (0.94)
PH. 20•10,5	36,5 (1.44)	24 (0.94)
PH. 20•11,2	37 (1.47)	24 (0.94)
PH. 20•14	42 (1.65)	24 (0.94)
PH. 20•16	34,7 (1.37)	34,7 (1.37)
PH. 20•18	47,5 (1.87)	24,2 (0.95)
PH. 20•19	36,4 (1.43)	36,4 (1.43)
PH. 20•20	38 (1.50)	38 (1.50)
PH. 20•23	39,6 (1.56)	39,6 (1.56)
PH. 20•24,5	40,8 (1.61)	40,8 (1.61)
PH. 20•25	42 (1.65)	42 (1.65)
PH. 20•27,8	43,3 (1.70)	43,3 (1.70)
PH. 20•31,5	47 (1.85)	47 (1.85)

Pump type	C
	mm (inch)
PLP 10•1	17,6 (0.69)
PLP 10•1,5	18,4 (0.72)
PLP 10•2	19,2 (0.76)
PLP 10•2,5	20 (0.79)
PLP 10•3,15	21 (0.83)
PLP 10•4	22,4 (0.88)
PLP 10•5	24 (0.94)
PLP 10•5,8	25,3 (1.00)
PLP 10•6,3	26 (1.02)
PLP 10•8	28,7 (1.13)
PLP 20•10	32 (1.26)

04/01.2019

OUTBOARD BEARING OPTIONS

For each version, the possible combination between drive shafts and mounting flanges are shown on pages 34 ÷ 37. For the outboard bearing life expectancy, diagrams providing approximate selection data will be found on subsequent pages. Please contact us for for particular applications.

VERSION

0

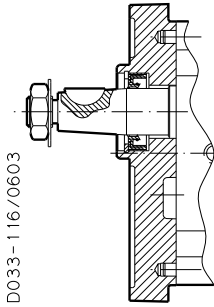

Version for applications without radial and axial load on the drive shaft.

VERSION

W8

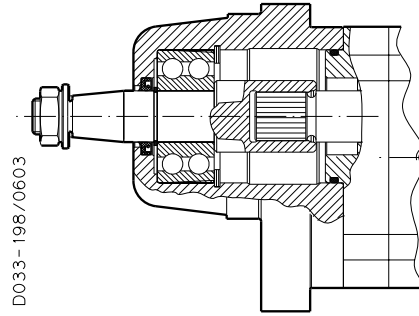

VERSION

4

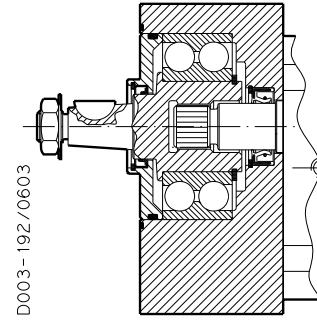

VERSION

5

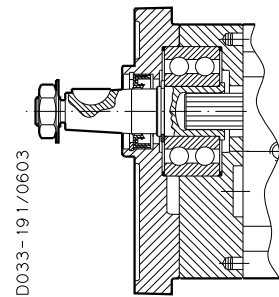

VERSION

6

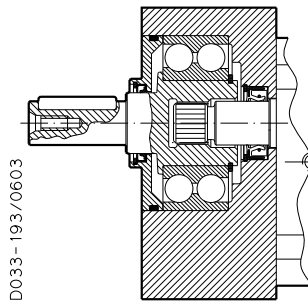

VERSION

7

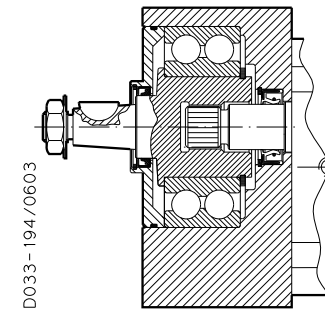

VERSION

8

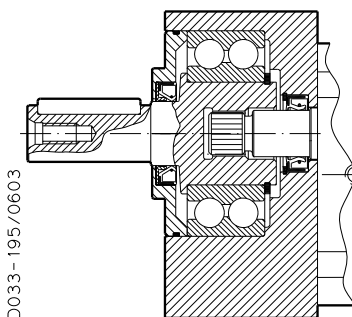

VERSION

9

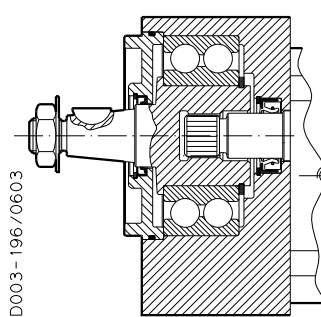

01/06.2009

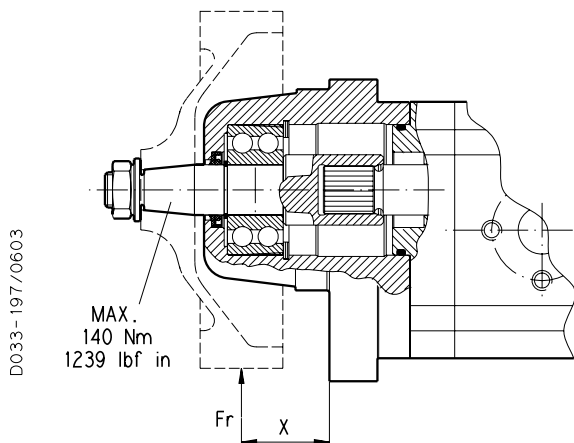

X = Distance of the radial load result from the mounting flange [mm (in)].

Each curve has been obtained at:

- Lubricant oil ISO VG 46
- Temperature 60 °C (140 °F)
- Without axial load
- Contamination level according ISO 281: $\beta_{12}(C) = 200$
- Reliability level of the calculation 90%

Example

Fr Radial load	1900 N (427.5 lbf)
X	20 mm (0.79 in)
Speed	2000 min ⁻¹
Rated fatigue life	≈ 3050 h

Values shown in the diagrams are indicative only. Please contact us for more information.

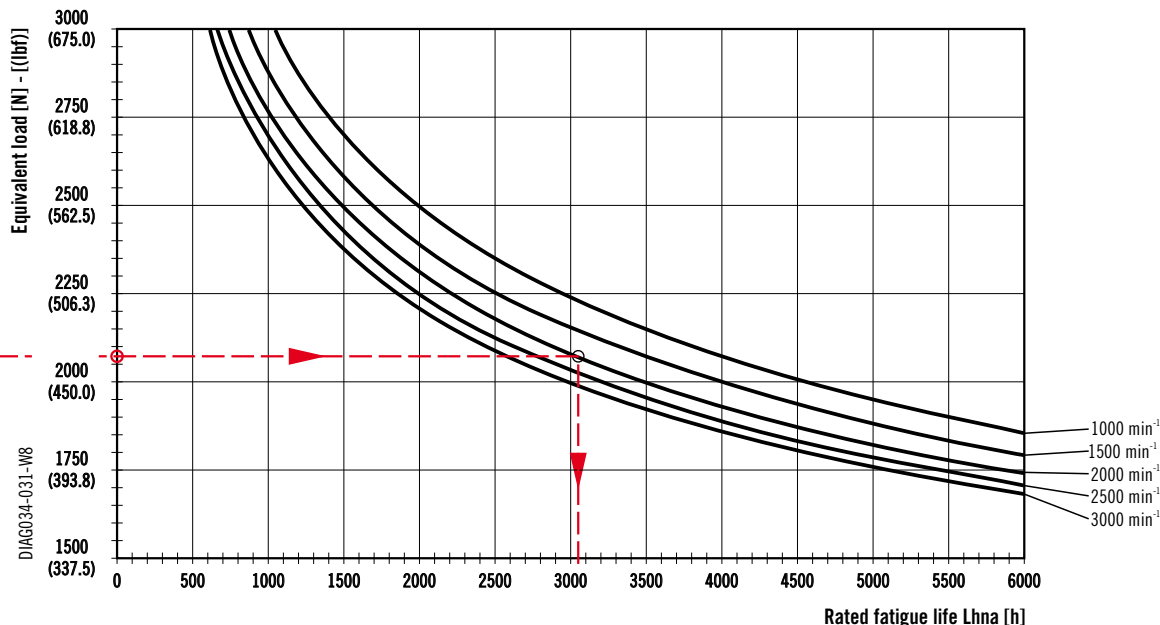
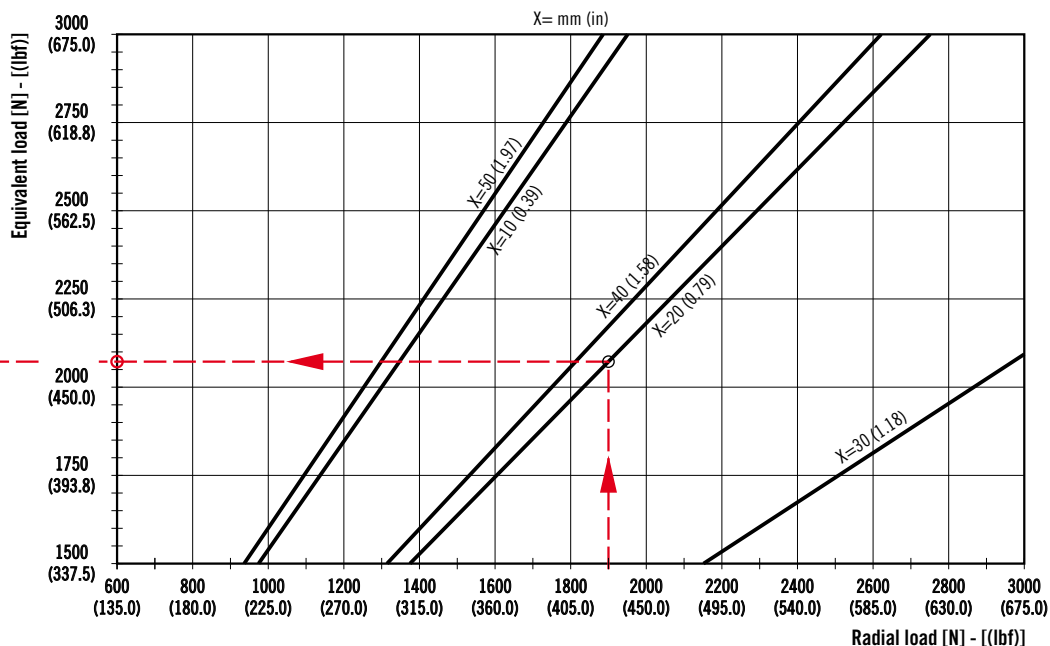

04/01.2019

DIAG034-031-W8

D003-114/0603

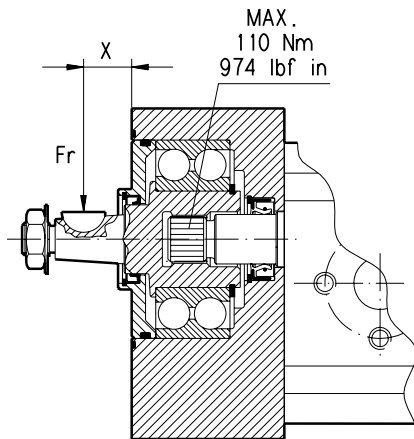

X = Distance of the radial load result from the mounting flange [mm (in)].

Each curve has been obtained at:

- Lubricant grease
- Temperature 60 °C (140 °F)
- Without axial load
- Contamination level according ISO 281: $\beta_{12}(C) = 200$
- Reliability level of the calculation 90%

Example

Fr Radial load	1700 N (382.5 lbf)
X	20 mm (0.79 in)
Speed	2000 min ⁻¹
Rated fatigue life	≈ 2100 h

Values shown in the diagrams are indicative only. Please contact us for more information.

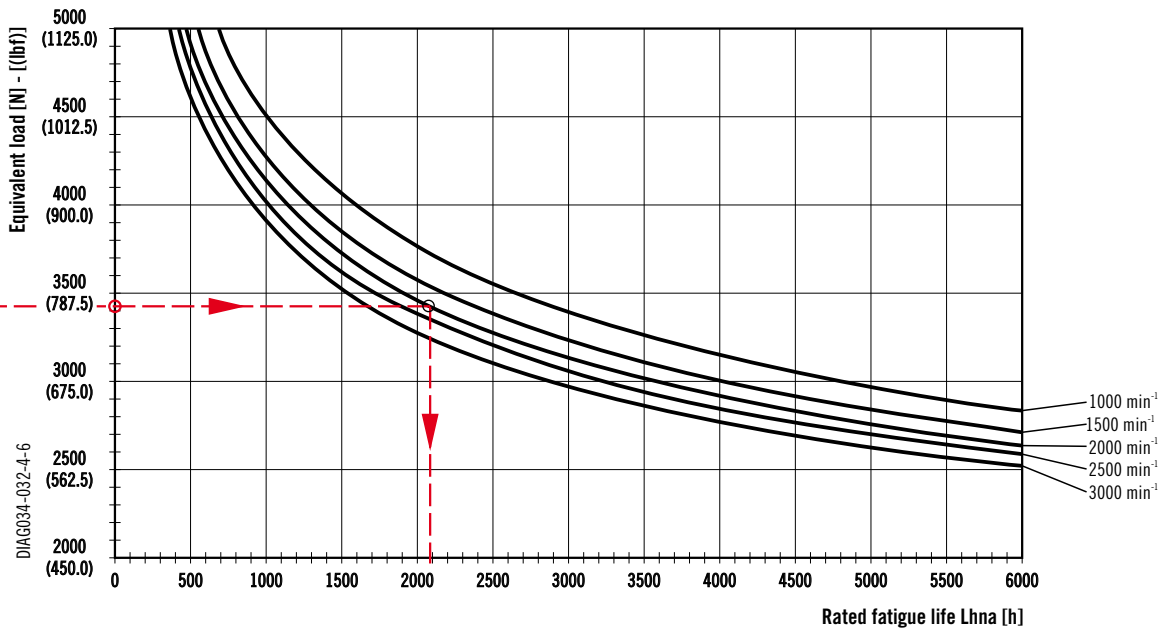
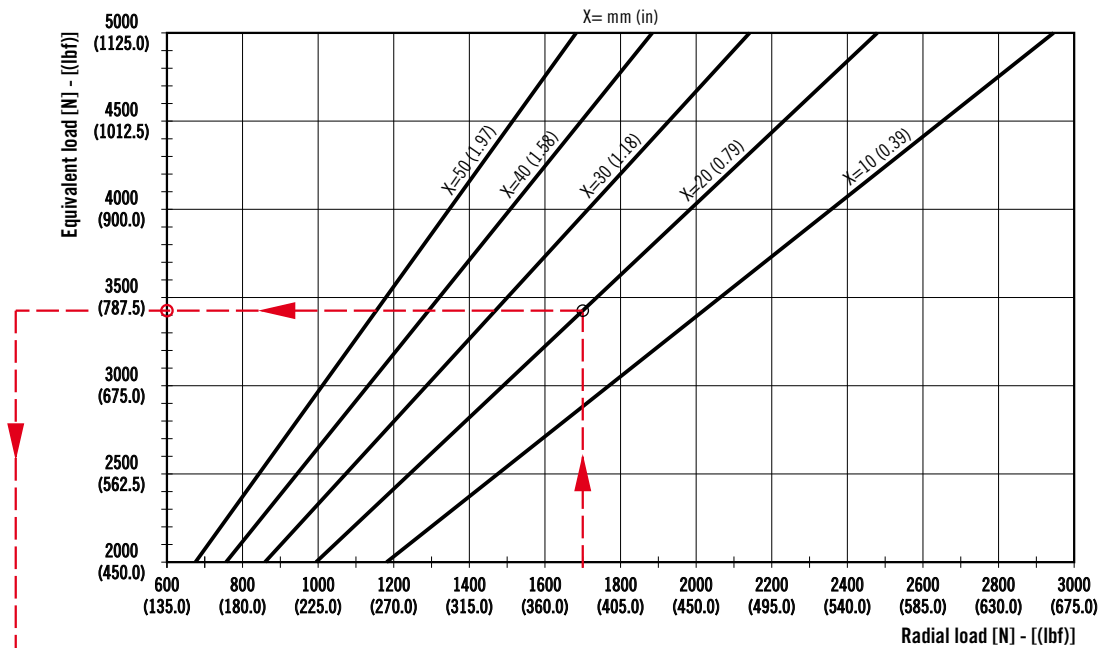

DIAG034-032-4-6

04/01.2019

D033-115/0603

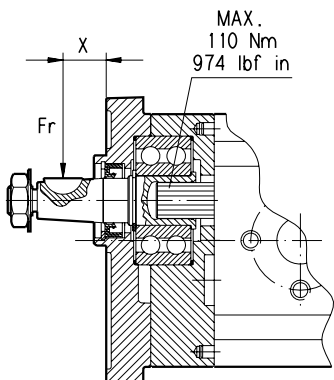

X = Distance of the radial load result from the mounting flange [mm (in)].

Each curve has been obtained at:

- Lubricant oil ISO VG 46
- Temperature 60 °C (140 °F)
- Without axial load
- Contamination level according ISO 281: $\beta_{12}(C) = 200$
- Reliability level of the calculation 90%

Example

Fr Radial load	850 N (191.3 lbf)
X	20 mm (0.79 in)
Speed	2000 min ⁻¹
Rated fatigue life	≈ 2100 h

Values shown in the diagrams are indicative only. Please contact us for more information.

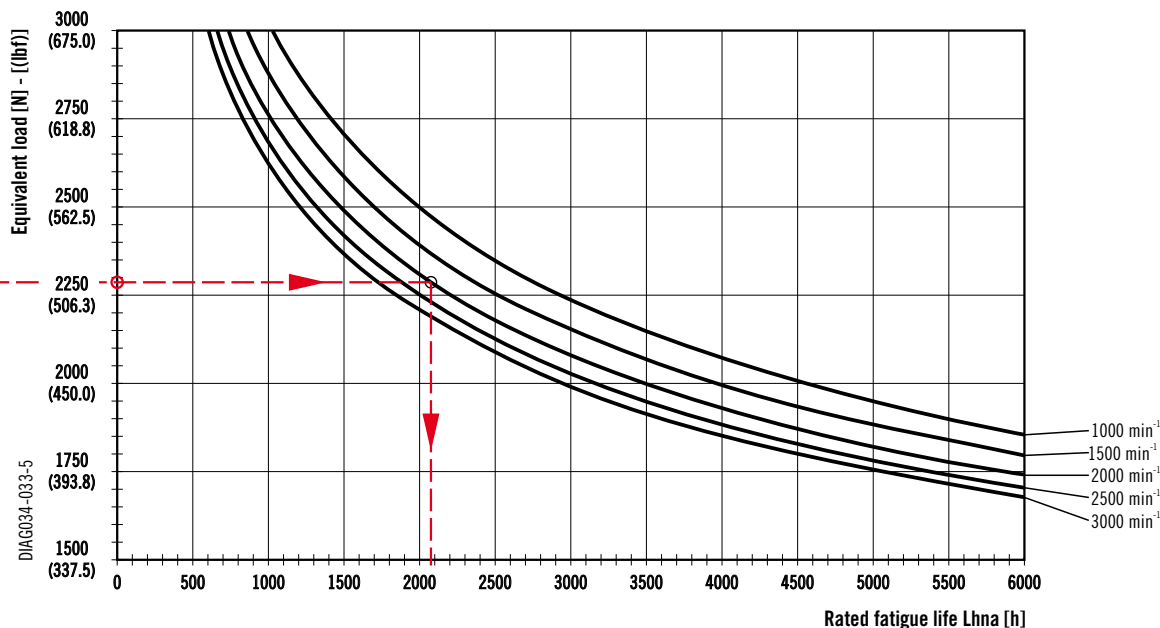
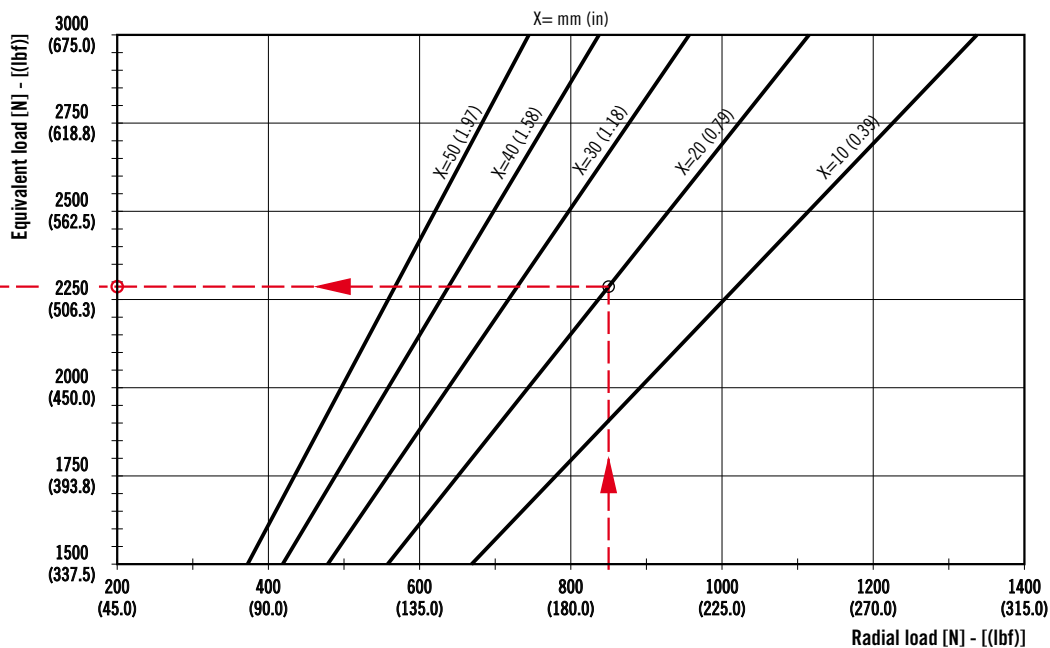

04/01.2019

DIAG034-033-5

D033 - 118/0603

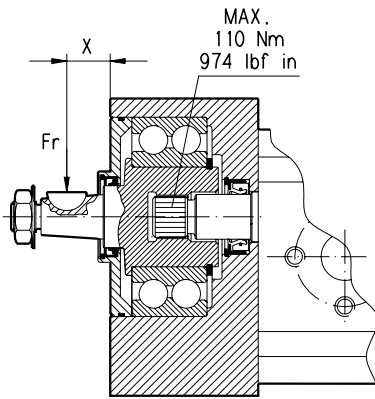

X = Distance of the radial load result from the mounting flange [mm (in)].

Each curve has been obtained at:

- Lubricant grease
- Temperature 60 °C (140 °F)
- Without axial load
- Contamination level according ISO 281: $\beta_{12}(C) = 200$
- Reliability level of the calculation 90%

Example

Fr Radial load	1900 N (427.5 lbf)
X	20 mm (0.79 in)
Speed	2000 min ⁻¹
Rated fatigue life	≈ 4600 h

Values shown in the diagrams are indicative only. Please contact us for more information.

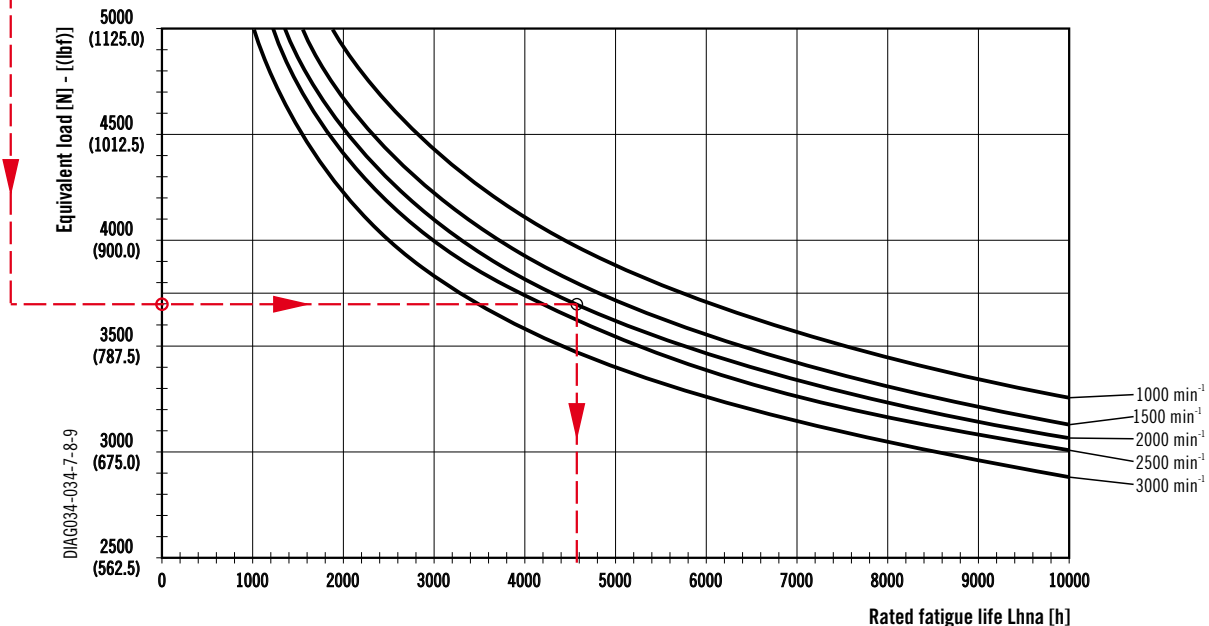
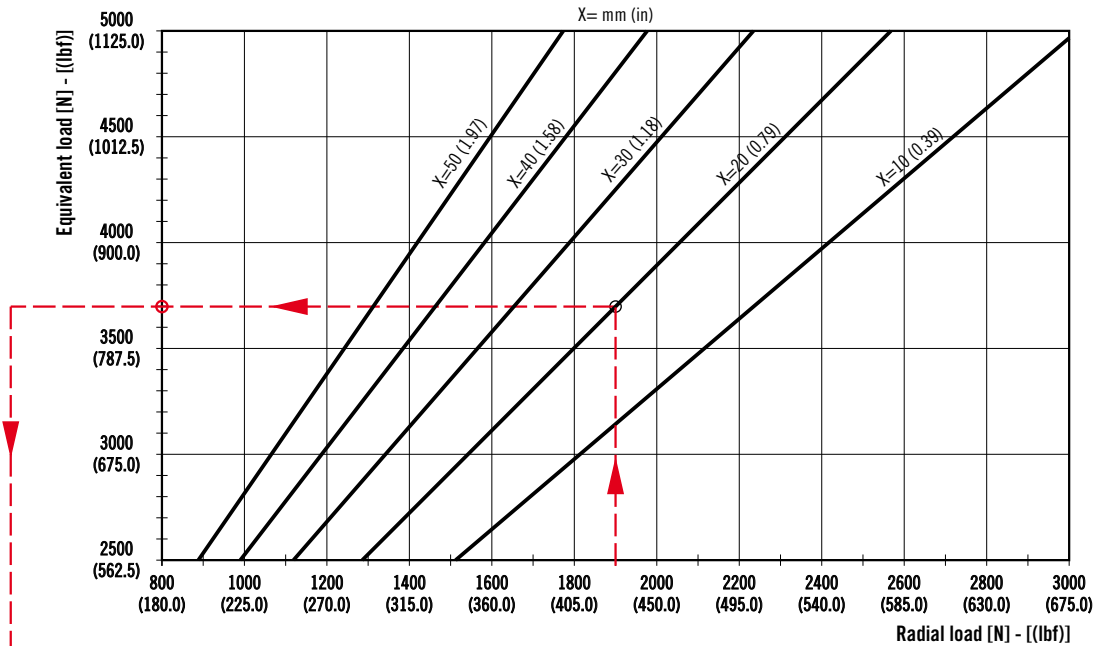

DIAG034-034-7-8-9

04/01.2019

DRIVE SHAFTS

EUROPEAN TAPERED 1:8

82

Not available with size:

20•24,5

Mounting face refer to flange code **E2**

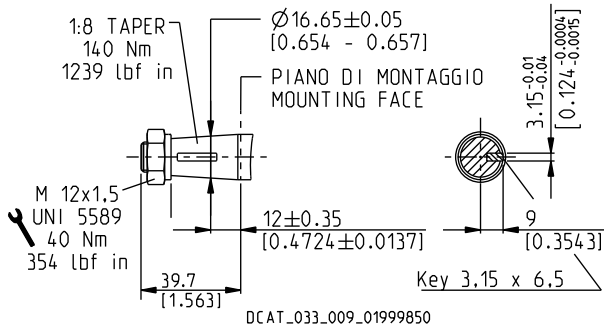

GERMAN TAPERED 1:5

54

Not available with size:

20•24,5

Mounting face refer to flange code **B2**

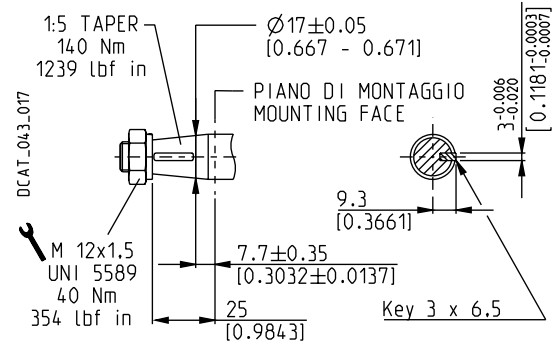

GERMAN TAPERED 1:5

55

Only for version **5, 9** and **W8** with outboard bearing

Mounting face refer to flange code **B2**

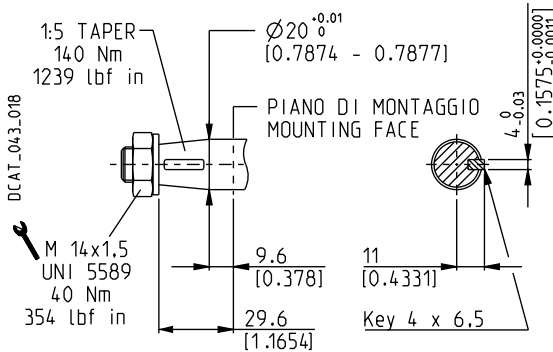

STRAIGHT

46

Not available with size:

20•10,5 - 20•18 - 20•19 - 20•23 - 20•24,5 - 20•27,8

Mounting face refer to flange code **E2**

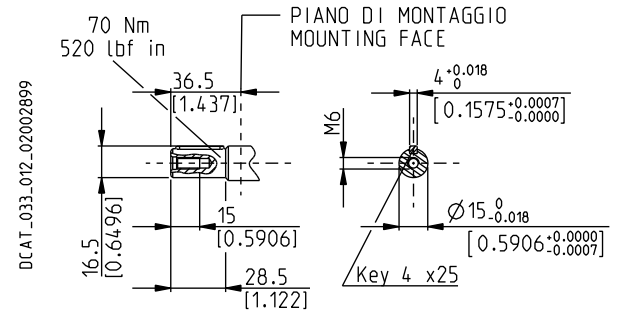

SAE "A" SPLINE

03

Mounting face refer to flange code **S9**

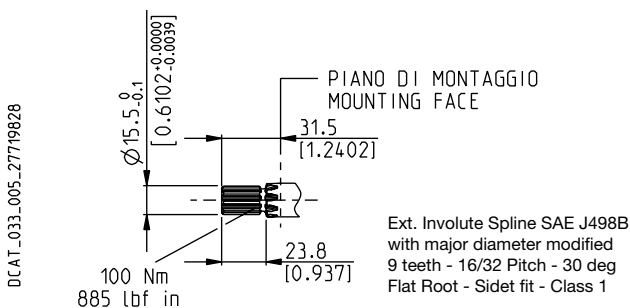

SPLINE

01

Mounting face refer to flange code **S9**

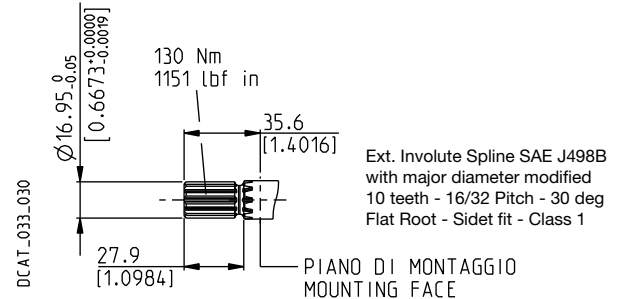

04/01.2019

DRIVE SHAFTS

SAE SPLINE

07

Mounting face refer to flange code **S9**

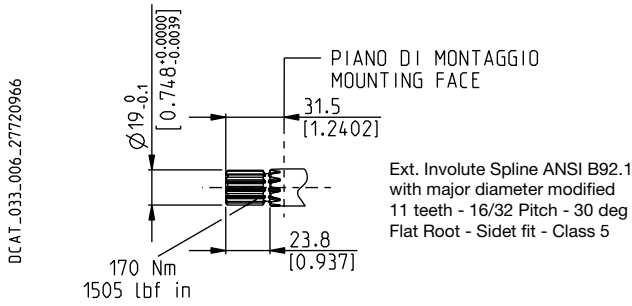

SAE "A" STRAIGHT

31

Not available with size:

20•24,5 - 20•27,8

Mounting face refer to flange code **S9**

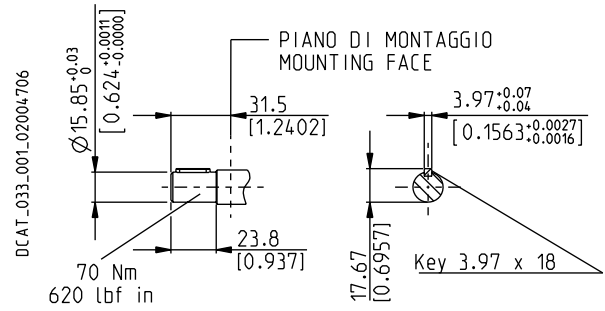

STRAIGHT

49

Not available with size:

20•19 - 20•24,5

Mounting face refer to flange code **S9**

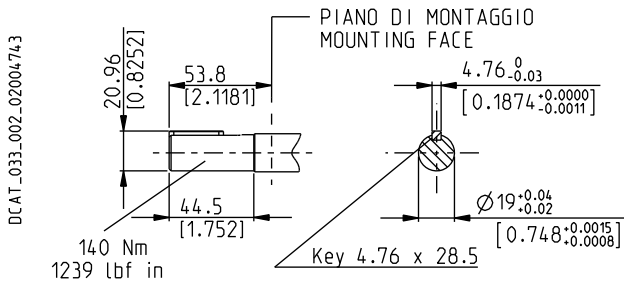

STRAIGHT

50

Mounting face refer to flange code **S9**

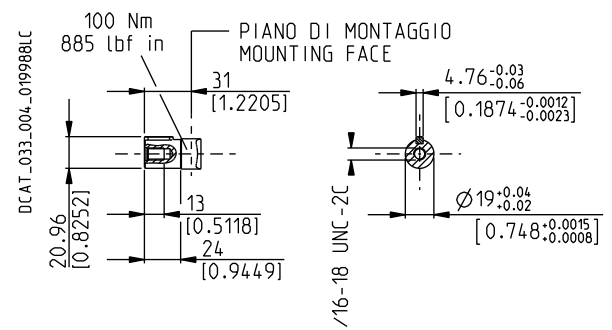

SAE "B" SPLINE

04

Mounting face refer to flange code **S5**

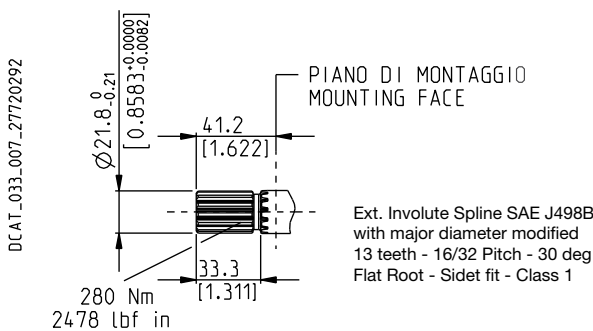

SAE "B" STRAIGHT

32

Not available with size:

20•24,5

Mounting face refer to flange code **S5**

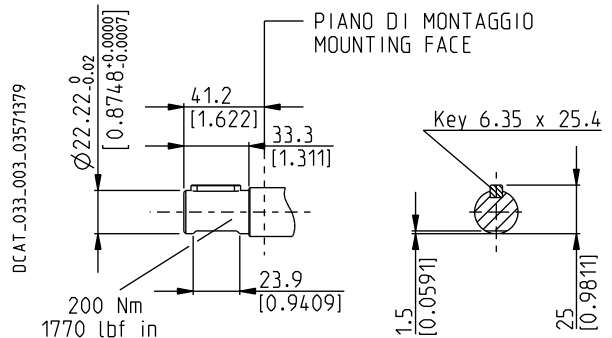

04/01.2019

DRIVE SHAFTS

DIN 5482 SPLINE

12

Mounting face refer to flange code **B2**

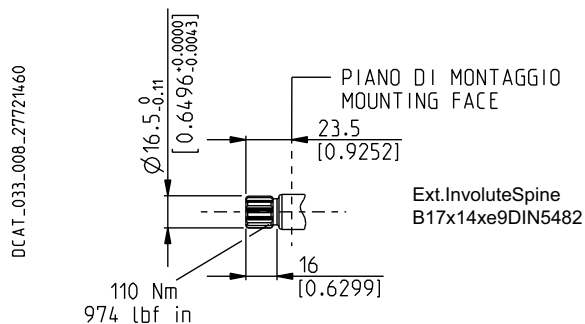

STRAIGHT

48

Only for version **6** with outboard bearing.
Available in **0** version only with size:

20•20

Mounting face refer to flange code **B2**

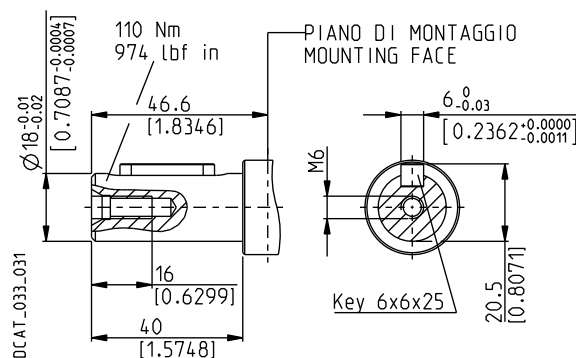

STRAIGHT

B1

Only for version **8** and **5** with outboard bearing.
Mounting face refer to flange code **E2**

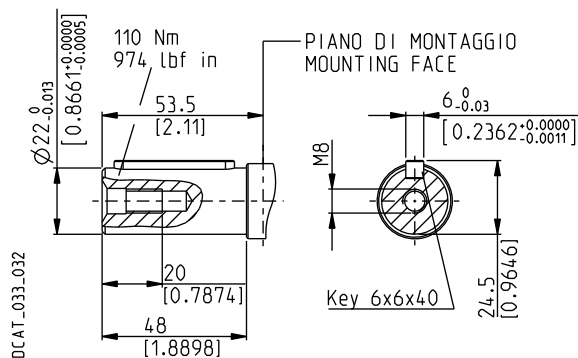

TANG

95

Not available with size:

20•24,5

Mounting face refer to flange code **B6**

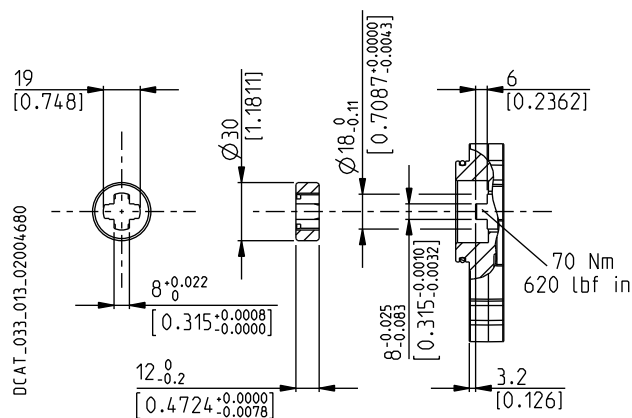

04/01.2019

MOUNTING FLANGES AND TABLE OF COMPATIBILITY

EUROPEAN

E2

Material: cast iron and aluminium

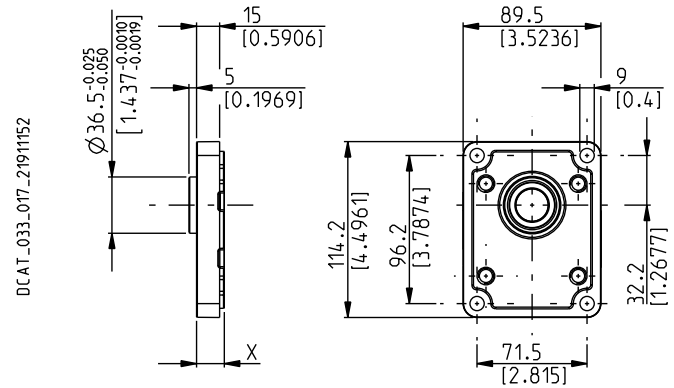

DRIVE SHAFTS See page 31 ÷ 33

VERSIONS See page 26	X mm (in)	82	46	B1	03	04	07	12	31	48	49	50	54
0	18 (0.71)	■	■		●	●	●	●	●	●	●	●	●
4	55,4 (2.18)	■											
5	43,6 (1.72)	■		●	●						●	●	●
6	55,4 (2.18)									■			
7	59,4 (2.34)	■											
8	59,4 (2.34)			■									

- Standard combination
- Available combination

GERMAN

B2

Material: cast iron and aluminium

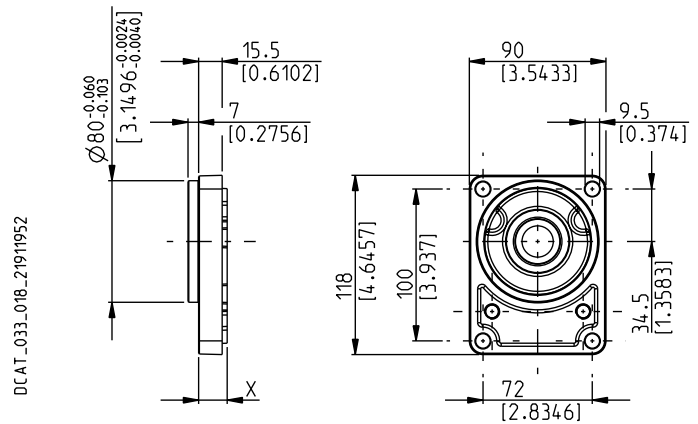

DRIVE SHAFTS See page 31 ÷ 33

VERSIONS See page 26	X mm (in)	12	54	55	01	03	31	46	49	82
0	18,8 (0.74)	■	■		●	●	●	●	●	●
5	44,4 (1.75)		●	●		●			●	●
9	59,4 (2.34)			●						

- Standard combination
- Available combination

01/06.2009

MOUNTING FLANGES AND TABLE OF COMPATIBILITY

GERMAN 2 BOLTS

B4

Material: cast iron and aluminium

⊕ Through hole

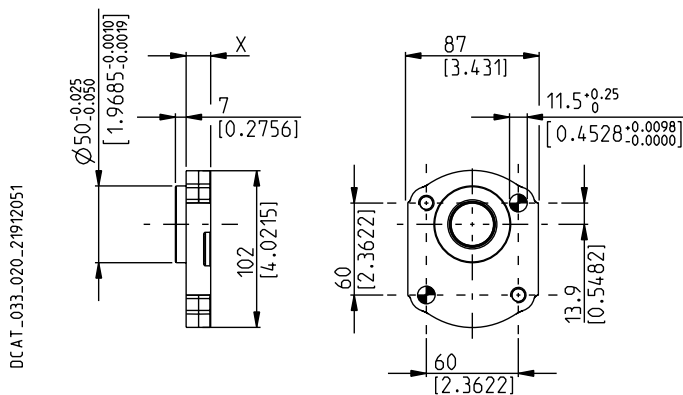

DRIVE SHAFTS

See page 31 ÷ 33

VERSIONS See page 26	X mm (in)	54	03	12	31	49	82
0	16 (0.63)	■	●	●	●	●	●
5	41,6 (1.64)	●	●			●	●

- Standard combination
- Available combination

GERMAN 2 BOLTS

B5

Material: cast iron and aluminium

⊕ Through hole

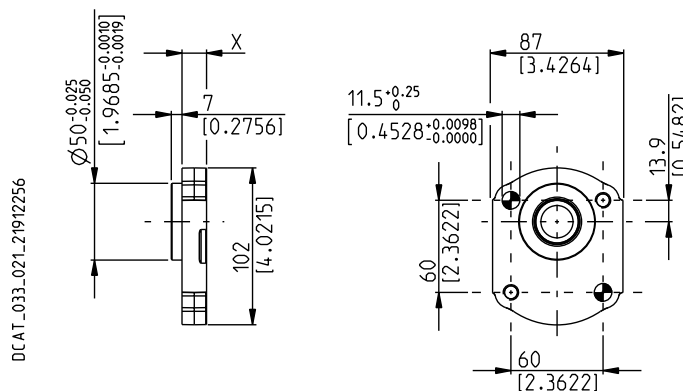

DRIVE SHAFTS

See page 31 ÷ 33

VERSIONS See page 26	X mm (in)	54	03	12	31	49	82
0	16 (0.63)	■	●	●	●	●	●
5	41,6 (1.64)	●	●			●	●

- Standard combination
- Available combination

01/06.2009

MOUNTING FLANGES AND TABLE OF COMPATIBILITY

GERMAN 4 BOLTS

B6

Material: cast iron and aluminium

⊕ Through hole

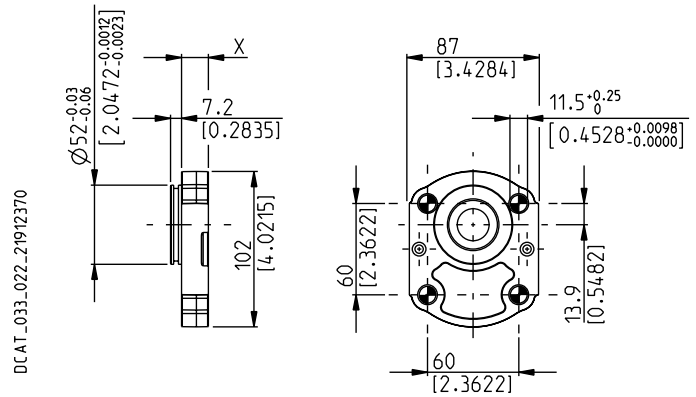

DRIVE SHAFTS See page 32 ÷ 33

VERSIONS See page 26	X mm (in)	95	07	12
0	17,7 (0.70)	■	●	●
5	43,3 (1.70)	●		

- Standard combination
- Available combination

SAE "A" 2 BOLTS

S9

Material: cast iron and aluminium

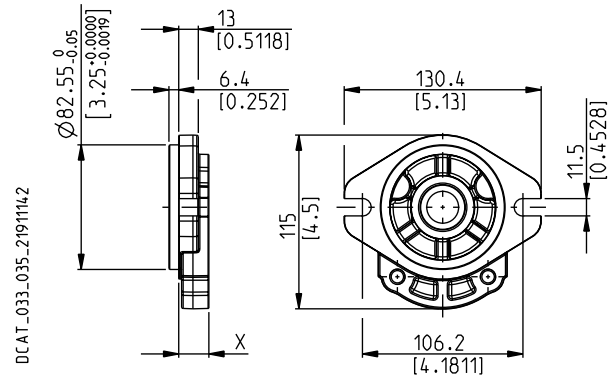

DRIVE SHAFTS See page 31 ÷ 33

VERSIONS See page 26	X mm (in)	01	02	04	07	12	31	32	46	49	50	54	82
0	20 (0.79)	■	■	●	■	●	■	●	●	■	●	●	●
5	45,6 (1.80)		■							●	●	●	●

- Standard combination
- Available combination

01/06.2009

MOUNTING FLANGES AND TABLE OF COMPATIBILITY

SAE "B" 2 BOLTS

S5

Material: cast iron

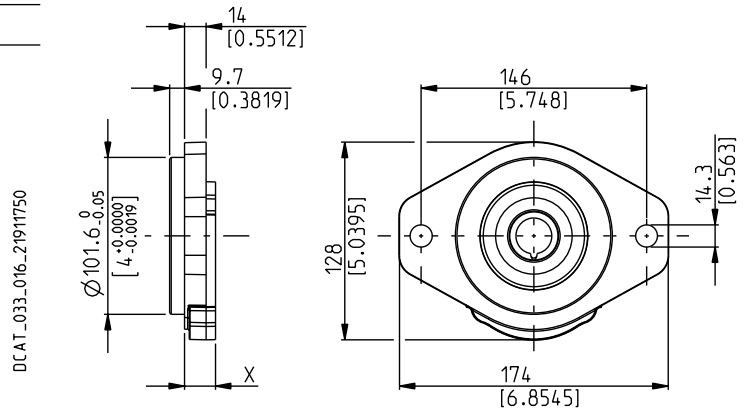

DRIVE SHAFTS See page 32

VERSIONS See page 26	X mm (in)	04	32	49
0	20 (0.79)	■	■	●
5	45,6 (1.80)			●

- Standard combination
- Available combination

GERMAN

W8

Material: cast iron

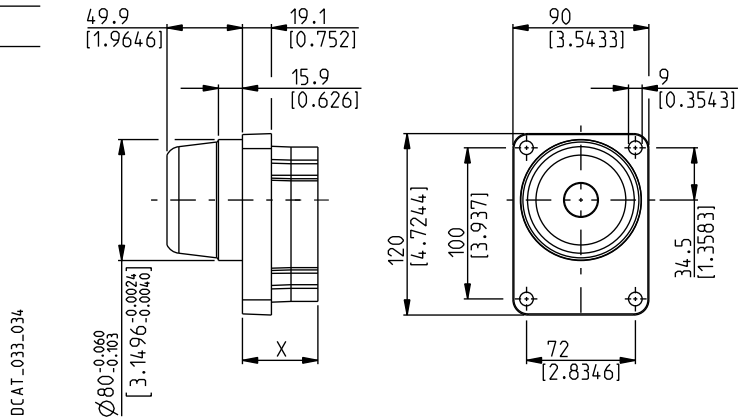

DRIVE SHAFTS See page 31

VERSIONS See page 26	X mm (in)	55
W8	49,8 (1.96)	■

- Standard combination
- Available combination

03/05.2012

PORTS POSITION AND TYPE

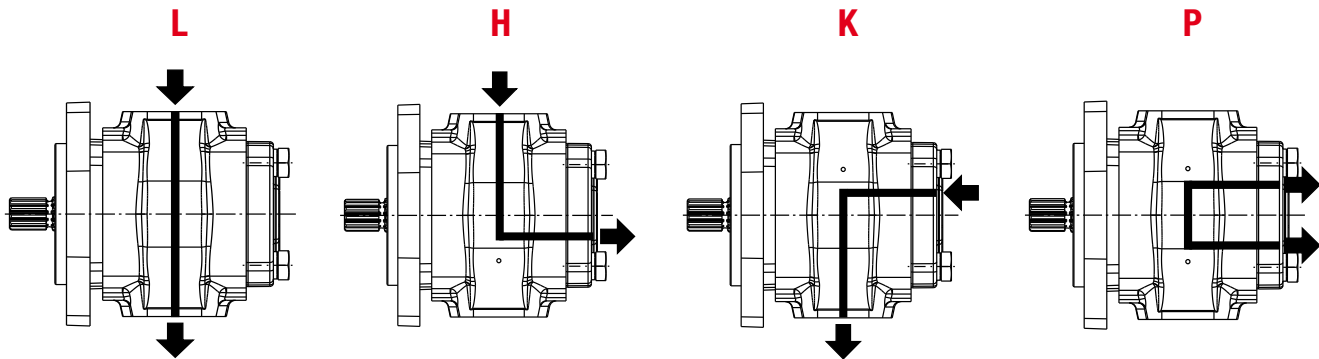

PORTS TYPE	SIDE PORTS												REAR PORTS			
	European		Split SSM		Split SSS		Gas BSPP		SAE ODT		German		Gas BSPP		SAE ODT	
Pump type	IN	OUT	IN	OUT	IN	OUT	IN	OUT	IN	OUT	IN	OUT	IN	OUT	IN	OUT
Motor type	OUT	IN	OUT	IN	OUT	IN	OUT	IN	OUT	IN	OUT	IN	OUT	IN	OUT	IN
PHP 20•8	EA	EA	MA	MA	SA	SA	GD	GD	OC	OC	BE	BC	GD	GD	OC	OC
PHP 20•10,5	EA	EA	MA	MA	SA	SA	GD	GD	OC	OC	BE	BC	GD	GD	OC	OC
PHP 20•11,2	EA	EA	MA	MA	SA	SA	GD	GD	OC	OC	BE	BC	GD	GD	OC	OC
PHP 20•14	EB	EA	MB	MA	SB	SA	GE	GD	OD	OC	BE	BC	GE	GD	OD	OC
PHP 20•16	EB	EA	MB	MA	SB	SA	GE	GD	OD	OC	BE	BC	GE	GD	OD	OC
PHP 20•18	EB	EA	MB	MA	SB	SA	GE	GD	OD	OC	BE	BC	GE	GD	OD	OC
PHP 20•19	EB	EA	MB	MA	SB	SA	GE	GD	OD	OC	BE	BC	GE	GD	OD	OC
PHP 20•20	EB	EA	MB	MA	SB	SA	GE	GD	OD	OC	BE	BC	GE	GD	OD	OC
PHP 20•23	EB	EA	MC	MB	SC	SB	GF	GD	OF	OC	BE	BC	GE	GD	OD	OC
PHP 20•24,5	EB	EA	MC	MB	SC	SB	GF	GD	OF	OC	BE	BC	GE	GD	OD	OC
PHP 20•25	EB	EA	MC	MB	SC	SB	GF	GD	OF	OC	BE	BC	GE	GD	OD	OC
PHP 20•27,8	EB	EA	MC	MB	SC	SB	GF	GD	OF	OC	BE	BC	GE	GD	OD	OC
PHP 20•31,5	EB	EA	MC	MB	SC	SB	GF	GD	OF	OC	BE	BC	GE	GD	OD	OC

Different inlet and outlet ports are available.
Please contact us for more information.

EXTERNAL DRAIN PORTS

IN/OUT PORTS TYPE	SIDE PORTS						REAR PORTS	
	German	European	Split SSM	Split SSS	Gas BSPP	SAE ODT	Gas BSPP	SAE ODT
PHP 20	TA	GB	GB	03	GB	03	GB	03

Dimensions on page 42

04/01.2019

PORT SIZES

 Tightening torque for low pressure side port.



 Tightening torque for high pressure side port.

For reversible rotation, please consult only the tightening torque for high pressure side port.

EUROPEAN FLANGED PORTS - 4 Bolts

EUROPEAN

Metric thread ISO 60° conforms to ISO/R 262

CODE	A	B	C		
	mm (in)	mm (in)	Thread Depth mm (in)	Nm (lbf in)	Nm (lbf in)
EA	13 (0.51)	30 (1.18)	M 6 13 (0.51)	8 ^{+0.5} (71 ÷ 75)	8 ^{+0.5} (71 ÷ 75)
EB	19 (0.75)	40 (1.57)	M 8 14 (0.55)	15 ⁺¹ (133 ÷ 142)	20 ⁺¹ (177 ÷ 186)

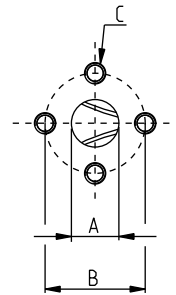

DCAT_006_024_21060533



SAE FLANGED PORTS J518 - Standard pressure series 3000 PSI

SSM

Metric thread ISO 60° conforms to ISO/R 262

CODE	A	B	C	D		
	mm (in)	mm (in)	mm (in)	Thread Depth mm (in)	Nm (lbf in)	Nm (lbf in)
MA	12,5 (0.49)	38,1 (1.50)	17,5 (0.69)	M 8 14 (0.55)	15 ⁺¹ (133 ÷ 142)	15 ⁺¹ (133 ÷ 142)
MB	19 (0.75)	47,6 (1.87)	22,2 (0.87)	M 10 14 (0.55)	20 ⁺¹ (177 ÷ 186)	25 ⁺¹ (266 ÷ 288)
MC	25,4 (1.00)	52,4 (2.06)	26,2 (1.03)	M 10 14 (0.55)	20 ⁺¹ (177 ÷ 186)	25 ⁺¹ (266 ÷ 288)

01/06.2009

DCAT_006_025_21064252

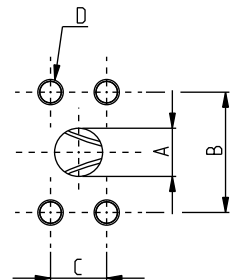

PORT SIZES

 Tightening torque for low pressure side port.



 Tightening torque for high pressure side port.

For reversible rotation, please consult only the tightening torque for high pressure side port.

SAE FLANGED PORTS J518 - Standard pressure series 3000 PSI

SSS

American straight thread UNC-UNF 60° conforms to ANSI B 1.1

CODE	A	B	C	D		
	mm (in)	mm (in)	mm (in)	Thread Depth mm (in)	Nm (lbf in)	Nm (lbf in)
SA	12,5 (0.49)	38,1 (1.50)	17,5 (0.69)	5/16-18 UNC-2B 14 (0.55)	15 ⁺¹ (133 ÷ 142)	20 ⁺¹ (177 ÷ 186)
SB	19 (0.75)	47,6 (1.87)	22,2 (0.87)	3/8 - 16 UNC-2B 14 (0.55)	20 ⁺¹ (177 ÷ 186)	25 ⁺¹ (266 ÷ 288)
SC	25,4 (1.00)	52,4 (2.06)	26,2 (1.03)	3/8 - 16 UNC-2B 14 (0.55)	20 ⁺¹ (177 ÷ 186)	25 ⁺¹ (266 ÷ 288)

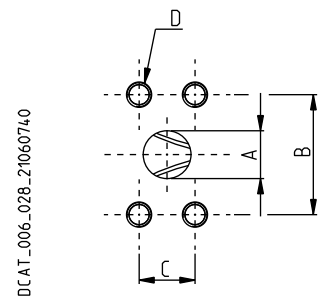



GAS STRAIGHT THREAD PORTS

BSPP

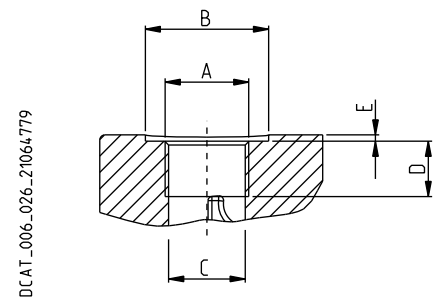
British standard pipe parallel (55°) conforms to UNI - ISO 228



CODE	Nominal size	A	Ø B	Ø C	D	E		
			mm (in)	mm (in)	mm (in)	mm (in)	Nm (lbf in)	Nm (lbf in)
GD	1/2"	G 1/2	—	19 (0.75)	17 (0.67)	—	20 ⁺¹ (177 ÷ 186)	50 ^{+2,5} (443 ÷ 465)
GE	3/4"	G 3/4	—	24,5 (0.96)	18 (0.71)	—	30 ^{+2,5} (266 ÷ 288)	90 ⁺⁵ (797 ÷ 841)
GF	1"	G 1	—	30,5 (1.20)	18 (0.71)	—	50 ^{+2,5} (443 ÷ 465)	130 ⁺¹⁰ (1151 ÷ 1239)

04/01.2019

PORT SIZES

 Tightening torque for low pressure side port.

 Tightening torque for high pressure side port.



For reversible rotation, please consult only the tightening torque for high pressure side port.

SAE STRAIGHT THREAD PORTS J514

ODT

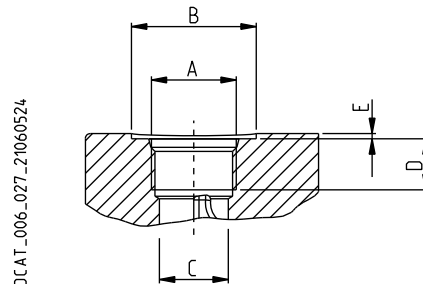
American straight thread UNC-UNF 60° conforms to ANSI B 1.1





CODE	Nominal size	A	Ø B	Ø C	D	E		
			mm (in)	mm (in)	mm (in)	mm (in)	Nm (lbf in)	Nm (lbf in)
OC	5/8"	7/8" - 14 UNF - 2B	35 (1.38)	20,5 (0.81)	17 (0.67)	0,5 (0.02)	30 ^{+2,5} (266 ÷ 288)	70 ⁺⁵ (620 ÷ 664)
OD	3/4"	1 1/16" - 12 UNF - 2B	42 (1.65)	24,8 (0.98)	20 (0.79)	0,5 (0.02)	40 ^{+2,5} (354 ÷ 376)	120 ⁺¹⁰ (1062 ÷ 1151)
OF	1"	1 5/16" - 12 UNF - 2B	49 (1.93)	30,5 (1.20)	20 (0.79)	0,5 (0.02)	60 ⁺⁵ (531 ÷ 575)	170 ⁺¹⁰ (1505 ÷ 1593)

GERMAN FLANGED PORTS - 4 Bolts

GERMAN

Metric thread ISO 60° conforms to ISO/R 262

01/06.2009

CODE	A	B	C		
	mm (in)	mm (in)	Thread Depth mm (in)	Nm (lbf in)	Nm (lbf in)
BC	15 (0.60)	35 (1.38)	M 6 12 (0.47)	8 ^{+0,5} (71 ÷ 75)	8 ^{+0,5} (71 ÷ 75)
BE	20 (0.79)	40 (1.57)	M 6, 12 (0.47)	8 ^{+0,5} (71 ÷ 75)	8 ^{+0,5} (71 ÷ 75)

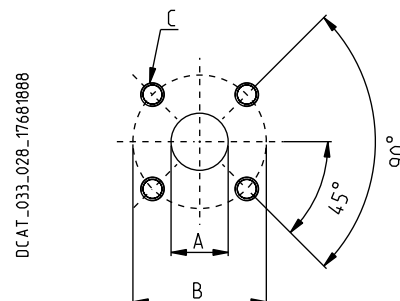

DRAIN PORT SIZES

 Tightening torque for low pressure side port.

GAS STRAIGHT THREAD PORTS

BSPP

British standard pipe parallel (55°) conforms to UNI - ISO 228

DCAT_006_026_21064779

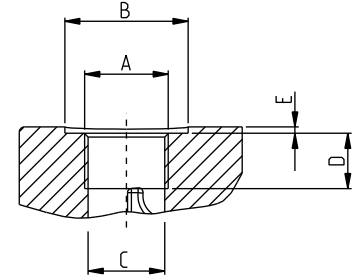

CODE	Nominal size	A	Ø B	Ø C	D	E	
			mm (in)	mm (in)	mm (in)	mm (in)	
GB	1/4"	G 1/4	21,5 (0.85)	12 (0.47)	15 (0.59)	1,5 (0.06)	15 ⁺¹ (133 ÷ 142)

METRIC STRAIGHT THREAD PORTS ISO 6149

METRIC

Metric thread ISO 60° conforms to ISO/R 262

DCAT_006_026_21064779

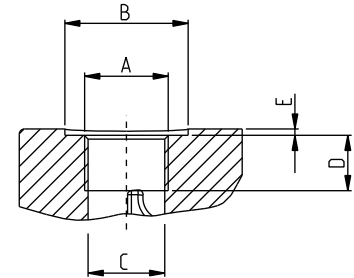

CODE	A	Ø B	Ø C	D	E	
		mm (in)	mm (in)	mm (in)	mm (in)	
TA	M 10x1	22 (0.87)	9 (0.35)	13 (0.51)	0,5 (0.02)	10 ^{+0,5} (89 ÷ 93)

SAE STRAIGHT THREAD PORTS J514

ODT

American straight thread UNC-UNF 60° conforms to ANSI B 1.1

DCAT_006_027_21060524

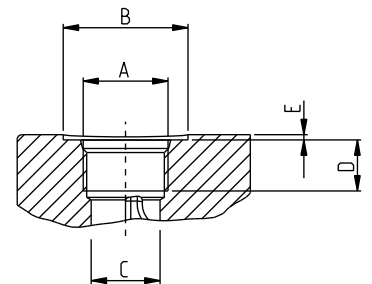

01/06.2009

CODE	A	Ø B	Ø C	D	E	
		mm (in)	mm (in)	mm (in)	mm (in)	
03	7/16"-20 UNF-2B	21 (0.83)	9,5 (0.37)	14 (0.55)	1 (0.04)	12 ⁺¹ (106 ÷ 115)

VALVE OPTIONS

Replaces: 04/01.2019

PRIORITY VALVE

P1

Costant delivery and internal recirculation of excess flow.

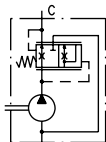

P2

Costant delivery at controlled pressure. Internal recirculation of excess flow and drain valve.

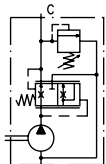

P3

Costant delivery at controlled pressure. Excess flow and drain valve must be connected to tank.

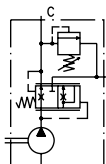

P4

Costant delivery and excess flow can both be used under load.

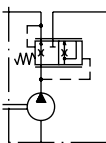

P5T

Costant delivery at controlled pressure with drain valve connected to tank. Excess flow can be used under load.

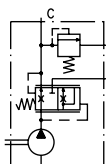

ELECTRIC VALVE

○

UNL...

By-pass valve with anti-cavitation valve.

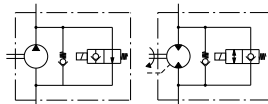

○

PRV...

Proportional relief valve.

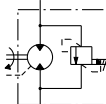

○ 05/05.2023

MAX PRESSURE RELIEF VALVE

VPEF...

Fixed setting with external drain.

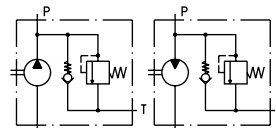

VPIF...

Fixed setting with internal drain.

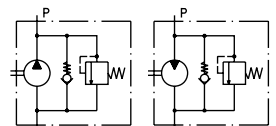

VPER...

Adjustable setting with external drain.

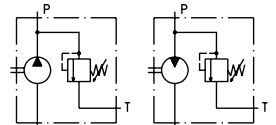

VPIR...

Adjustable setting with internal drain.

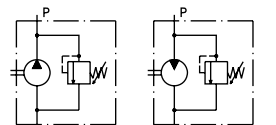

LOAD SENSING VALVE

...

Static.

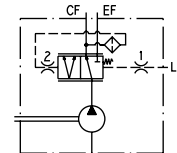

...

Dynamic.

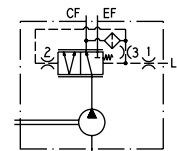

...

Dynamic with relief valve fitted on the main line.

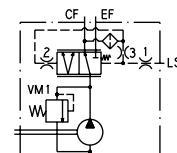

...

Dynamic with relief valve fitted on controlled line.

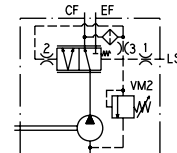

CHECK VALVE

V8

Anti-cavitation valve.

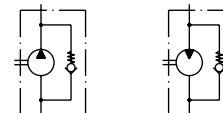

For more information please refer to our built-in valves and fan drive technical catalogues.

HOW TO ORDER - SINGLE UNITS

1	2	3	4	5	6	7	8	9	10	11	12	13							
PHP 20•19	L	0	-	82	E2	-	L	EB/EA	-	N	-	EL	-	D	-	*	GB	-	FS

1	Type	Pump type	Motor type
	8,26 cm ³ /rev (0.50 in ³ /rev)	PHP 20•8	PHM 20•8
	10,9 cm ³ /rev (0.66 in ³ /rev)	PHP 20•10,5	PHM 20•10,5
	11,23 cm ³ /rev (0.69 in ³ /rev)	PHP 20•11,2	PHM 20•11,2
	14,53 cm ³ /rev (0.89 in ³ /rev)	PHP 20•14	PHM 20•14
	16,85 cm ³ /rev (1.03 in ³ /rev)	PHP 20•16	PHM 20•16
	18,29 cm ³ /rev (1.12 in ³ /rev)	PHP 20•18	PHM 20•18
	19,09 cm ³ /rev (1.16 in ³ /rev)	PHP 20•19	PHM 20•19
	21,14 cm ³ /rev (1.29 in ³ /rev)	PHP 20•20	PHM 20•20
	23,32 cm ³ /rev (1.42 in ³ /rev)	PHP 20•23	PHM 20•23
	24,84 cm ³ /rev (1.52 in ³ /rev)	PHP 20•24,5	PHM 20•24,5
	26,42 cm ³ /rev (1.61 in ³ /rev)	PHP 20•25	PHM 20•25
	28,21 cm ³ /rev (1.72 in ³ /rev)	PHP 20•27,8	PHM 20•27,8
	33,03 cm ³ /rev (2.01 in ³ /rev)	PHP 20•31,5	PHM 20•31,5

2	Rotation	Code
	Left	S
	Right	D
	Reversible rear external drain	R
	Reversible side external drain	L
	Reversible internal drain	B

3	Outboard bearing options	Code
	Without outboard bearing	0
	Version	W8
	Version	4
	Version	5
	Version	6
	Version	7
	Version	8
	Version	9

4	Drive shaft	Code
	European tapered 1:8	82
	German tapered 1:5	54
	German tapered 1:5	55
	Straight	46
	SAE "A" spline (9 teeth)	03
	SAE spline (10 teeth)	01
	SAE "A" spline (11 teeth)	07
	SAE "A" straight	31
	Straight	49
	Straight	50

Code	Drive shaft	4
04	SAE "B" spline	
32	SAE "B" straight	
12	DIN 54 82 spline	
48	Straight (only for version 6)	
B1	Straight (only for version 8)	
95	Tang	

Code	Mounting flange	5
E2	European	
B2	German	
B4	German 2 bolt	
B5	German 2 bolt	
B6	German 4 bolt	
S9	SAE "A" 2 bolt	
S5	SAE "B" 2 bolt	
W8	German	

Code	Ports position	6
L	IN/OUT side	
H	IN side / OUT rear	
K	IN rear / OUT side	
P	Rear	

Code	Ports IN/OUT	7
GERMAN FLANGED PORTS		
Side	Rear	Type
BE/BC	PHP 20	8-10,5-11,2,14-16-18-19-20-23-24,5
BC/BE	PHM 20	25-27,8-31,5
EUROPEAN FLANGED PORTS		
Side	Rear	Type
EA/EA	PHP 20	8-10,5-11,2
EA/EA	PHM 20	
EB/EA	PHP 20	14-16-18-19-20
EA/EB	PHM 20	23-24,5-25-27,8-31,5
SAE FLANGED PORTS (SSM)		
Side	Rear	Type
MA/MA	PHP 20	8-10,5-11,2
MA/MA	PHM 20	
MB/MA	PHP 20	14-16-18-19-20
MA/MB	PHM 20	
MC/MB	PHP 20	23-24,5-25-27,8-31,5
MB/MC	PHM 20	

04/01.2019

HOW TO ORDER - SINGLE UNITS

7	Ports IN/OUT	Code
----------	---------------------	------

SAE FLANGED PORTS (SSS)		
--------------------------------	--	--

Type	Side	Rear
8-10,5-11,2	PHP 20	SA/SA
	PHM 20	SA/SA
14-16-18-19-20	PHP 20	SB/SA
	PHM 20	SA/SB
23-24,5-25-27,8-31,5	PHP 20	SC/SB
	PHM 20	SB/SC

GAS STRAIGHT THREAD PORTS (BSPP)		
---	--	--

Type	Side	Rear
8-10,5-11,2	PHP 20	GD/GD GD/GD
	PHM 20	GD/GD GD/GD
14-16-18-19-20	PHP 20	GE/GD GE/GD
	PHM 20	GD/GE GD/GE
23-24,5-25-27,8-31,5	PHP 20	GF/GD GE/GD
	PHM 20	GD/GF GD/GF

SAE STRAIGHT THREAD PORTS (ODT)		
--	--	--

Type	Side	Rear
8-10,5-11,2	PHP 20	OC/OC OC/OC
	PHM 20	OC/OC OC/OC
14-16-18-19-20	PHP 20	OD/OC OD/OC
	PHM 20	OC/OD OC/OD
23-24,5-25-27,8-31,5	PHP 20	OF/OC OD/OC
	PHM 20	OC/OF OC/OD

8	Seals (a)	Code
----------	------------------	------

Buna (standard)	N
Viton	V
Hydrogenated buna HNBR seals with Viton-FKM shaft seals	T-PV

9	Mounting flange and rear cover options (b)	Code
----------	---	------

Cast iron mounting flange and rear cover (standard - no code)	E
Aluminium mounting flange and cast iron rear cover	L
Cast iron mounting flange and aluminium rear cover	EL

10	Shaft seal options	Code
-----------	---------------------------	------

Standard shaft seal with wiper seal	D
High pressure special shaft seal	H
High pressure special shaft seal with wiper seal	C

Code	Drain port position - Rev. rotation L	11
------	--	----

L	Side drain with side port position
*	Side drain with bottom port position

Code	Drain port	12
------	-------------------	----

IN/OUT GERMAN FLANGED PORTS		
------------------------------------	--	--

Side	Rear	Type
TA	PHP 20	8-10,5-11,2,14-16-18-19-20-23-24,5
	PHM 20	25-27,8-31,5

IN/OUT EUROPEAN FLANGED PORTS		
--------------------------------------	--	--

Side	Rear	Type
GB	PHP 20	8-10,5-11,2,14-16-18-19-20-23-24,5
	PHM 20	25-27,8-31,5

IN/OUT SAE FLANGED PORTS (SSM)		
---------------------------------------	--	--

Side	Rear	Type
GB	PHP 20	8-10,5-11,2,14-16-18-19-20-23-24,5
	PHM 20	25-27,8-31,5

IN/OUT SAE FLANGED PORTS (SSS)		
---------------------------------------	--	--

Side	Rear	Type
03	PHP 20	8-10,5-11,2,14-16-18-19-20-23-24,5
	PHM 20	25-27,8-31,5

IN/OUT GAS STRAIGHT THREAD PORTS (BSPP)		
--	--	--

Side	Rear	Type
GB	PHP 20	8-10,5-11,2,14-16-18-19-20-23-24,5
	PHM 20	25-27,8-31,5

IN/OUT SAE STRAIGHT THREAD PORTS (ODT)		
---	--	--

Side	Rear	Type
03	PHP 20	8-10,5-11,2,14-16-18-19-20-23-24,5
	PHM 20	25-27,8-31,5

Code	Shaft arrangement	13
------	--------------------------	----

FS	Female spline
-----------	---------------

- (a) Choose the seals according to the temperature shown on page 5
- (b) Mounting flange material on page 34 ÷ 37
Rear cover material on page 18 ÷ 19

04/01.2019

HOW TO ORDER - POLARIS PHP 20 DOUBLE PUMPS

1	2	3	4	5	6	7	8	9	10	11	12					
PHP 20•19	-	82	E2	-	L	EB/EA	/									
Front section																
20•19	-		L	**/EA	-	S7	-	S	/	FS	-	L	-	N	-	C
Rear section																

1	Type	Pump type
8,26 cm ³ /rev (0.50 in ³ /rev)		PHP 20•8
10,9 cm ³ /rev (0.66 in ³ /rev)		PHP 20•10,5
11,23 cm ³ /rev (0.69 in ³ /rev)		PHP 20•11,2
14,53 cm ³ /rev (0.89 in ³ /rev)		PHP 20•14
16,85 cm ³ /rev (1.03 in ³ /rev)		PHP 20•16
18,29 cm ³ /rev (1.12 in ³ /rev)		PHP 20•18
19,09 cm ³ /rev (1.16 in ³ /rev)		PHP 20•19
21,14 cm ³ /rev (1.29 in ³ /rev)		PHP 20•20
23,32 cm ³ /rev (1.42 in ³ /rev)		PHP 20•23
24,84 cm ³ /rev (1.52 in ³ /rev)		PHP 20•24,5
26,42 cm ³ /rev (1.61 in ³ /rev)		PHP 20•25
28,21 cm ³ /rev (1.72 in ³ /rev)		PHP 20•27,8
33,03 cm ³ /rev (2.01 in ³ /rev)		PHP 20•31,5

2	Drive shaft	Code
European tapered 1:8		82
German tapered 1:5		54
German tapered 1:5		55
Straight		46
SAE "A" spline (9 teeth)		03
SAE spline (10 teeth)		01
SAE "A" spline (11 teeth)		07
SAE "A" straight		31
Straight		49
Straight		50
SAE "B" spline		04
SAE "B" straight		32
DIN 54 82 spline		12
Straight (only for version 6)		48
Straight (only for version 8)		B1
Tang		95

3	Mounting flange	Code
European		E2
German		B2
German 2 bolt		B4
German 2 bolt		B5

Code	Mounting flange	3
B6	German 4 bolt	
S9	SAE "A" 2 bolt	
S5	SAE "B" 2 bolt	
W8	German	

Code	Ports position	4
L	Side	

Code	Ports IN/OUT	5
GERMAN FLANGED PORTS		
Side	Type	
BE/BC	PHP 20	8-10,5-11,2-14-16-18-19 20-23-24,5-25-27,8-31,5

Code	Ports IN/OUT	5
EUROPEAN FLANGED PORTS		
Side	Type	
EA/EA	PHP 20	8-10,5-11,2
EB/EA	PHP 20	14-16-18-19-20-23-24,5 25-27,8-31,5

Code	Ports IN/OUT	5
SAE FLANGED PORTS (SSM)		
Side	Type	
MA/MA	PHP 20	8-10,5-11,2
MB/MA	PHP 20	14-16-18-19-20
MC/MB	PHP 20	23-24,5-25-27,8-31,5

Code	Ports IN/OUT	5
SAE FLANGED PORTS (SSS)		
Side	Type	
SA/SA	PHP 20	8-10,5-11,2
SB/SA	PHP 20	14-16-18-19-20
SC/SB	PHP 20	23-24,5-25-27,8-31,5

Code	Ports IN/OUT	5
GAS STRAIGHT THREAD PORTS (BSPP)		
Side	Type	
GD/GD	PHP 20	8-10,5-11,2
GE/GD	PHP 20	14-16-18-19-20
GF/GD	PHP 20	23-24,5-25-27,8-31,5

Code	Ports IN/OUT	5
SAE STRAIGHT THEREAD PORTS (ODT)		
Side	Type	
OC/OC	PHP 20	8-10,5-11,2
OD/OC	PHP 20	14-16-18-19-20
OF/OC	PHP 20	23-24,5-25-27,8-31,5

04/01.2019

HOW TO ORDER - POLARIS PHP 20 DOUBLE PUMPS

6	Combination type	Code
	Standard	S6
	Common inlet	S7
	Separate stages	Z6

7	Rotation	Code
	Left	S
	Right	D

8	Outboard bearing options	Code
	Without outboard bearing (standard) no code	...
	Version	W8
	Version	4
	Version	5
	Version	6
	Version	7
	Version	8
	Version	9

Code	Shaft arrangement	9
FS	Female spline	

Code	Mounting flange and rear cover options (a)	10
	Cast iron mounting flange and rear cover (standard) - no code	
L	Cast iron mounting flange and aluminium rear cover	

Code	Seals (b)	11
N	Buna (standard)	
V	Viton	
T-PV	Hydrogenated buna HNBR seals with Viton-FKM shaft seals	

Code	Shaft seal options	12
D	Standard shaft seal with wiper seal	
H	High pressure special shaft seal	
C	High pressure special shaft seal with wiper seal	

- (a) Mounting flange material on page 34 ÷ 37
Rear cover material on page 24
- (b) Choose the seals according to the temperature shown on page 5

HOW TO ORDER - POLARIS PHP 20 DOUBLE PUMPS DIFFERENT GROUPS

PHP 20/PLP 20

1	2	3	4	5	6	7	8	9	10	11	12				
PHP 20•19	-	82	E2	-	L	EB/EA	/								
Front section															
PLP 20•4	-		L	EA/EA	-	S	O	/	FS	-	L	-	N	-	C
Rear section															

PHP 20/PLP 10

1	2	3	4	5	6	7	8	9	10	11	12				
PHP 20•19	-	82	E2	-	L	EB/EA	/								
Front section															
PLP 10•1	-		L	BB/BA	-	S	O	/	FS	-	L	-	N	-	C
Rear section															

1	Type (a)	Code
	The same of double pumps PHP 20/20	PHP..
2	Drive shaft	Code
	The same of double pumps PHP 20/20	...
3	Mounting flange	Code
	The same of double pumps PHP 20/20	...
4	Ports position	Code
	Side	L
5	Ports IN/OUT	Code
	The same of double pumps PHP 20/20	../.
6	Combination type	Code
	PHP 20/PLP 20 Standard - No code	S6
	PHP 20/PLP 20 Common inlet	S7
	PHP 20/PLP 20 Separate stages	Z6
	PHP 20/PLP 10 Standard - No code	T6
	PHP 20/PLP 10 Common inlet	T7
	PHP 20/PLP 10 Separate stages	Z6
7	Rotation	Code
	The same of double pumps PHP 20/20	...

Code	Outboard bearing options	8
...	The same of double pumps	
Code	Shaft arrangement	9
FS	Female spline	
Code	Mounting flange and rear cover options (b)	10
	Cast iron mounting flange and rear cover (standard) - no code	
E	Aluminium mounting flange and cast iron rear cover	
L	Cast iron mounting flange and aluminium rear cover	
EL	Aluminium mounting flange and rear cover	
Code	Seals	11
...	The same of double pumps PHP 20/20	
Code	Shaft seal options	12
...	The same of double pumps PHP 20/20	

- (a) For PLP 20 and PLP 10 features please consult the proper technical catalogue
- (b) Mounting flange material on page 34 ÷ 37
Rear cover material on page 24 ÷ 25

04/01.2019

NOTES

04/01.2019

NOTES

04/01.2019

Our policy is one of continuous improvement in product. Specification of items may, therefore, be changed without notice.

PH 05 T A

Edition: 05/05.2023

Replaces: PH 04 T A



Headquarters:

CASAPPA S.p.A.

Via Balestrieri, 1

43044 Lemignano di Collecchio

Parma (Italy)

Tel. (+39) 0521 30 41 11

Fax (+39) 0521 80 46 00

E-mail: info@casappa.com

www.casappa.com

