

# Internal gear pump, fixed displacement

**RE 10213/04.05**  
Replaces: 06.02

1/24

## Type PGF

Frame sizes 1, 2 and 3

Component series: 2X (FS1 and 2)  
3X (FS3)Maximum operating pressure 250 bar  
Maximum displacement 1.7 to 40 cm<sup>3</sup>

H7158

Type PGF1... for direct mounting



H7163

Type PGF3... 3-fold combination

## Table of contents

Contents	Page
Features	1
Ordering code	2
Function, section, symbol	3
Technical data	4 and 5
Characteristic curves	6 to 8
Unit dimensions	9 to 17
Suction and pressure ports	18 and 19
Multiple pumps	20
Installation notes	21
Commissioning notes	22
Engineering notes	23

## Features

- Fixed displacement
- Low operating noise
- Low flow pulsation
- High efficiency even at low viscosity due to sealing gap compensation
- Long service life due to plain bearings and sealing gap compensation
- Suitable for a wide viscosity and speed range
- Excellent suction characteristics
- All frame sizes and sizes can be combined with each other
- Can be combined with PGH internal gear pumps, PV7 vane pumps and axial piston pumps
- Valve technology can be integrated in the cover plate on enquiry

### Ordering code

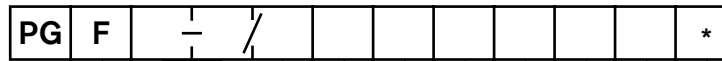

**Series**

Medium-pressure pump = F

**Frame size - component series**

FS1 – component series 2X = 1-2X  
(component series 20 to 29: unchanged installation and connection dimensions)

FS2 – component series 2X = 2-2X  
(component series 20 to 29: unchanged installation and connection dimensions)

FS3 – component series 3X = 3-3X  
(component series 30 to 39: unchanged installation and connection dimensions)

Size	Size	Displacement/ revolution	
FS1	1.7	1.7 cm <sup>3</sup>	= 1,7
	2.2	2.2 cm <sup>3</sup>	= 2,2
	2.8	2.8 cm <sup>3</sup>	= 2,8
	3.2	3.2 cm <sup>3</sup>	= 3,2
	4.1	4.1 cm <sup>3</sup>	= 4,1
FS2	5.0	5.0 cm <sup>3</sup>	= 5,0
	6.3	6.5 cm <sup>3</sup>	= 006
	8.0	8.2 cm <sup>3</sup>	= 008
	11.0	11.0 cm <sup>3</sup>	= 011
	13.0	13.3 cm <sup>3</sup>	= 013
	16.0	16.0 cm <sup>3</sup>	= 016
FS3	19.0	18.9 cm <sup>3</sup>	= 019
	22.0	22.0 cm <sup>3</sup>	= 022
	25.0	25.4 cm <sup>3</sup>	= 025
	32.0	32.5 cm <sup>3</sup>	= 032
	40.0	40.5 cm <sup>3</sup>	= 040

Order example: PGF2-2X/011RE01VE4

Material-Number: R900932271

Not all of the variants according to the type code are possible! Please select the requested pump on the basis of the selection table (preferred types, pages 9 to 17) or consult Bosch Rexroth!

Special options on enquiry (e.g. integrated valve technology).

Further details in clear text

**Options**

- N = Anti-cavitation valve
- D = Pressure relief valve
- K = Cover plate for mounting the next smaller size

**Mounting flange centring**

- K4 = Special flange to ISO 7653-1985 (for truck PTO)
- E4 = 4-hole mounting flange to ISO 3019/2 and VDMA 24560 part 1
- U2 = SAE 2-hole mounting flange
- M = 2-hole mounting, centring Ø 32 mm (FS1), centring Ø 52 mm (FS2 and 3)
- P = 2 hole mounting, centring Ø 50 mm
- P1 = 2-hole mounting, centring Ø 45.24 mm
- P2 = 2-hole mounting, centring Ø 63 mm

**Seal material**

- V = FKM seals
- Please observe our regulations to data sheet RE 07075!**

**Suction and pressure port**

- 01 = BSP to ISO 228/1
- 07 = SAE flange connection
- 20 = Square flange connection to DIN 3901 or DIN 3902, metric mounting thread

**Shaft versions**

- A = Cylindrical
- E = Cylindrical with output
- T = Involute splines
- J = Involute splines with output
- N = Two flats for claw coupling
- L = Two flats for claw coupling with output
- S = Conical 1 : 5
- O = Conical with output 1 : 5

**Direction of rotation (viewed to shaft end)**

- R = Clockwise
- L = Counter-clockwise

Function, section, symbol

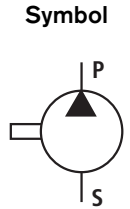
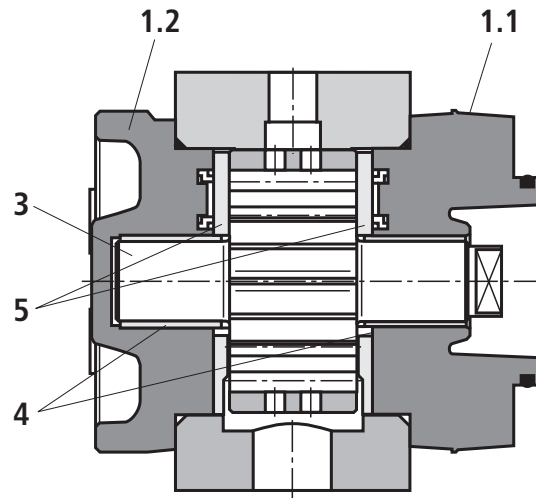
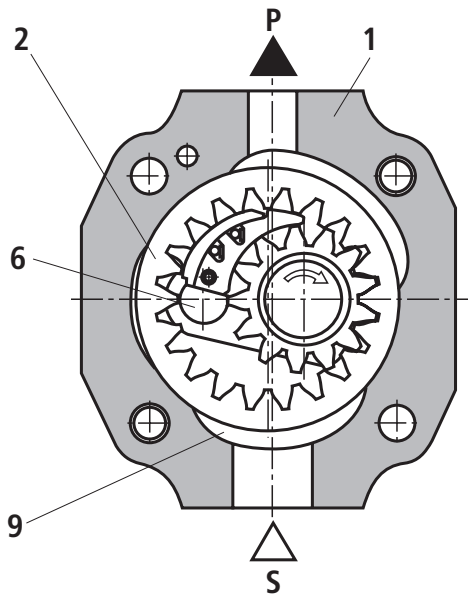

**Design**

PGF hydraulic pumps are leak gap-compensated internal gear pumps with a fixed displacement.

They basically consist of a housing (1), bearing cover (1.1), cover plate (1.2), internal gear (2), pinion shaft (3), plain bearings (4), axial discs (5) and stop pin (6) as well as the segment assembly (7), which is composed of a segment (7.1), segment carrier (7.2) and the sealing rolls (7.3).

**Suction and displacement process**

The pinion (3) which is carried in hydro-dynamic bearings drives the internally toothed ring gear (2) in the direction of rotation shown.

During rotation, the volume is increased in the suction area at an angle of approx. 180°. A negative pressure is generated and fluid flows into the chambers.

The sickle-shaped segment assembly (7) separates the suction chamber from the pressure chamber. Within the pressure chamber the teeth of the pinion (3) mesh with the tooth spaces of the internal gear (2). The fluid is then displaced through the pressure channel (P).

**Axial compensation**

Axial compensation force  $F_A$  acts in the area of the pressure chamber and is generated by the pressure field (8) in the axial discs (5).

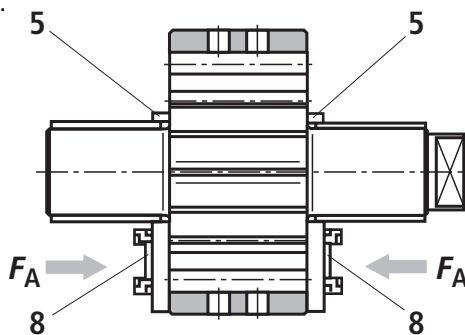

The axial longitudinal gaps between rotating and fixed parts are therefore extremely small and ensure optimum axial sealing of the pressure chamber.

**Radial compensation**

Radial compensation force  $F_R$  acts on the segment (7.1) and segment carrier (7.2).

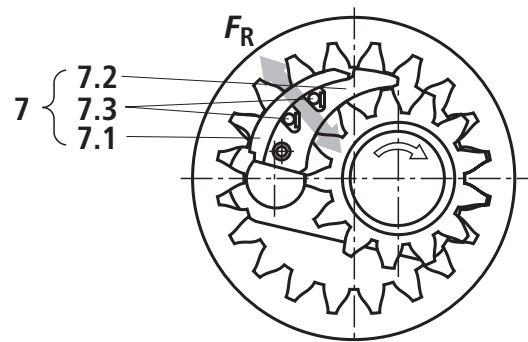

The area ratios and the position of the sealing rolls (7.3) between the segments and the segment carrier are designed to provide virtually leak gap-free sealing between the internal gear (2), the segment assembly (7) and the pinion (3).

Spring elements under the sealing rolls (7.3) ensure adequate contact pressure, even at very low pressures.

**Hydrodynamic and hydrostatic bearing**

The forces acting on the pinion shaft (3) are absorbed by the hydrodynamically lubricated radial plain bearings (4), while those acting on the internal gear (2) are absorbed by the hydrostatic bearing (9).

**Tooth form**

Involute teeth were selected for the gear. Their long length of contact results in low flow and pressure pulsation; these low pulsation rates greatly contribute to low-noise operation.

**Technical data** (for applications outside these parameters, please consult us!)**General**

Design	Internal gear pump, gap-compensated
Type	PGF
Mounting type	2-hole mounting, SAE 2-hole mounting flange to ISO 3019/1, 4-hole mounting to VDMA 24560 part 1 and ISO 3019/2
Pipe connections	Square flange connection; SAE flange connection; BSP to ISO 228/1
Installation orientation	Optional
Shaft loading	Radial and axial forces (e.g. pulley) <b>only</b> after consultation
Direction of rotation (viewed to shaft end)	Clockwise or counter-clockwise – <b>not</b> reversing!

**Frame size****FS1**

Size	Size	1.7	2.2	2.8	3.2	4.1	5.0
Weight	$m$ kg	0.8	0.9	1.0	1.0	1.1	1.3
Speed range <sup>1)</sup>	$n_{min}$ min <sup>-1</sup>	600					
	$n_{max}$ min <sup>-1</sup>	4500	3600	4000	3600	3600	3600
Displacement	$V$ cm <sup>3</sup>	1.7	2.2	2.8	3.2	4.1	5.0
Flow <sup>2)</sup>	$q_V$ L/min	2.4	3.2	4.1	4.6	6.0	7.2
Operating pressure, absolute – Inlet	$p$ bar	0.8 to 2					
– Output, continuous	$p_{max}$ bar	180	210	210	210	210	180
– Output, intermittent <sup>3)</sup>	$p_{max}$ bar	210	250	250	250	250	210
Min. required drive power at $\Delta p = 0$ bar	kW	0.75	0.75	0.75	0.75	0.75	0.75

**Frame size****FS2**

Size	Size	6.3	8	11	13	16	19	22
Weight <sup>4)</sup>	$m$ kg	2.1	2.2	2.4	2.6	2.7	2.9	3.1
Speed range <sup>1)</sup>	$n_{min}$ min <sup>-1</sup>	600						600
	$n_{max}$ min <sup>-1</sup>	3600						3000
Displacement	$V$ cm <sup>3</sup>	6.5	8.2	11	13.3	16	18.9	22
Flow <sup>2)</sup>	$q_V$ L/min	9.4	11.9	16	19.3	23.2	27.4	31.9
Operating pressure, absolute – Inlet	$p$ bar	0.6 to 3						
– Output, continuous	$p_{max}$ bar	210	210	210	210	210	210	180
– Output, intermittent <sup>3)</sup>	$p_{max}$ bar	250	250	250	250	250	250	210
Min. required drive power at $\Delta p = 0$ bar	kW	0.75	0.75	0.75	0.75	0.75	1.1	1.1

For footnotes, see page 5

**Technical data** (for applications outside these parameters, please consult us!)

Frame size		FS3				
Size	Size	20	22	25	32	40
Weight <sup>4)</sup>	<i>m</i> kg	3.3	3.7	4.1	4.5	4.9
Speed range <sup>1)</sup>	<i>n</i> <sub>min</sub> min <sup>-1</sup>	500				
	<i>n</i> <sub>max</sub> min <sup>-1</sup>	3600	3400	3200	3000	2500
Displacement	<i>V</i> cm <sup>3</sup>	20.6	22.2	25.4	32.5	40.5
Flow <sup>2)</sup>	<i>q<sub>V</sub></i> L/min	29.9	32.2	36.8	47.1	58.7
Operating pressure, absolute		0.6 to 3				
– Inlet	<i>p</i> bar	0.6 to 3				
– Outlet, continuous	<i>p</i> <sub>max</sub> bar	210	210	210	210	180
– Outlet, intermittent <sup>3)</sup>	<i>p</i> <sub>max</sub> bar	250	250	250	250	210
Min. required drive power at $\Delta p = 0$ bar		1.1	1.1	1.5	1.5	2.2

**Hydraulic**

Hydraulic fluid <sup>5)</sup>	HL mineral oil to DIN 51524 part 1 / HLP - mineral oil to DIN 51524 part 2 <b>Please note our regulations according to data sheet RE 07075!</b>
Hydraulic fluid temperature range	°C – 20 to + 100; for other temperatures, please consult us!
Ambient temperature range	°C – 20 to + 60
Viscosity range	mm <sup>2</sup> /s 10 to 300; permissible starting viscosity 2000
Max. permissible degree of contamination of the hydraulic fluid Cleanliness class to ISO 4406 (c)	Class 20/18/15 <sup>6)</sup>
Permissible radial loading of the pinion shaft	On enquiry

<sup>1)</sup> In the case of other speeds, please consult us (e.g. impulse control)

<sup>2)</sup> Measured at  $n = 1450$  min<sup>-1</sup> and  $p = 10$  bar

<sup>3)</sup> Max 6 s, not exceeding 15 % of the duty cycle, max.  $2 \cdot 10^6$  load cycles

<sup>4)</sup> For pumps with 2-hole mounting as flanged version  
– Frame size 2 approx. 0.9 kg heavier  
– Frame size 3 approx. 1.0 kg heavier

<sup>5)</sup> Other fluids on enquiry

<sup>6)</sup> The cleanliness classes specified for components must be adhered to in hydraulic systems. Effective filtration prevents malfunction and at the same time prolongs the service life of components.

For the selection of filters, see data sheets RE 50070, RE 50076, RE 50081, RE 50086 and RE 50088.

**Average characteristic curve values of frame size 1 (measured at  $n = 1450 \text{ min}^{-1}$ ;  $v = 46 \text{ mm}^2/\text{s}$  and  $\vartheta = 40 \text{ }^\circ\text{C}$ )**

Flow

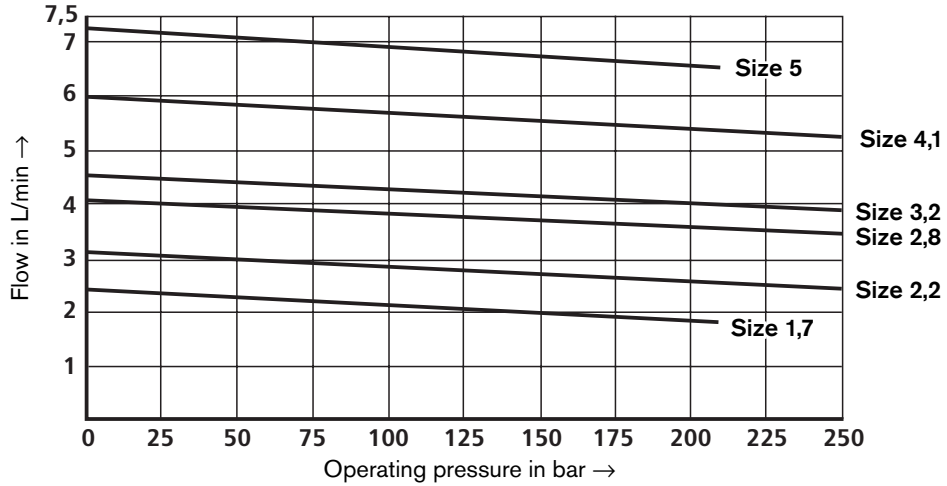

Efficiency

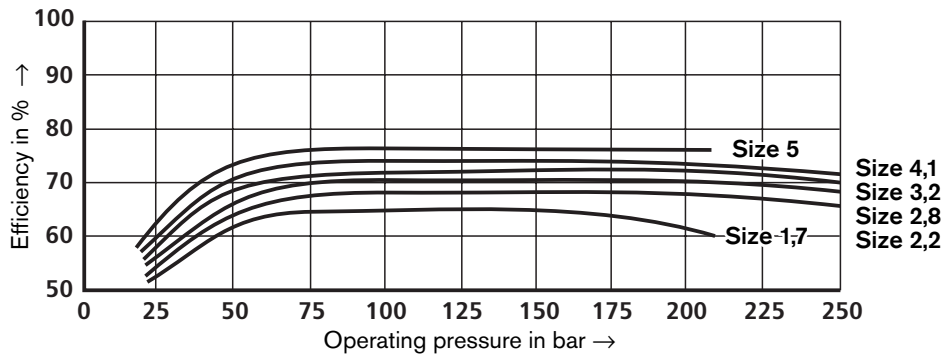

Drive power

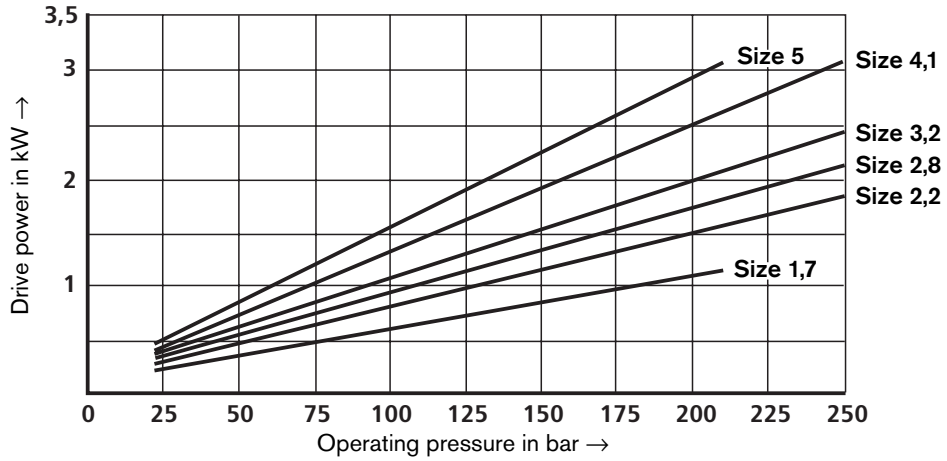

Noise pressure level

Measured in the low-reflexion anechoic chamber in line with DIN 45635, sheet 26  
Distance between microphone – pumps = 1 m

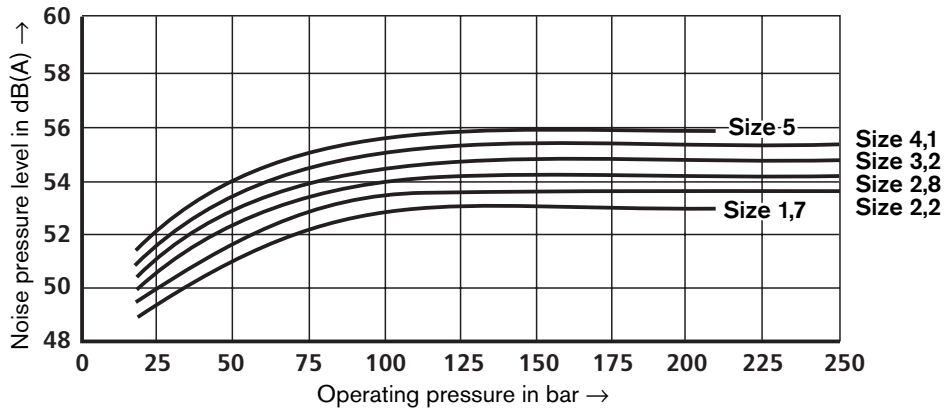

**Average characteristic curve values of frame size 2 (measured at  $n = 1450 \text{ min}^{-1}$ ;  $v = 46 \text{ mm}^2/\text{s}$  and  $\vartheta = 40 \text{ }^\circ\text{C}$ )**

**Flow**

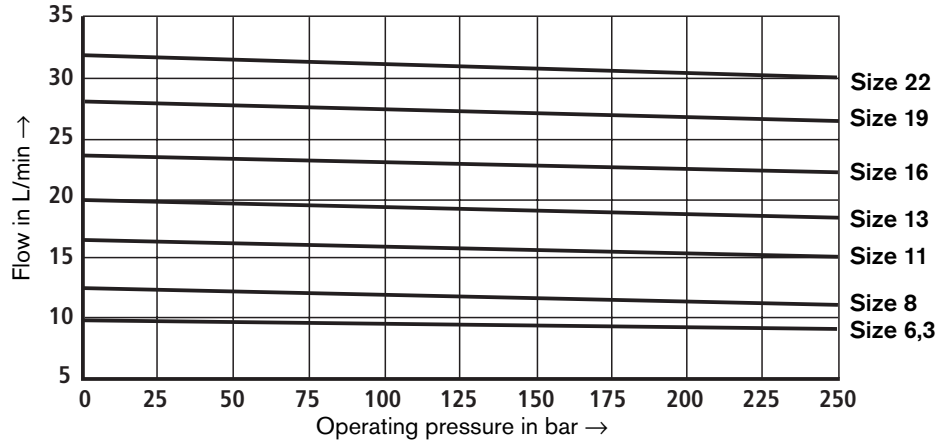

**Efficiency**

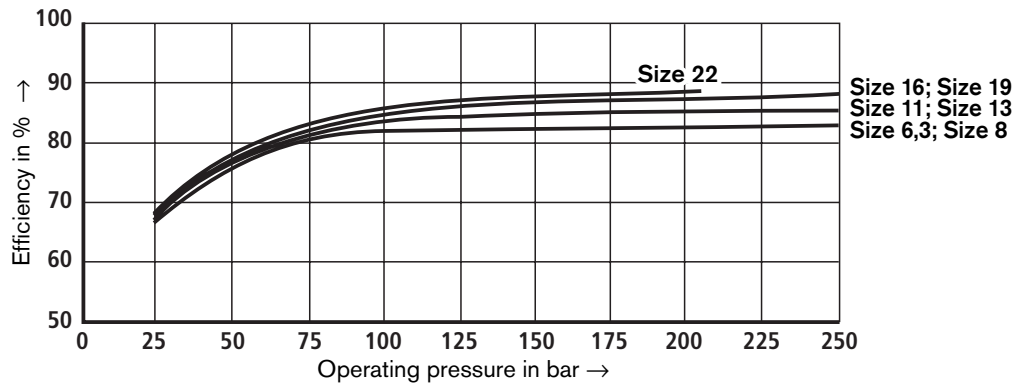

**Drive power**

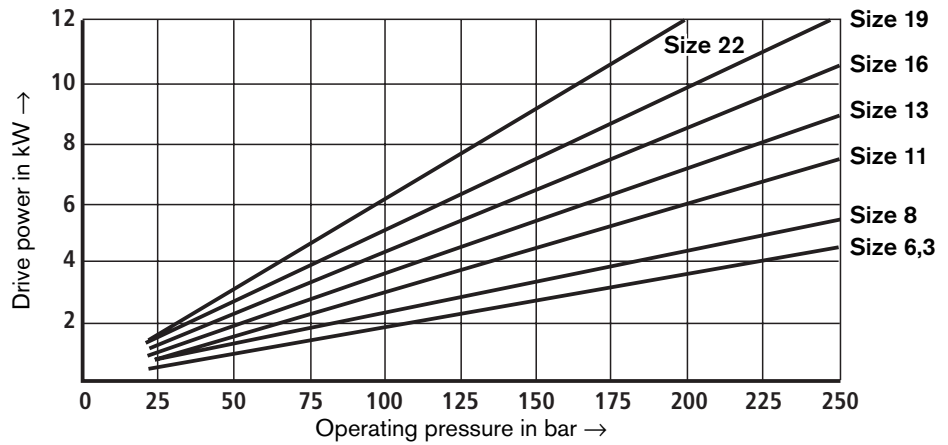

**Noise pressure level**

Measured in the low-reflexion anechoic chamber in line with DIN 45635, sheet 26

Distance between microphone – pumps = 1 m

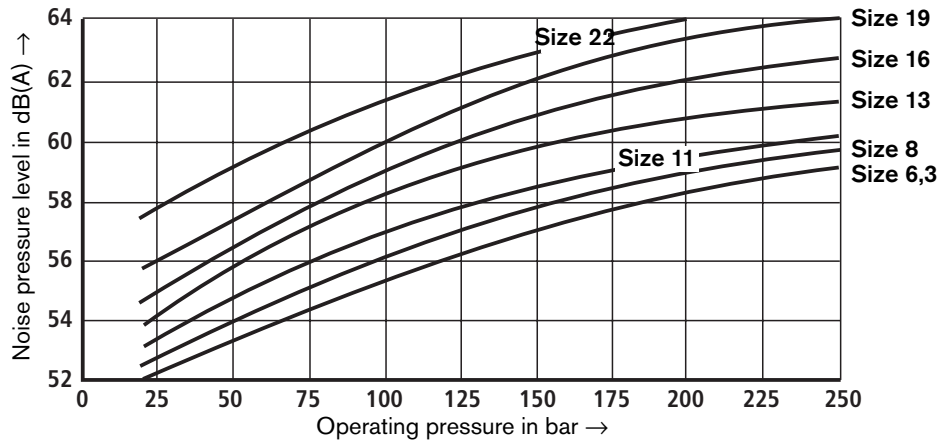

**Average characteristic curve values of frame size 3** (measured at  $n = 1450 \text{ min}^{-1}$ ;  $v = 46 \text{ mm}^2/\text{s}$  and  $\vartheta = 40 \text{ }^\circ\text{C}$ )

**Flow**

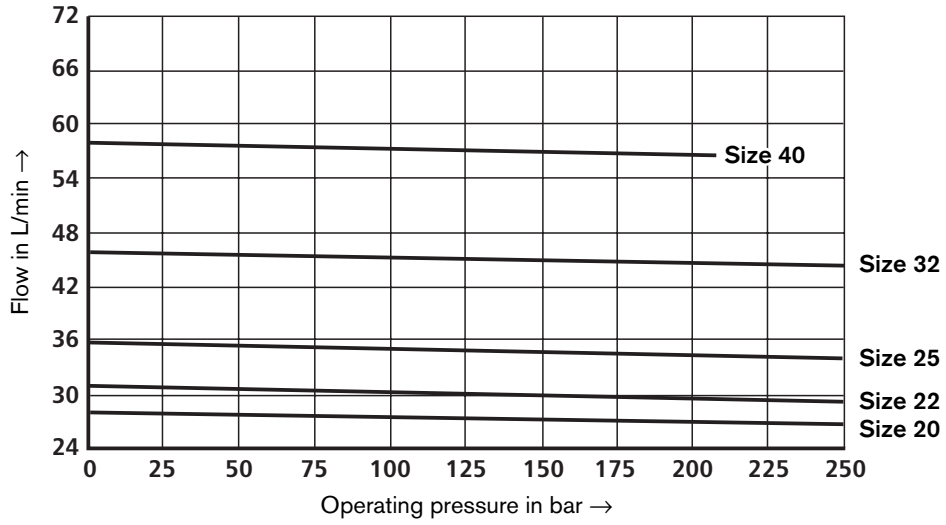

**Efficiency**

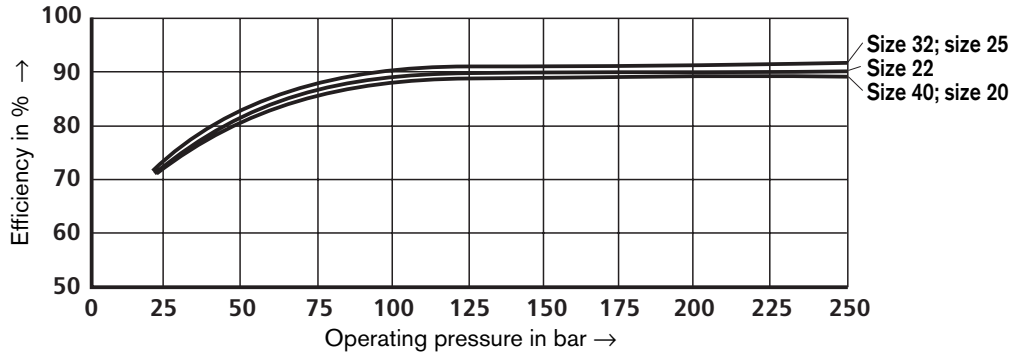

**Drive power**

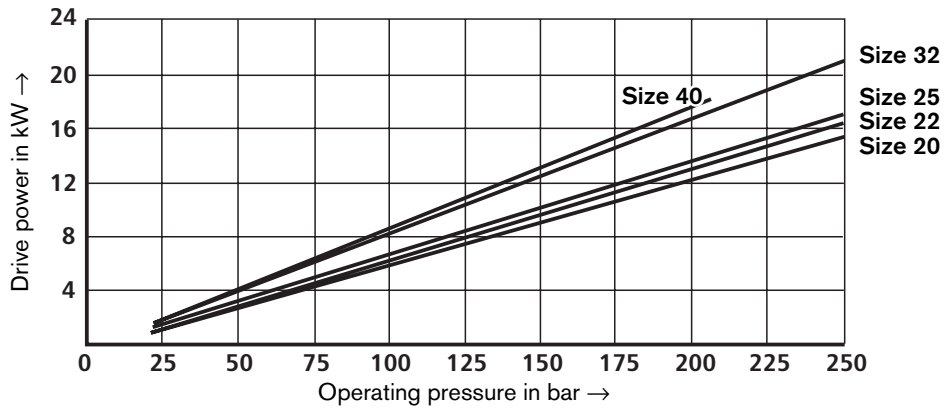

**Noise pressure level**

Measured in the low-reflexion anechoic chamber in line with DIN 45635, sheet 26

Distance between microphone - pumps = 1 m

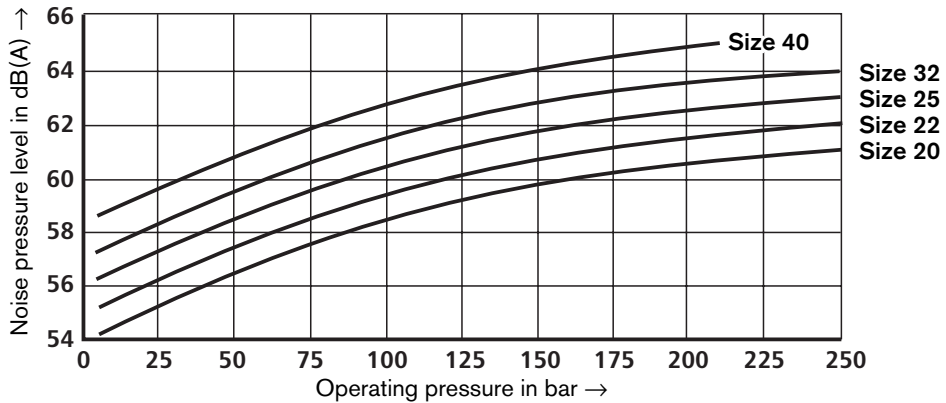

**Unit dimensions and selection tables for frame size 1 (nominal dimensions in mm)**

**PGF1-2X/...<sup>R</sup>A01VP1 (cylindrical drive shaft)**

Type	Size	Material no. "R" clockwise	Material no. "L" counter-clockwise	Dimensions				
				a	b	c	S	P
PGF1-2X/ 1,7	.A01VP1	R900932132	R900932183	29.6	49.1	62.5	G 1/4; 14	G 1/4; 12.5
PGF1-2X/ 2,2	.A01VP1	R900932133	R900050982	29.6	49.1	62.5	G 1/4; 14	G 1/4; 12.5
PGF1-2X/ 2,8	.A01VP1	R900932134	R900969246	30.7	51.4	64.8	G 3/8; 14	G 1/4; 12.5
PGF1-2X/ 3,2	.A01VP1	R900932135	R900961100	31.5	53.0	66.4	G 3/8; 14	G 1/4; 12.5
PGF1-2X/ 4,1	.A01VP1	R900932136	R900087045	33.4	56.7	70.1	G 3/8; 14	G 3/8; 12.5
PGF1-2X/ 5,0	.A01VP1	R900932137	R900969249	35.2	60.4	74.4	G 1/2; 14	G 3/8; 12.5

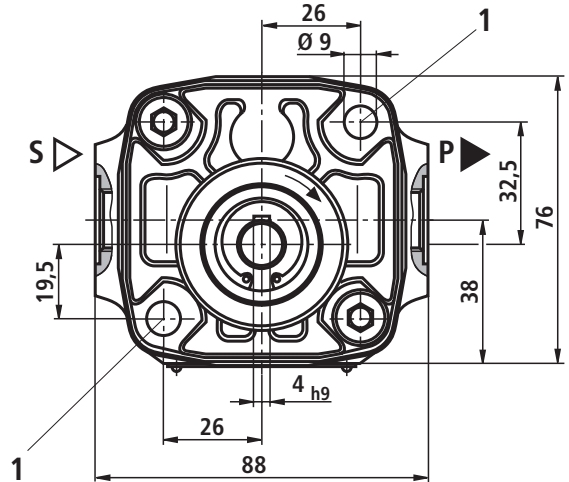
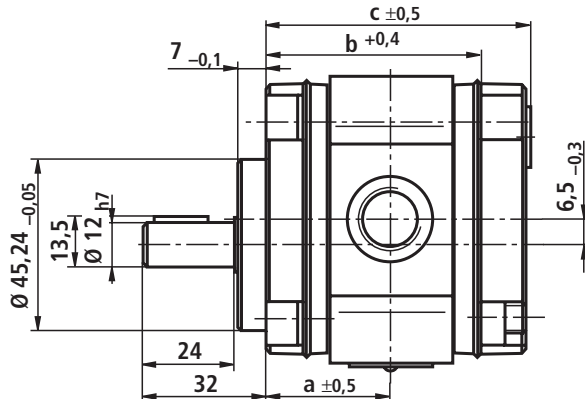

1 Through hole for socket head cap screw M8 DIN 912  
Tightening torque  $M_T = 25 (+5) \text{ Nm}$   
b = Clamping length

**PGF1-2X/...RE01VU2 (cylindrical drive shaft with output); clockwise rotation**

Type	Size	Material no.	Dimensions					
			a	b	c	d	S	P
PGF1-2X/ 1,7	RE01VU2	R900086159	48.6	49.1	85.7	79.7	G 1/4; 14	G 1/4; 12.5
PGF1-2X/ 2,2	RE01VU2	R900086160	48.6	49.1	85.7	79.7	G 1/4; 14	G 1/4; 12.5
PGF1-2X/ 2,8	RE01VU2	R900086161	49.7	51.4	88.0	82.0	G 3/8; 14	G 1/4; 12.5
PGF1-2X/ 3,2	RE01VU2	R900086162	50.5	53.0	89.6	83.6	G 3/8; 14	G 1/4; 12.5
PGF1-2X/ 4,1	RE01VU2	R900086163	52.4	56.7	93.2	87.2	G 3/8; 14	G 3/8; 12.5
PGF1-2X/ 5,0	RE01VU2	R900086164	54.2	60.4	97.0	91.0	G 1/2; 14	G 3/8; 12.5

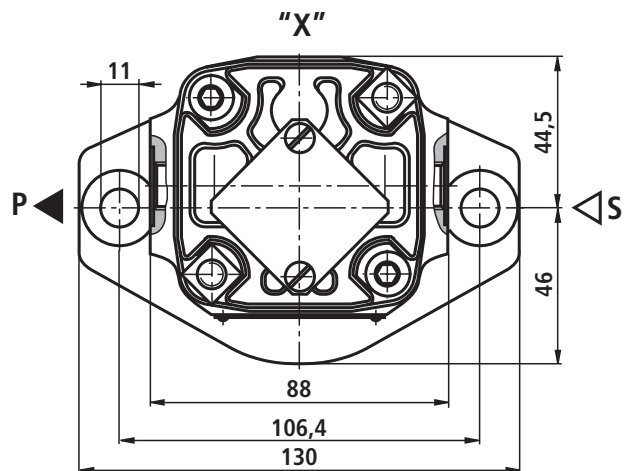
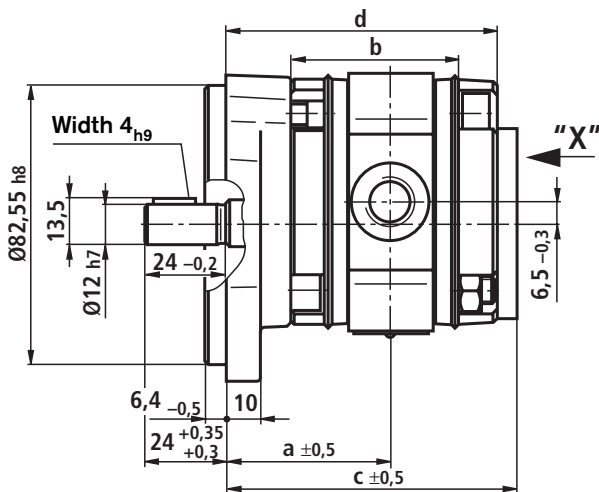

1 Through hole for socket head cap screw M8 DIN 912  
Tightening torque  $M_T = 25 (+5) \text{ Nm}$

b = Clamping length

Unit dimensions and selection tables for frame size 1 (nominal dimensions in mm)

PGF1-2X/...<sup>R</sup><sub>L</sub> N01VM (drive shaft for claw coupling); rear pump

Type	Size	Material no.		Dimensions				
		"R" clockwise	"L" counter-clockwise	a	b	d	S	P
PGF1-2X/ 1,7	.N01VM	R900969230	R900086147	29.6	49.1	62.5	G 1/4; 14	G 1/4; 12.5
PGF1-2X/ 2,2	.N01VM	R900969229	R900086148	29.6	49.1	62.5	G 1/4; 14	G 1/4; 12.5
PGF1-2X/ 2,8	.N01VM	R900201587	R900086149	30.7	51.4	64.8	G 3/8; 14	G 1/4; 12.5
PGF1-2X/ 3,2	.N01VM	R900965822	R900086150	31.5	53.0	66.4	G 3/8; 14	G 1/4; 12.5
PGF1-2X/ 4,1	.N01VM	R900088915	R900932131	33.4	56.7	70.1	G 3/8; 14	G 3/8; 12.5
PGF1-2X/ 5,0	.N01VM	R900969253	R900086152	35.2	60.4	74.4	G 1/2; 14	G 3/8; 12.5

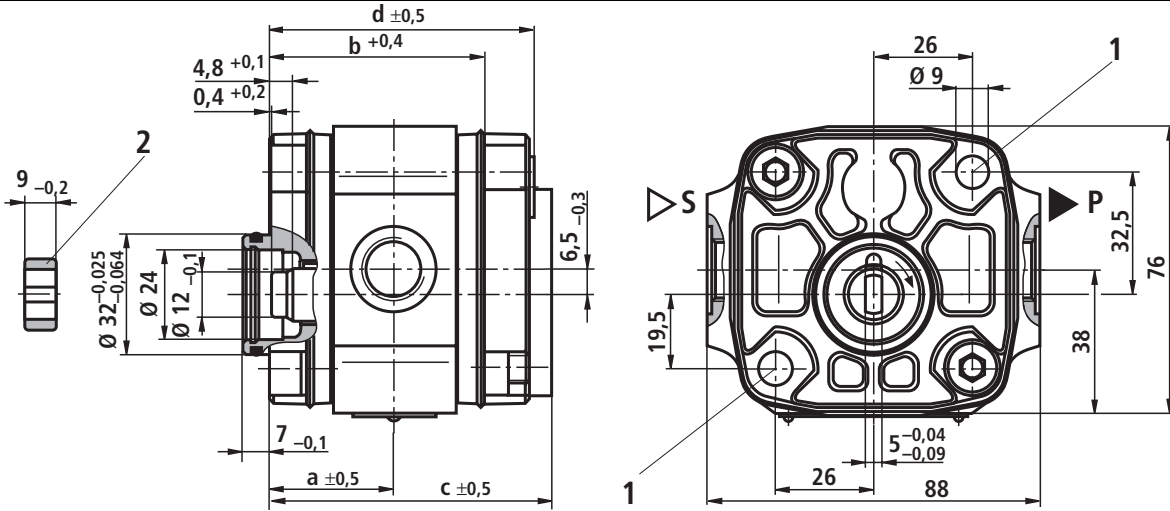

- 1 Through hole for socket head cap screw M8 DIN 912  
Tightening torque  $M_T = 25 (+5)$  Nm
- 2 Follower, material no. **R900984336** included in scope of supply  
**b** = Clamping length

PGF1-2X/...<sup>R</sup><sub>L</sub> L01VM (drive shaft for claw coupling with output); middle pump

Type	Size	Material no.		Dimensions					
		"R" clockwise	"L" counter-clockwise	a	b	c	d	S	P
PGF1-2X/ 1,7	.L01VM	R900086165	R900932093	29,6	49,1	67,1	61,1	G 1/4; 14	G 1/4; 12,5
PGF1-2X/ 2,2	.L01VM	R900086166	R900932094	29,6	49,1	67,1	61,1	G 1/4; 14	G 1/4; 12,5
PGF1-2X/ 2,8	.L01VM	R900932138	R900051293	30,7	51,4	69,4	63,4	G 3/8; 14	G 1/4; 12,5
PGF1-2X/ 3,2	.L01VM	R900086168	R900051294	31,5	53,0	71,0	65,0	G 3/8; 14	G 1/4; 12,5
PGF1-2X/ 4,1	.L01VM	R900086169	R900088913	33,4	56,7	74,7	68,7	G 3/8; 14	G 3/8; 12,5
PGF1-2X/ 5,0	.L01VM	R900086170	R900051295	35,2	60,4	78,4	72,4	G 1/2; 14	G 3/8; 12,5

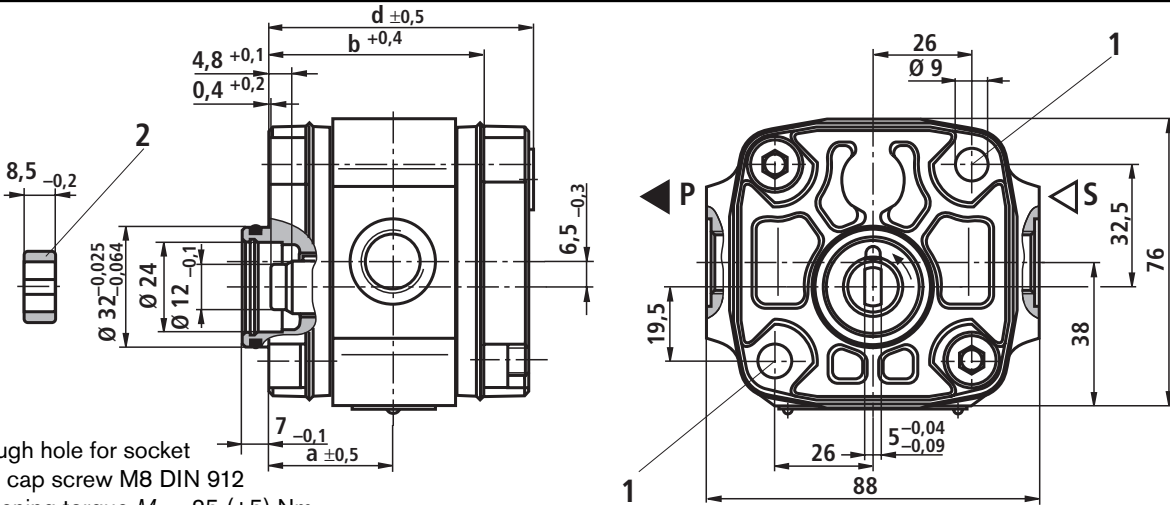

- 1 Through hole for socket head cap screw M8 DIN 912  
Tightening torque  $M_T = 25 (+5)$  Nm
- 2 Follower, material no. **R900984336** included in scope of supply  
**b** = Clamping length



**Unit dimensions and selection tables for frame size 2 (nominal dimensions in mm)**

**PGF2-2X/...RA...VP2** (cylindrical drive shaft); clockwise rotation

Type	Size	Material no.	Dimensions				
			a	b	c	S	P
PGF2-2X/	006 RA01VP2	R900932272	46	76	87	G 3/4; 16	G 1/2; 14
PGF2-2X/	008 RA01VP2	R900564037	47.8	79.5	90.5	G 3/4; 16	G 1/2; 14
PGF2-2X/	011 RA01VP2	R900568523	50.5	85	96	G 3/4; 16	G 1/2; 14
PGF2-2X/	013 RA20VP2	R900032712	53	90	101	Ø20, PC Ø40 <sup>1)</sup>	Ø12, PC Ø35 <sup>1)</sup>
PGF2-2X/	016 RA20VP2	R900932275	55.5	95	106	Ø26, PC Ø55 <sup>1)</sup>	Ø12, PC Ø35 <sup>1)</sup>
PGF2-2X/	019 RA20VP2	R900571401	58.5	101	112	Ø26, PC Ø55 <sup>1)</sup>	Ø12, PC Ø35 <sup>1)</sup>

<sup>1)</sup> PC = pitch circle

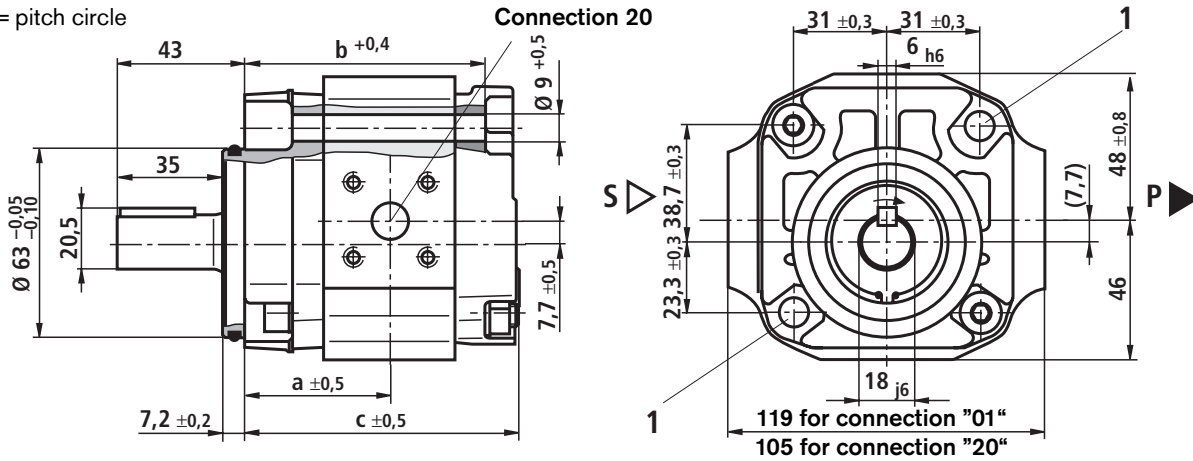

1 Through hole for socket head cap screw M8 DIN 912  
Tightening torque  $M_A = 25 (+5)$  Nm

b = Clamping length

**PGF2-2X/...RE...VE4** (cylindrical drive shaft with output); clockwise rotation

Type	Size	Material no.	Dimensions				
			a	c	d	S	P
PGF2-2X/	006 RE01VE4	R900932265	63	114	104	G 3/4; 16	G 1/2; 14
PGF2-2X/	008 RE01VE4	R900932266	64.8	117.5	107.5	G 3/4; 16	G 1/2; 14
PGF2-2X/	011 RE01VE4	R900932271	67.5	123	113	G 3/4; 16	G 1/2; 14
PGF2-2X/	013 RE20VE4	R900943181	70	128	118	Ø20, PC Ø40 <sup>1)</sup>	Ø12, PC Ø35 <sup>1)</sup>
PGF2-2X/	016 RE20VE4	R900932193	72.5	133	123	Ø20, PC Ø40 <sup>1)</sup>	Ø12, PC Ø35 <sup>1)</sup>
PGF2-2X/	019 RE20VE4	R900943182	75.5	139	129	Ø26, PC Ø55 <sup>1)</sup>	Ø12, PC Ø35 <sup>1)</sup>
PGF2-2X/	022 RE20VE4	R900932126	78.5	144	134	Ø26, PC Ø55 <sup>1)</sup>	Ø12, PC Ø35 <sup>1)</sup>

<sup>1)</sup> PC = pitch circle

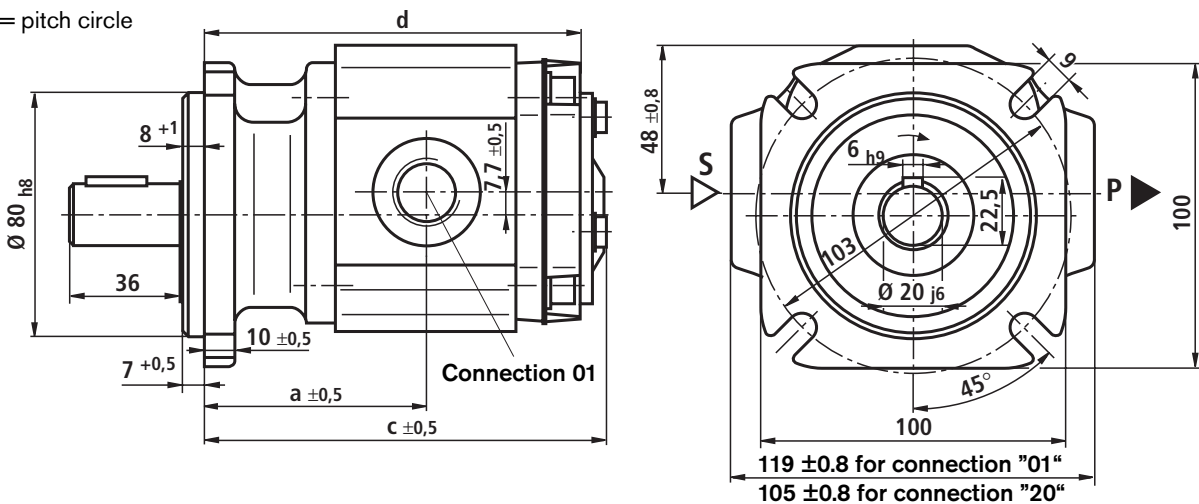

Courtesy of CMA/Flodyne/Hydradyne • Motion Control • Hydraulic • Pneumatic • Electrical • Mechanical • (800) 426-5480 • www.cmafh.com

Unit dimensions and selection tables for frame size 2 (nominal dimensions in mm)

PGF2-2X/...  $\begin{matrix} R \\ L \end{matrix}$  J.VU2 (splined drive shaft with output)

Type	Size	Material no.		Dimensions				
		"R" clockwise	"L" counter-clockwise	a	c	d	S	P
PGF2-2X/	006 RJ01VU2	R900931660	R900247697	65	116	106	G 3/4; 16	G 1/2; 14
PGF2-2X/	008 RJ01VU2	R900953363	R900247698	67	119.5	109.5	G 3/4; 16	G 1/2; 14
PGF2-2X/	011 RJ01VU2	R900938281	R900247699	69.5	125	115	G 3/4; 16	G 1/2; 14
PGF2-2X/	013 RJ20VU2	R900932264	R900969259	72	130	120	Ø20, PC Ø40 <sup>1)</sup>	Ø12, PC Ø35 <sup>1)</sup>
PGF2-2X/	016 RJ20VU2	R900932085	R900936173	74.5	135	125	Ø20, PC Ø40 <sup>1)</sup>	Ø12, PC Ø35 <sup>1)</sup>
PGF2-2X/	019 RJ20VU2	R900022882	R900984300	77.5	141	131	Ø26, PC Ø55 <sup>1)</sup>	Ø12, PC Ø35 <sup>1)</sup>
PGF2-2X/	022 RJ20VU2	R900054053	R900935718	80.5	147	137	Ø26, PC Ø55 <sup>1)</sup>	Ø12, PC Ø35 <sup>1)</sup>

<sup>1)</sup> PC = pitch circle

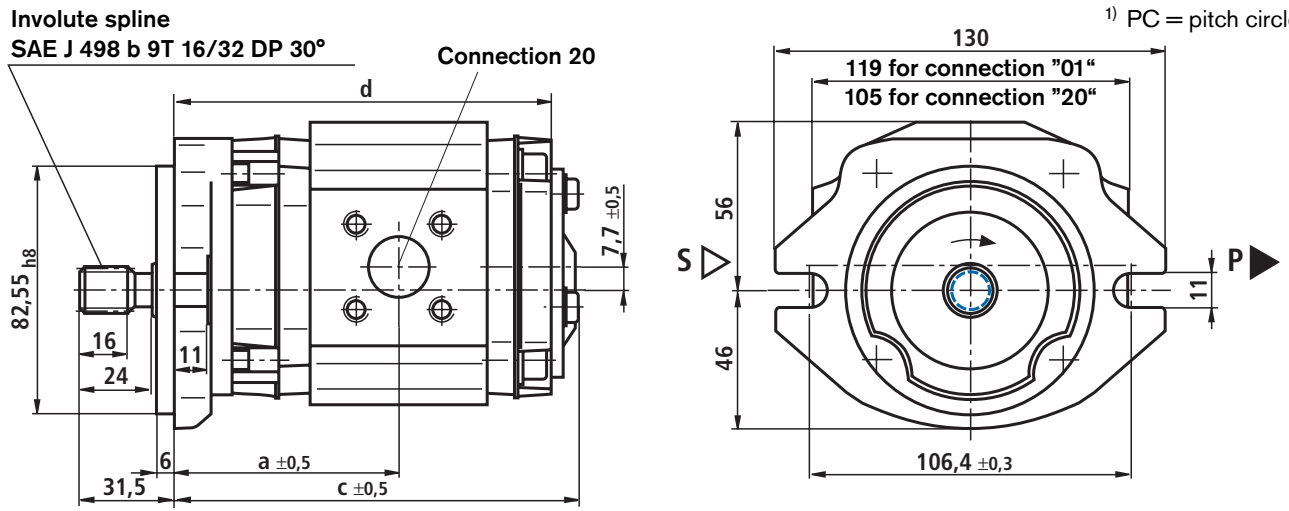

PGF2-2X/...RT20VU2 (splined drive shaft)

Type	Size	Material no.		Dimensions			
		"R" clockwise	"L" counter-clockwise	a	c	S	P
PGF2-2X/	006 RT20VU2	-	-	65.0	106.2	Ø20; PC Ø40 <sup>1)</sup>	Ø12; PC Ø35 <sup>1)</sup>
PGF2-2X/	008 RT20VU2	R900983482	-	67.0	109.7	Ø20; PC Ø40 <sup>1)</sup>	Ø12; PC Ø35 <sup>1)</sup>
PGF2-2X/	011 RT20VU2	-	-	69.5	115.2	Ø20; PC Ø40 <sup>1)</sup>	Ø12; PC Ø35 <sup>1)</sup>
PGF2-2X/	013 RT20VU2	R900573243	-	72.0	120.2	Ø20; PC Ø40 <sup>1)</sup>	Ø12; PC Ø35 <sup>1)</sup>
PGF2-2X/	016 RT20VU2	R900929805	-	74.5	125.2	Ø20; PC Ø40 <sup>1)</sup>	Ø12; PC Ø35 <sup>1)</sup>
PGF2-2X/	019 RT20VU2	R900983485	-	77.5	131.0	Ø26; PC Ø55 <sup>1)</sup>	Ø12; PC Ø35 <sup>1)</sup>

<sup>1)</sup> PC = pitch circle

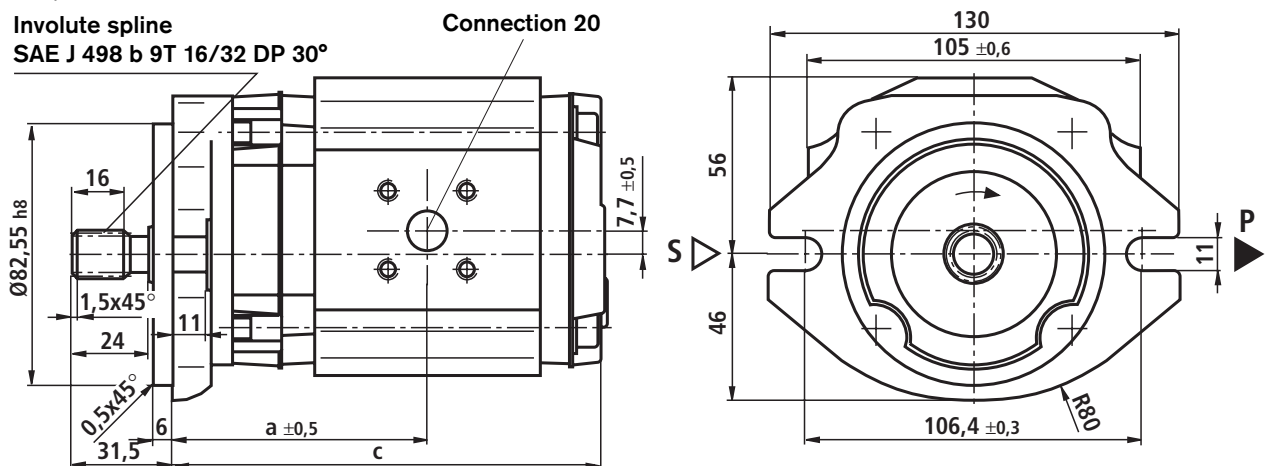

**Unit dimensions and selection tables for frame sizes 2 and 3 (nominal dimensions in mm)**

**PGF2-2X/...RS20VU2 (conical drive shaft)**

Type	Size	Material no. "R" clockwise	Dimensions			
			a	c	S	P
PGF2-2X/	006 RS20VU2	R900946180	49.2	90.4	Ø20; PC Ø40 <sup>1)</sup>	Ø12; PC Ø35 <sup>1)</sup>
PGF2-2X/	008 RS20VU2	R900619661	50.7	93.9	Ø20; PC Ø40 <sup>1)</sup>	Ø12; PC Ø35 <sup>1)</sup>
PGF2-2X/	011 RS20VU2	R900946237	53.7	99.4	Ø20; PC Ø40 <sup>1)</sup>	Ø12; PC Ø35 <sup>1)</sup>
PGF2-2X/	013 RS20VU2	R900619662	56.2	104.4	Ø20; PC Ø40 <sup>1)</sup>	Ø12; PC Ø35 <sup>1)</sup>
PGF2-2X/	016 RS20VU2	R900619663	58.7	109.4	Ø20; PC Ø40 <sup>1)</sup>	Ø12; PC Ø35 <sup>1)</sup>
PGF2-2X/	019 RS20VU2	R900955134	61.7	115.4	Ø26; PC Ø55 <sup>1)</sup>	Ø12; PC Ø35 <sup>1)</sup>
PGF2-2X/	022 RS20VU2	R900950915	64.7	121.4	Ø26; PC Ø55 <sup>1)</sup>	Ø12; PC Ø35 <sup>1)</sup>

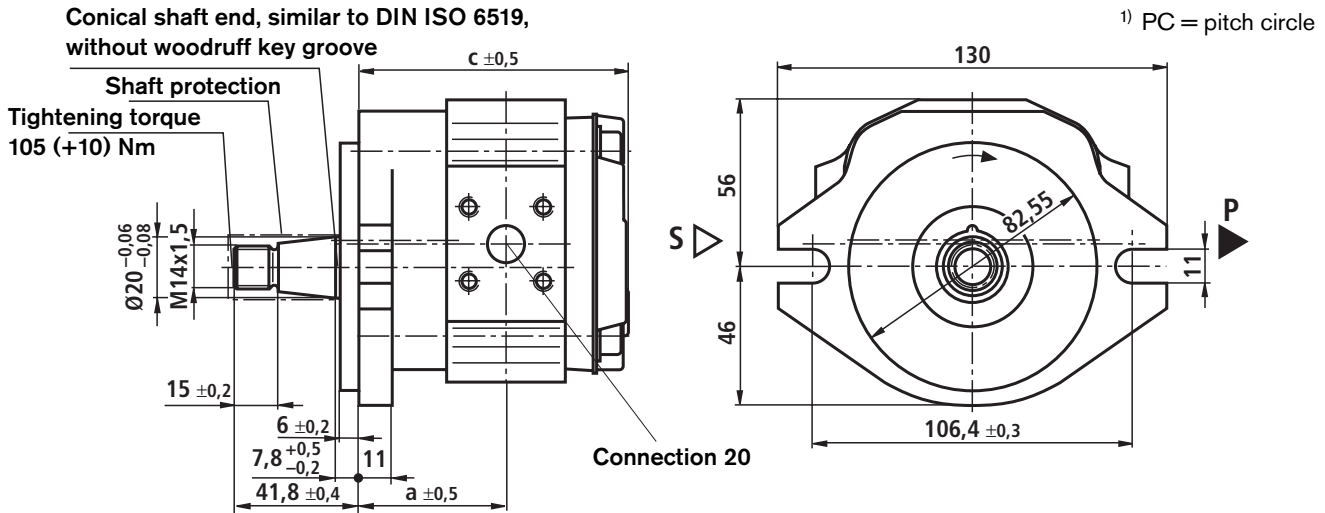

**PGF3-3X/... N...VM (drive shaft for claw coupling); counter-clockwise rotation; rear pump**

Type	Size	Material no. "R" clockwise	Material no. "L" counter-clockwise	Dimensions				
				a	b	d	S	P
PGF3-3X/	020 .N20VM	R900969263	R900051928	60.5	101.5	112.5	Ø26, PC Ø55 <sup>1)</sup>	Ø12, PC Ø35 <sup>1)</sup>
PGF3-3X/	022 .N20VM	R900969264	R900202496	61.5	103.5	114.5	Ø26, PC Ø55 <sup>1)</sup>	Ø12, PC Ø35 <sup>1)</sup>
PGF3-3X/	025 .N20VM	R900983758	R900034369	63.5	107.5	118.5	Ø26, PC Ø55 <sup>1)</sup>	Ø12, PC Ø35 <sup>1)</sup>
PGF3-3X/	032 .N07VM	R900937747	R900051539	68	116.5	127.5	SAE 1 1/4"	SAE 3/4"
PGF3-3X/	040 .N07VM	R900965546	R900932122	73	126.5	137.5	SAE 1 1/4"	SAE 3/4"

1) PC = pitch circle

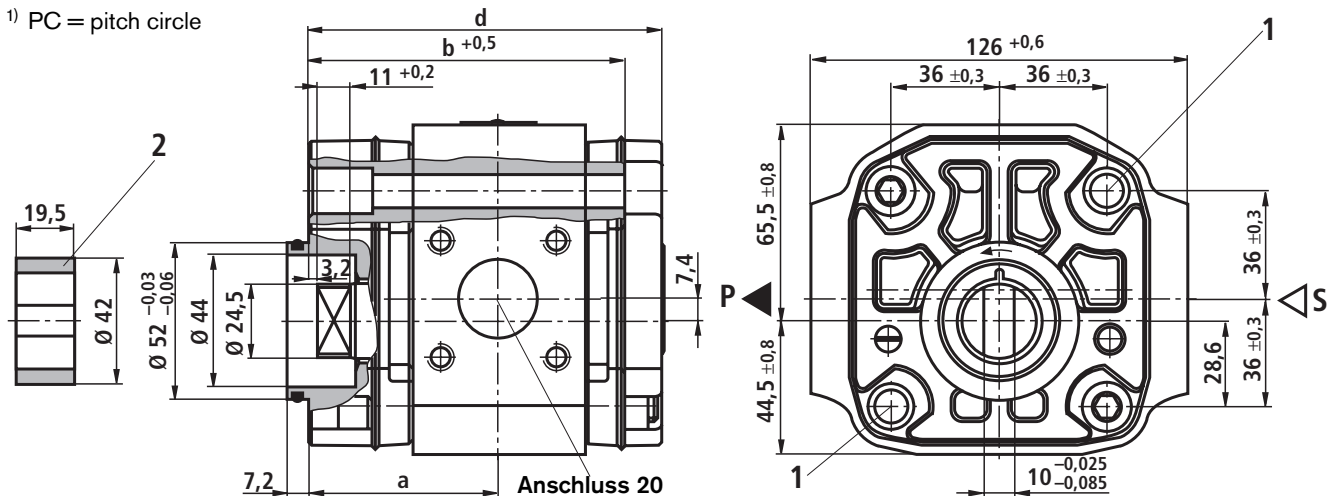

**Unit dimensions and selection tables for frame size 3 (nominal dimensions in mm)**

**PGF3-3X/... R J07VU2 (splined drive shaft with output)**

Type	Size	Material no. "R" clockwise	Material no. "L" counter-clockwise	Dimensions				
				a	c	d	S	P
PGF3-3X/ 020	J07VU2	R900983792	R900948466	79.5	144.5	134.5	SAE 1 1/4"	SAE 3/4"
PGF3-3X/ 022	J07VU2	R900931657	R900969265	80.5	146.5	136.5	SAE 1 1/4"	SAE 3/4"
PGF3-3X/ 025	J07VU2	R900029617	R900950057	82.5	150.5	140.5	SAE 1 1/4"	SAE 3/4"
PGF3-3X/ 032	J07VU2	R900029561	R900984213	87	159.5	149.5	SAE 1 1/4"	SAE 3/4"
PGF3-3X/ 040	J07VU2	R900931426	R900969266	95	169.5	159.5	SAE 1 1/4"	SAE 3/4"

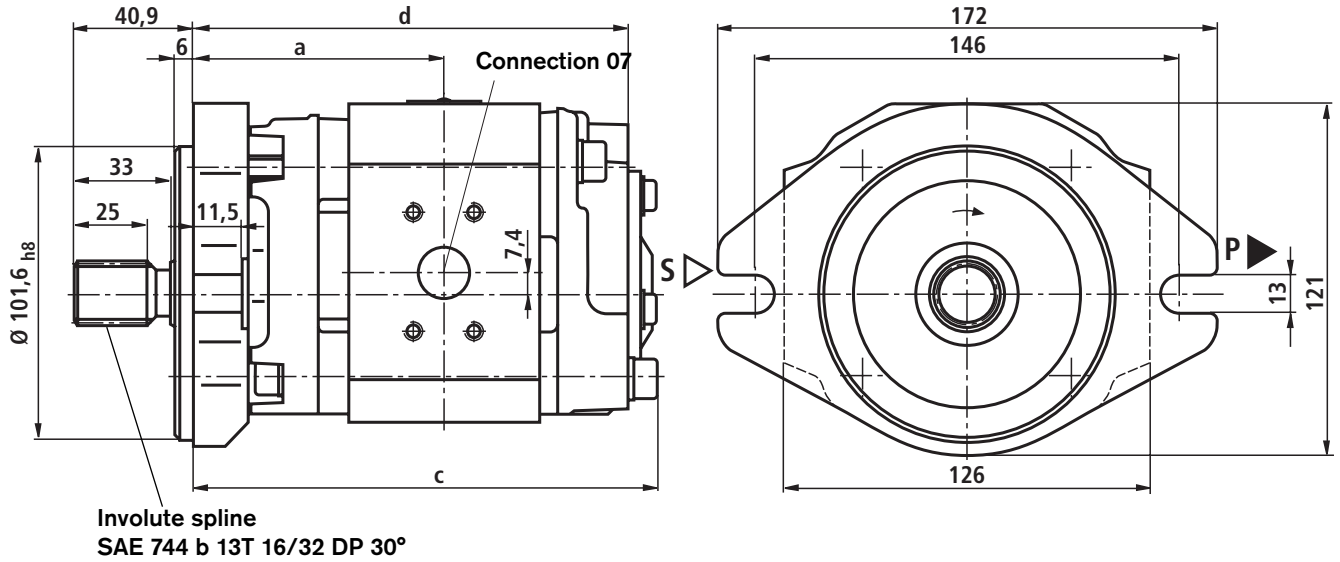

**PGF3-3X/...RE07VE4 (cylindrical drive shaft with output); clockwise rotation**

Type	Size	Material no.	Dimensions				
			a	c	d	S	P
PGF3-3X/ 020	RE07VE4	R900063299	71	136	126	SAE 1 1/4"	SAE 3/4"
PGF3-3X/ 022	RE07VE4	R900035217	72	138	128	SAE 1 1/4"	SAE 3/4"
PGF3-3X/ 025	RE07VE4	R900932088	74	142	132	SAE 1 1/4"	SAE 3/4"
PGF3-3X/ 032	RE07VE4	R900932112	78.5	151	141	SAE 1 1/4"	SAE 3/4"
PGF3-3X/ 040	RE07VE4	R900932111	83.5	161	151	SAE 1 1/4"	SAE 3/4"

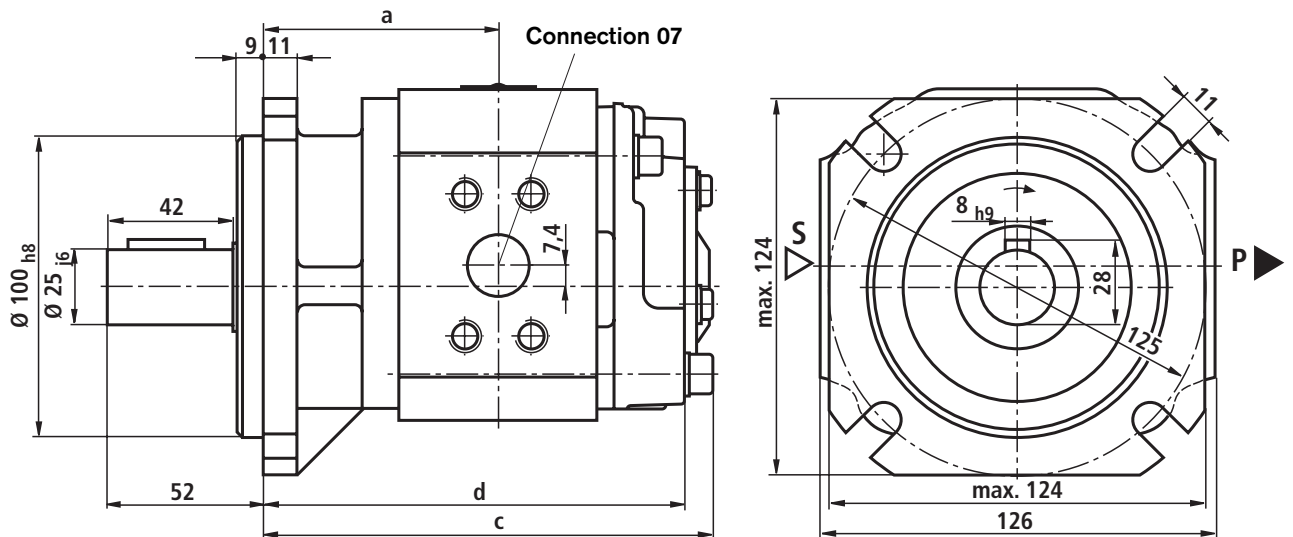

**Unit dimensions and selection tables for frame size 3 (nominal dimensions in mm)**

**PGF3-3X/...<sup>R</sup>L07VM** (drive shaft for claw coupling with output); middle pump

Type	Size	Material no.		Dimensions						
		"R" clockwise	"L" counter-clockwise	a	b	c	d	S	P	
PGF3-3X/	020	L07VM	R900073539	R900758721	60.5	101.5	125.5	115.5	SAE 1 1/4"	SAE 3/4"
PGF3-3X/	022	L07VM	R900073077	R900743099	61.5	103.5	127.5	117.5	SAE 1 1/4"	SAE 3/4"
PGF3-3X/	025	L07VM	R900960119	R900932121	63.5	107.5	131.5	121.5	SAE 1 1/4"	SAE 3/4"
PGF3-3X/	032	L07VM	R900034370	R900074369	68	116.5	140.5	130.5	SAE 1 1/4"	SAE 3/4"
PGF3-3X/	040	L07VM	R900058224	R900083281	73	126.5	150.5	140.5	SAE 1 1/4"	SAE 3/4"

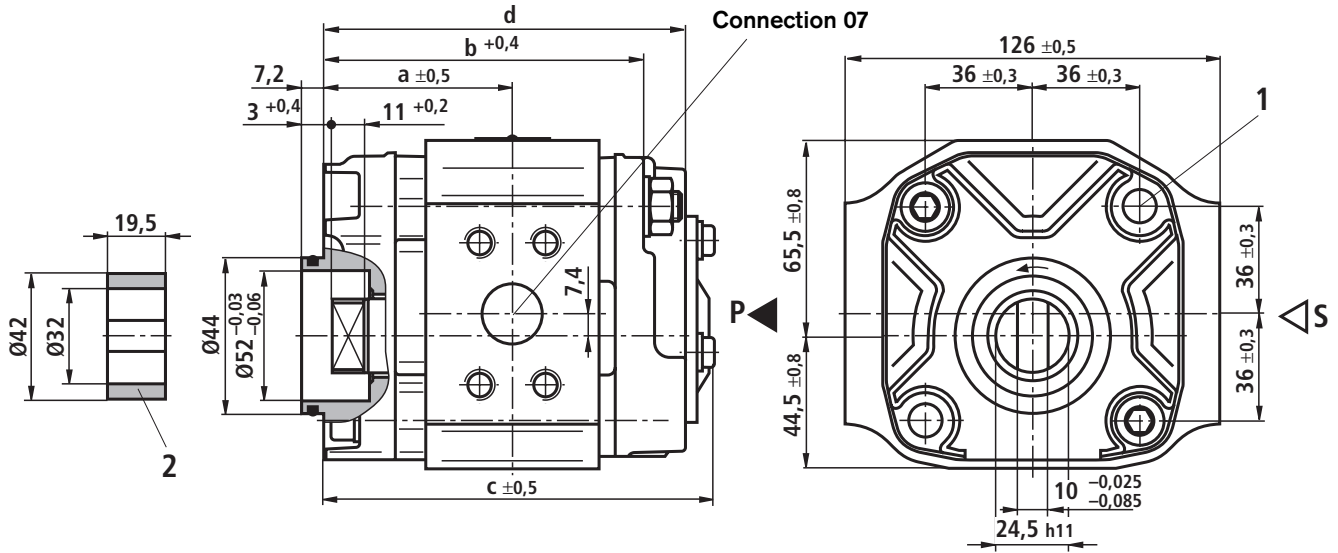

1 Through hole for socket head cap screw M10 DIN 912  
Tightening torque  $M_T = 49 (+5)$  Nm

2 Follower, mat. no. **R900983603** included in scope of supply  
b = Clamping length

**PGF3-3X/...RS07VM** (conical drive shaft)

Type	Size	Material no.		Dimensions				
		"R" clockwise		a	b	c	S	P
PGF3-3X/	020	RS07VM	R900965136	60.5	101.5	112.5	SAE 1 1/4"	SAE 3/4"
PGF3-3X/	022	RS07VM	R900969222	61.5	103.5	114.5	SAE 1 1/4"	SAE 3/4"
PGF3-3X/	025	RS07VM	R900969223	63.5	107.5	118.5	SAE 1 1/4"	SAE 3/4"
PGF3-3X/	032	RS07VM	R900984249	68	116.5	127.5	SAE 1 1/4"	SAE 3/4"
PGF3-3X/	040	RS07VM	R900969224	76	126.5	137.5	SAE 1 1/4"	SAE 3/4"

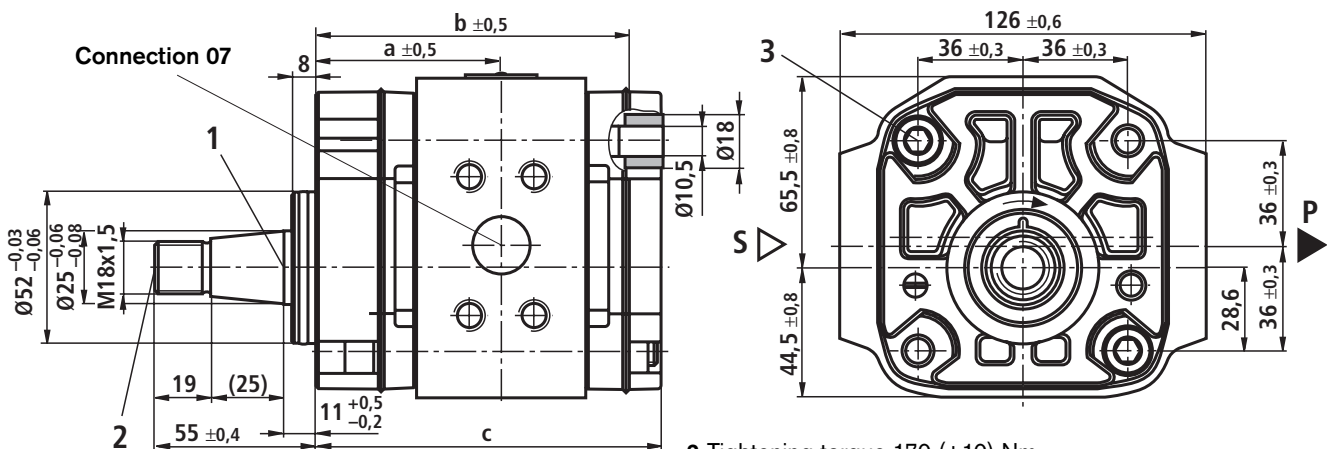

1 Shaft end conical, similar to DIN ISO 6519,  
without woodruff key groove

2 Tightening torque 170 (+10) Nm  
3 Fixing screw M10, tightening torque 49 (+5) Nm  
b = Clamping length

**Unit dimensions and selection tables for frame size 3 (nominal dimensions in mm)**

PGF3-3X/...  $\begin{matrix} R \\ L \end{matrix}$  O07VK4 (conical drive shaft with output)

Type	Size	Material no. "R" clockwise	Material no. "L" counter-clockwise	Dimensions					
				a	b	c	S	P	
PGF3-3X/	020	.O07VK4	R900969302	R900619706	71	126	136.5	SAE 1 1/4"	SAE 3/4"
PGF3-3X/	022	.O07VK4	R900619709	R900619708	72	128	138.5	SAE 1 1/4"	SAE 3/4"
PGF3-3X/	025	.O07VK4	R900943169	R900619710	74	132	142.5	SAE 1 1/4"	SAE 3/4"
PGF3-3X/	032	.O07VK4	R900943168	R900943167	78.5	141	151.5	SAE 1 1/4"	SAE 3/4"
PGF3-3X/	040	.O07VK4	R900619712	R900619711	83.5	151	161.5	SAE 1 1/4"	SAE 3/4"

**Splined shaft profile B8x32x35**  
similar to DIN ISO 14 (slip-on sleeve)

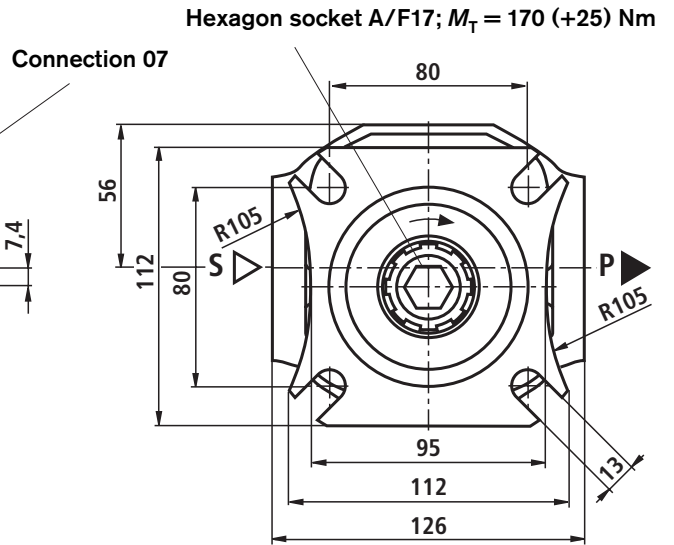
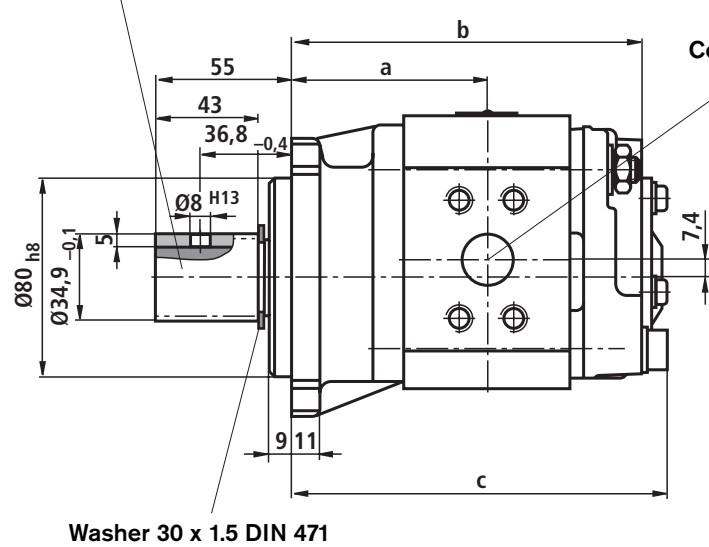

### Suction and pressure ports (nominal dimensions in mm)

**PGF1, type of connection 01**  
BSP thread to ISO 228/1

Size	Suction port dimensions		Pressure port dimensions	
	s	f	p	g
1,7	G 1/4; 14	23	G 1/4; 12.5	23
2,2	G 1/4; 14	23	G 1/4; 12.5	23
2,8	G 3/8; 14	26	G 1/4; 12.5	23
3,2	G 3/8; 14	26	G 1/4; 12.5	23
4,1	G 3/8; 14	26	G 3/8; 12.5	26
5,0	G 1/2; 14	27	G 3/8; 12.5	26

**PGF2, type of connection 01**  
BSP thread to ISO 228/1

Size	Suction port dimensions		Pressure port dimensions	
	s	f	p	g
006	G 3/4; 16	35	G 1/2; 14	35
008	G 3/4; 16	35	G 1/2; 14	35
011	G 3/4; 16	35	G 1/2; 14	35
013	G 3/4; 16	35	G 1/2; 14	35
016	G 1; 18	40	G 1/2; 14	35
019	G 1; 18	40	G 1/2; 14	35
022	G 1; 18	40	G 1/2; 14	35

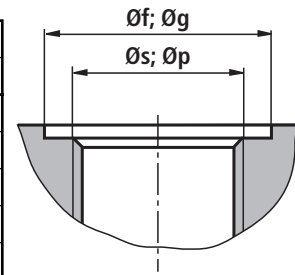

**PGF2, type of connection 20 square flange connection**

Size	Suction port dimensions						Pressure port dimensions					
	d	b	PC	Thread	t	M in Nm	d	b	PC	Thread	t	M in Nm
006	20	28.3	40	M6	10	10	12	24.8	35	M6	12	10
008	20	28.3	40	M6	10	10	12	24.8	35	M6	12	10
011	20	28.3	40	M6	10	10	12	24.8	35	M6	12	10
013	20	28.3	40	M6	10	10	12	24.8	35	M6	12	10
016	20	28.3	40	M6	10	10	12	24.8	35	M6	12	10
019	26	38.9	55	M8	12	25	12	24.8	35	M6	12	10
022	26	38.9	55	M8	12	25	12	24.8	35	M6	12	10

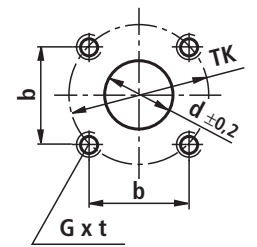

Tightening torque: *M*

**PGF3, type of connection 20 square flange connection**

Size	Suction port dimensions						Pressure port dimensions					
	d	b	PC	Thread	t	M in Nm	d	b	PC	Thread	t	M in Nm
020	26	38.9	55	M8	12	25	12	24.8	35	M6	10	10
022	26	38.9	55	M8	12	25	12	24.8	35	M6	10	10
025	26	38.9	55	M8	12	25	12	24.8	35	M6	10	10
032	26	38.9	55	M8	12	25	20	38.9	55	M8	12	25
040	26	38.9	55	M8	12	25	20	38.9	55	M8	12	25

**PGF3, Type of connection 07 SAE flange connection**

Suction port SAE 1 1/4" S

Pressure port SAE 3/4" S

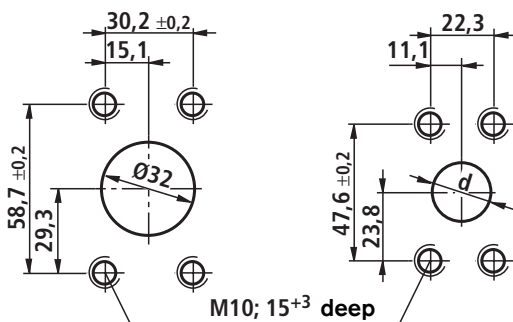

Tightening torque: 49 (+5) Nm

Size	d
020	16
022	16
025	16
032	20
040	20

## Suction and pressure flanges

### Connection 20

Pressure flange types **PGF2** and **PGF3**  
of sizes 020, 022 and 025 with pitch circle Ø 35 mm

Flange type	Designation	Material no.
Flange QA	35,0-4x6,4→L10-PN315	R900321436
Flange QA	35,0-4x6,4→L12-PN315	R900321437
Flange QA	35,0-4x6,4→S16-PN315	R900323235
Angled flange QA	35,0-4x6,4→L10-PN315	R900321444
Angled flange QA	35,0-4x6,4→L12-PN315	R900321445
Angled flange QA	35,0-4x6,4→L18-PN250	R900991790
Angled flange QA	35,0-4x6,4→S16-PN315	R900321447
Angled flange QA	35,0-4x6,4→S20-PN315	R900321448

Suction flange types **PGF2** and **PGF3**  
of sizes 006 to 016 with pitch circle Ø 40 mm

Flange type	Designation	Material no.
Flange QA	40,0-4x6,4→L18-PN100	R900321434
Flange QA	40,0-4x6,4→L22-PN100	R900321435
Flange QA	40,0-4x6,4→L28-PN100	R900323237
Angled flange QA	40,0-4x6,4→L18-PN100	R900321441
Angled flange QA	40,0-4x6,4→L22-PN100	R900321442
Angled flange QA	40,0-4x6,4→L28-PN100	R900321443

Suction and pressure flange type **PGF3** of sizes 020 to 040 and  
**PFG2** of sizes 019 and 022 with pitch circle Ø 55 mm,  $p_{max}$  100 bar

Flange type	Designation	Material no.
Flange QA	55,0-4x8,4→L42-PN100	R900702278
Angled flange QA	55,0-4x8,4→L42-PN100	R900071314

For dimensions and detailed information, see AB 22-35 and  
RN 206.21.

### Connection 07

Suction flange type **PGF3**

Designation	Material no.
SAE 1 1/4S-G 1 1/4 (with threaded connection)	R900014153
SAE 1 1/4S-42,0x3,0 (with welded neck)	R900012341

Pressure flange type **PGF3**

Designation	Material no.
SAE 3/4S-G 3/4 (with threaded connection)	R900024202
SAE 3/4S-25,0x4,0 (with welded neck)	R900056163
SAE 3/4S-20,0x3,0 (with welded neck)	R900056167

For dimensions and detailed information, see AB 22-15.

## Multiple pumps – ordering code

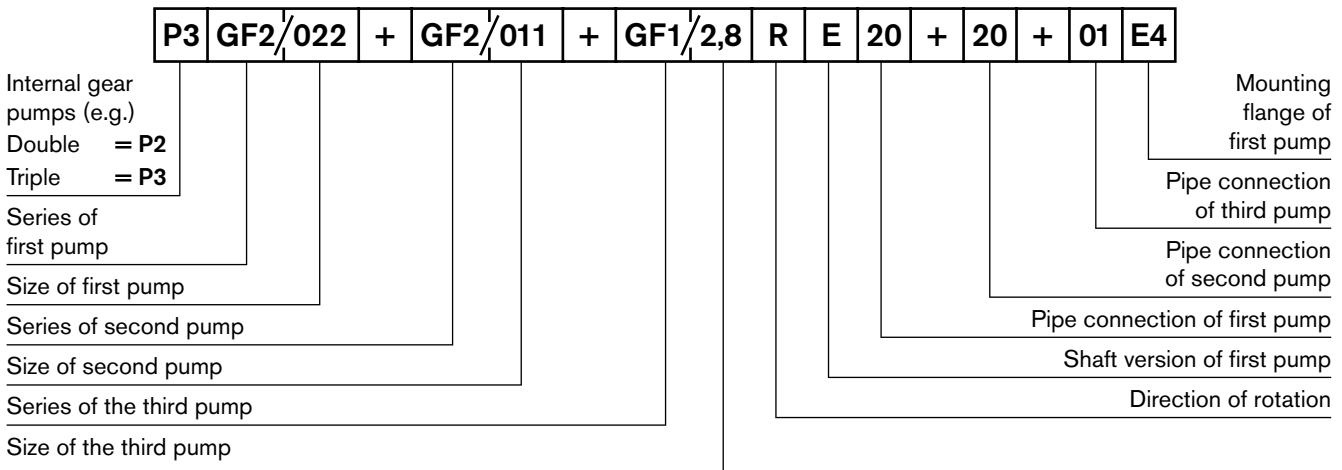

## Multiple pumps – engineering notes

- The valid general technical data are the same as for single pumps (see pages 4 and 5).
- Combined pumps must all have the same direction of rotation.
- The pump that is subjected to the greatest loads should be the first pump.
- The engineer must verify the maximum through-drive torque for every application. This is also valid for existing (coded) multiple pumps.

Maximum **drive torques** in Nm

Shaft	N	L	A	E	J
<b>PGF1</b>	14	14	30	30	–
<b>PGF2</b>	70	70	70	140	140
<b>PGF3</b>	140	140	–	230	230

- Common suction is **not** possible.
- For reasons of strength and stability, we recommend the use of ISO 4-hole mounting flanges to VDMA "E4" for combinations of three or more pumps.

### Selection:

- The front pump must have shaft version E, J or L.
- The middle pmp must have shaft version L.
- The rear pump must have shaft version N.
- If a pump of the next smaller frame size is to be mounted, the first pump must show "K" at the end of the designation (e.g. PGF3 + PGF2 ⇒ front pump: PGF3-3X/032RJ07VU2K)

- The drive torque of a pump stage can be calculated as follows:

$$T = \frac{\Delta p \cdot V \cdot 0.0159}{\eta_{\text{hydr.-mech.}}}$$

- $T$ : drive torque in Nm
- $\Delta p$ : operating pressure in bar
- $V$ : displacement in cm<sup>3</sup>
- $\eta$ : hydraulic-mechanical efficiency

Maximum **output torques** in Nm

Shaft	N	L	A	E	J
<b>PGF1</b>	–	14	–	14	–
<b>PGF2</b>	–	70	–	70	70
<b>PGF3</b>	–	140	–	140	140

- Before operating pump combinations with different media, please consult Rexroth Hydraulics.
- PGF combinations are assembled without combination parts
- The pumps are not sealed from each other.

### Dimensions:

- The dimensions of connections are the same as for single pumps (see page 18).
- The total length of the pump is obtained by adding up the dimensions "d" of the single pumps (see pages 9 to 17).
- With the combination of PGF2 and PGF1 the constructive length of PGF2 (dimension d) increases by 4.5 mm.  
With the combination of PGF3 and PGF2 the constructive length of PGF3 (dimension d) increases by 2 mm.  
With the combination of PGF3 and PGF1 the constructive length of PGF3 (dimension d) increases by 12.5 mm.

## Installation notes

### Drive

El. motor + pump mounting bracket + coupling + pump

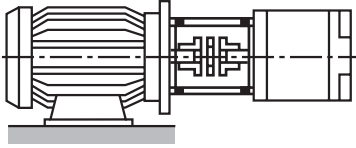

- No radial and axial forces permitted on the pump drive shaft!
- Motor and pump must be exactly aligned!
- Always use a coupling that is suitable for compensating for shaft offsets!
- When installing the coupling, avoid axial forces, that is, **do not hammer or press the coupling onto the shaft!** Use the female thread of the drive shaft!

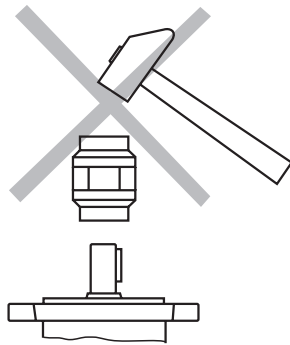

### Installation positions

B3

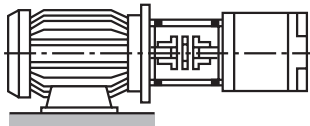

B5

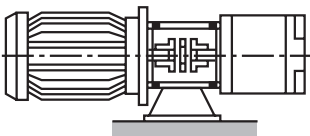

V1

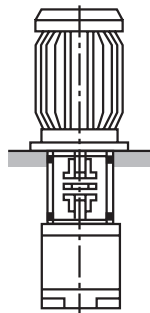

### Fluid tank

- Adjust the useful capacity of the tank to the operating conditions
- The permissible fluid temperature must not be exceeded; if required, provide cooler

### Lines and connections

- Remove protective plug from pump
- We recommend the use of seamless precision steel pipes according to DIN 2391 and pipe connections that can be loosened
- Select the clear width of pipes according to the connections (suction velocity 1 to 1.5 m/s)
- For inlet pressure, see page 5
- Thoroughly clean pipes and fittings before their installation

### Recommendation for piping

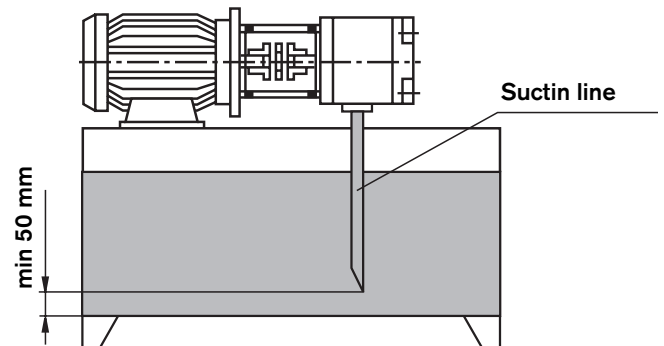

- The returning oil must **under no circumstances** be re-apsed directly, i.e. select the largest possible distance between suction and return line
- The return oil outlet must always be immersed in the oil
- Ensure suction-tight installation of the pipes

### Filters

- If possible, use return line or pressure filters. (Use suction filters only in conjunction with an underpressure switch/clogging indicator)

### Hydraulic fluid

- Please observe our regulations according to data sheet RE 07075
- We recommend the use of branded hydraulic oils
- Different oil grades must not be mixed, since this can result in decomposition and deterioration of the lubricating properties
- The fluid must be changed at certain intervals depending on the operating conditions. This involves cleaning of the fluid tank from residues.

## Commissioning notes

---

### Preparations

- Check whether the system is thoroughly and properly installed.
- Fill the hydraulic fluid only in through filters with the required minimum retention rate.
- Fill the pump completely with hydraulic fluid via the suction or pressure tube.
- Check direction of rotation of the motor for compliance with the direction of rotation according to the pump type.

### Bleeding

- Open the bleeding port of the system by hand or change over to circulation at zero pressure in accordance with the operating instructions of the system. During bleeding, the pressureless transportation of entrapped air must be ensured.
- To bleed the pump, briefly switch the motor on and then switch it immediately off again (inching mode). Repeat this process until the pump is completely bled.
- Close the open bleeding ports by hand.

### Commissioning

- When it is ensured that the pump is completely bled, switch the motor on. Let the pump run at zero pressure until the system is completely bled. For system bleeding, observe the operating instructions for the system.
- Commission the system according to the operating instructions and let pumps run under load.
- After some time in operation, check the hydraulic fluid in the tank for bubbles or foaming on the surface.

### Operation

- During operation, take note of changes in the noise emission. Due to warming up of the operating medium, a slight increase in the noise level is normal. A remarkable increase in the noise level or brief, stochastic changes in the noise characteristics can indicate the aspiration of air. In the case of too short suction pipes or low oil levels of the operating medium, air can also be sucked in through a vortex.
- Changes in the operating velocities, temperatures, increase in noise or power requirement indicate wear or damage to the system or the pump.

### Re-commissioning

- Inspect the pump and system for leakage. Loss of oil indicates leakage below the hydraulic fluid level. An increased hydraulic fluid level in the tank indicates leakage above the hydraulic fluid level.
- When the pump is arranged above the hydraulic fluid level, the pump can drain via leaking points, e.g. a worn-out shaft seal ring. In this case, it must be bled again during re-commissioning. Have the damage repaired.
- After repair and maintenance were carried out, re-bleeding is required.
- Switch the motor on when the system is in flawless condition.

### General

- Pumps delivered by us are tested for function and performance. Never make any changes of whatever nature to the pump, otherwise the warranty will become void!
- Repairs may only be carried out by the manufacturer or his authorised dealers and agencies. Repairs carried out by yourselves will not be covered by the warranty.

### Important notes

- Adjustments, maintenance and repair of the pump may only be carried out by authorised, trained and instructed personnel!
- Use only genuine Rexroth spare parts!
- The pump may only be operated at the permissible data (see pages 4 and 5).
- The pump may only be operated when in perfect condition!
- When carrying out any work on the pump (e.g. installation or removal), the system must be switched off and depressurised!
- Unauthorised conversions or changes that affect safety and function are not permitted!
- Attach protective guards (e.g. coupling protection)!
- Any existing protective guards must not be removed!
- The generally valid safety regulations and regulations for the

## Engineering notes

---

Comprehensive notes and suggestions can be found in The Hydraulic Trainer, Volume 3 RE 00281, "notes on the planning and design of hydraulic systems".

When using internal gear pumps, provide an additional manual, switchable or automatic bleeding option. The bleed point for manual bleeding must be provided in the pressure line upstream of the first valve or check valve in order that bleeding can be carried out at zero pressure.

### Technical data

All technical data given depend on manufacturing tolerances and are valid in conjunction with certain boundary conditions. Please note that certain deviations are therefore possible, and that technical data may vary when boundary conditions (e.g. viscosity) change.

### Characteristic curves

When dimensioning the drive motor, observe the max. permissible operating data on the basis of the characteristic curves shown on pages 6 to 8.

### Noise pressure level

The noise pressure level values shown on pages 6 to 8 were measured in line with DIN 45635, page 26.

This means that only the noise emitted by the pump is shown. Influences by the surroundings (such as place of installation, piping, etc.) were eliminated.

The values always refer to only one pump.

With internal gear pumps, the excitation of valves, pipes, machine parts, etc. is very low due to the low flow pulsation (approx. 2 to 3 %).

Nevertheless, under unfavourable conditions, the noise pressure level at the place of installation of the power unit can be 5 to 10 dB(A) higher than the values of the pump itself.

### Pump combinations

Internal gear pumps of series PGF can be combined to form multi-flow pumps. In this context, please observe the permissible through-drive torques (see engineering aid for multi-flow pumps) as well as the fact that the operating media of the relevant pump stage are not separated by means of shaft seal rings.

### Caution!

The operation of multi-flow pumps with different media is only possible after consultation.

## Notes

---

Bosch Rexroth AG  
Hydraulics  
Zum Eisengießer 1  
97816 Lohr am Main, Germany  
Phone +49 (0) 93 52 / 18-0  
Fax +49 (0) 93 52 / 18-23 58  
documentation@boschrexroth.de  
www.boschrexroth.de

© This document, as well as the data, specifications and other information set forth in it, are the exclusive property of Bosch Rexroth AG. Without their consent it may not be reproduced or given to third parties.

The data specified above only serve to describe the product. No statements concerning a certain condition or suitability for a certain application can be derived from our information. The given information does not release the user from the obligation of own judgement and verification. It must be remembered that our products are subject to a natural process of wear and aging.