



Hydraulic gear pumps and motors

through bore aluminium body

DISPLACEMENTS

From 0.07 in³/rev
(1.07 cm³/rev)
To 5.56 in³/rev
(91.10 cm³/rev)

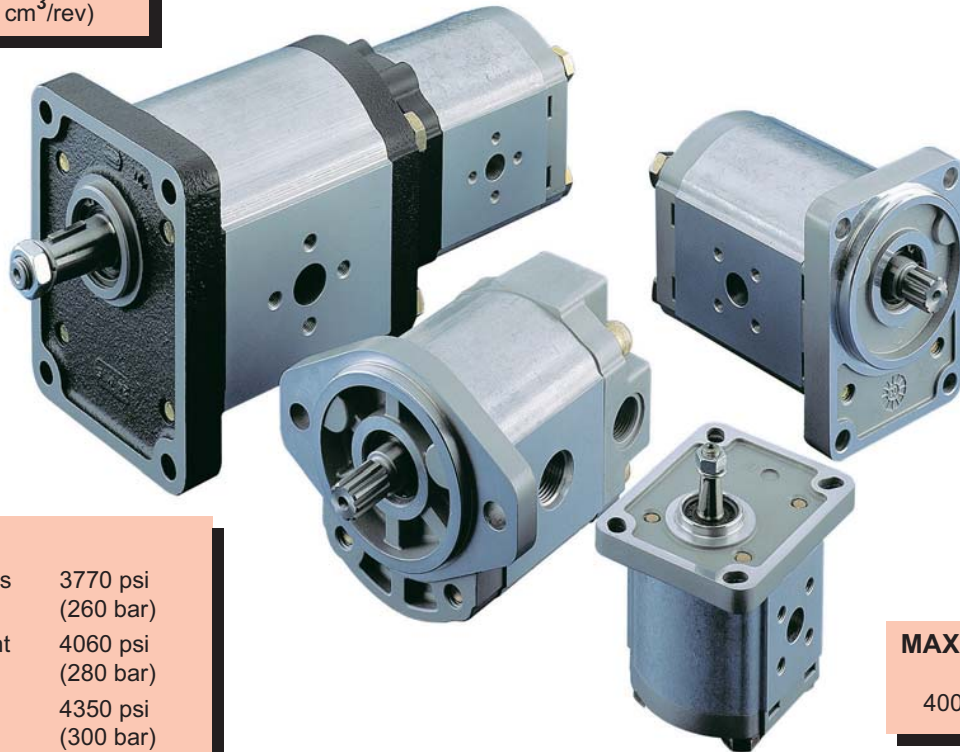

PRESSURE

Max. Continuous 3770 psi
(260 bar)
Max. Intermittent 4060 psi
(280 bar)
Max. Peak 4350 psi
(300 bar)

MAX. SPEED

4000 min⁻¹

- Group 1, 2 and 3 with displacements from 0.07 in³/rev (1,07 cm³/rev) to 5.56 in³/rev (91.10 cm³/rev).
- Drive shafts, mounting flanges and ports according to the international standards.
- Combination of multiple pumps in standard version, common inlet and separated stages.
- Integrated outboard bearings for heavy duty application.
- Many types of built-in valves.

“POLARIS” more than fifty years of Casappa experience in design and production of hydraulic components, characterized by large investments in research and development in order to propose new and personalized solutions to the market. Our use of CAD 3D in the development of this generation permit us the 3D modelling and the virtual simulation of the behaviour of the components inserted in the hydraulic circuit. This means that the process will take less time and the quality of the products is better.

Polaris pumps and motors are basically composed of a gear housing in aluminium alloy, two gear wheels supported by sleeve bearings and two end plates, the front and the rear cover, either in aluminium or in cast iron with excellent mechanical characteristics. Our success is based largely on the quality of our product. This guaranties the consistencies of the efficiencies and low level of noise emission during the life of our products.



INDEX

Section	Page
FEATURES	3
GENERAL DATA PUMPS AND MOTORS	5
PUMPS PERFORMANCE CURVES	7
MOTORS PERFORMANCE CURVES	19
SINGLE UNITS DIMENSION	31
MULTIPLE PUMPS	36
MULTIPLE PUMPS DIMENSION	42
VERSIONS (OUTBOARD BEARINGS FOR SHAFTS)	46
DRIVE SHAFTS	51
MOUNTING FLANGES	57
PORTS	68
CHANGING ROTATION	74
INSTRUCTIONS	75
VALVES AVAILABILITY	76
HOW TO ORDER	77

Replaces: 01/10.03

02/07.2006

○ **Modification from former edition.**

FEATURES

Replaces: 01/10.03

Construction	External gear type pumps and motors
Mounting	EUROPEAN - SAE - GERMAN standard flanges
Line connection	Screw and flange
Direction of rotation (looking on drive shaft)	Anti-clock (S) - clockwise (D) - reversible external drain (L - R) reversible internal drain (B)
Inlet pressure range for pumps	10 ÷ 44 psi [0,7 ÷ 3 bar (abs.)]
Max back pressure for single rotation motors and reversible internal drain motors	p_1 (continuous) max 73 psi (5 bar)
	p_2 (for 20 s) max 116 psi (8 bar)
	p_3 (for 8 s) max 218 psi (15 bar)
Max drain line pressure on the reversible rotation motors	73 psi (5 bar)
Max back pressure on the series motors (reversible motors external drain)	< p_1 (max continuous pressure) < 2175 psi (<150 bar)
Fluid temperature range	See table (1)
Fluid	Mineral oil based hydraulic fluids to ISO/DIN. For other fluids please consult our technical sales department.
Viscosity range	From 60 to 456 SSU [12 to 100 mm ² /s (cSt)] recommended
	Up to 3410 SSU [750 mm ² /s (cSt)] permitted
Filtering requirement	See table (2) page 4

Type	Fluid composition	Max pressure psi - (bar)	Max speed min ⁻¹	Temperature °F - (°C)			Seals (●)	Special shaft seals (◆)
				Min	Max continuous	Max peak		
ISO/DIN	Mineral oil based hydraulic fluid to ISO/DIN	See page 3	See page 3	-13 (-25)	176 (80)	212 (100)	N	D - H - C
				-13 (-25)	230 (110)	257 (125)	V	D

(●) **N**= Buna N (standard) - **V**= Viton

◆ Shaft seals max pressure and mounting scheme

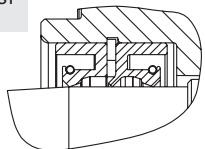
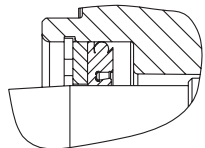
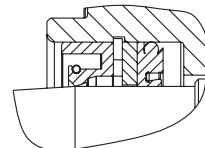
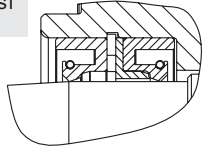
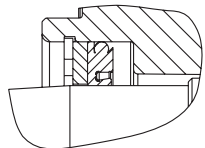
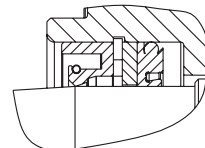
	D	H	C
	Standard shaft seal with wiper seal	High pressure special shaft seal	High pressure special shaft seal with wiper seal
Single rotation pumps	Max 44 psi (3 bar) DCAT_033_037 	Max 363 psi (25 bar) # DCAT_033_039 	Max 363 psi (25 bar) # DCAT_033_036 
Single rotation motors Reversible rotation pumps and motors	Max 44 psi (3 bar) DCAT_033_038 	DCAT_033_039 	DCAT_033_036 

Pressure could change in connection with shaft speed rotation. For more information please consult our technical sales department.

02/07.2006

FEATURES

Filtration

Tab. 2 ●

Working pressure psi (bar)	$\Delta p < 2030$ $\Delta p < (140)$	$2030 < \Delta p < 3045$ $(140) < \Delta p < 210$	$\Delta p > 3045$ $\Delta p > (210)$
Contamination class NAS 1638	10	9	8
Contamination class ISO 4406	21/19/16	20/18/15	19/17/14
Achieved with filter $\beta_{X(c)} \geq 75$	25 μm	10 μm	10 μm

Casappa recommends to use its own production filters:



General notes

Available with different inlet and outlet ports.
For more information please consult our technical sales department.

Definition of rotation direction looking on the drive shaft

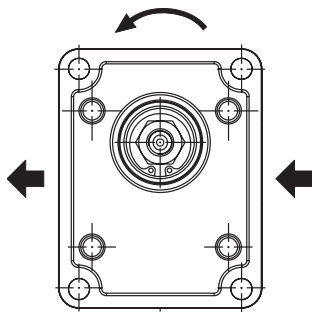

Anti-clock rotation

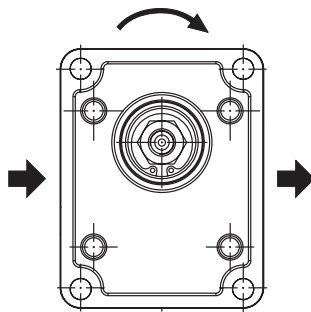

Clockwise rotation

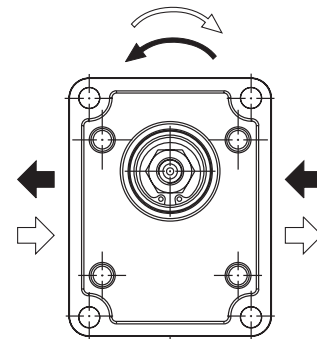

Reversible rotation

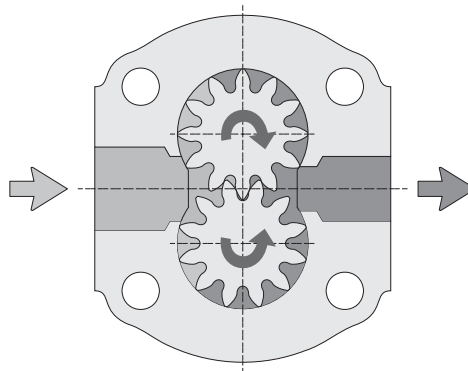

Pressure definition

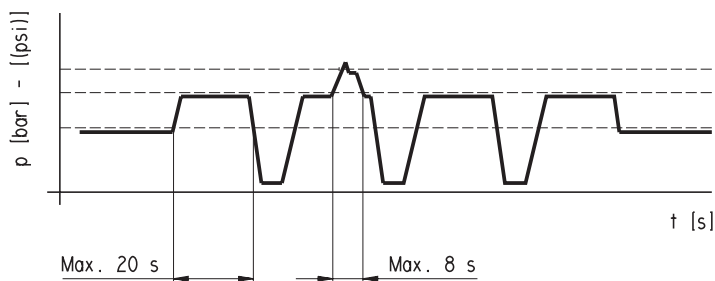

p_1 Max. continuous pressure
 p_2 Max. intermittent pressure
 p_3 Max. peak pressure

Replaces: 01/10.03

● 02/07.2006

GENERAL DATA PUMPS AND MOTORS

Series	Pump type PLP Motor type PLM	Displacement in ³ /rev (cm ³ /rev)	Max. pressure			Max. speed	Min. speed
			p ₁	p ₂	p ₃		
			psi (bar)				
POLARIS 10	PL. 10•1	0.07 (1,07)	3770 (260)	4060 (280)	4205 (290)	4000	650
	PL. 10•1,5	0.10 (1,60)	3770 (260)	4060 (280)	4205 (290)	4000	650
	PL. 10•2	0.13 (2,13)	3770 (260)	4060 (280)	4205 (290)	4000	650
	PL. 10•2,5	0.16 (2,67)	3770 (260)	4060 (280)	4205 (290)	4000	650
	PL. 10•3,15	0.20 (3,34)	3770 (260)	4060 (280)	4205 (290)	4000	650
	PL. 10•4	0.26 (4,27)	3625 (250)	3915 (270)	4060 (280)	4000	650
	PL. 10•5	0.33 (5,34)	3625 (250)	3915 (270)	4060 (280)	4000	650
	PL. 10•5,8	0.38 (6,20)	3335 (230)	3625 (250)	3770 (260)	3500	650
	PL. 10•6,3	0.41 (6,67)	3335 (230)	3625 (250)	3770 (260)	3500	650
	PL. 10•8	0.52 (8,51)	2610 (180)	2900 (200)	3045 (210)	3500	650
	PL. 10•10	0.65 (10,67)	2030 (140)	2320 (160)	2465 (170)	3500	650
POLARIS 20	PL. 20•4	0.30 (4,95)	3625 (250)	4060 (280)	4350 (300)	4000	600
	PL. 20•6,3	0.40 (6,61)	3625 (250)	4060 (280)	4350 (300)	4000	600
	PL. 20•7,2	0.44 (7,29)	3625 (250)	4060 (280)	4350 (300)	4000	600
	PL. 20•8	0.50 (8,26)	3625 (250)	4060 (280)	4350 (300)	3500	600
	PL. 20•9	0.56 (9,17)	3625 (250)	4060 (280)	4350 (300)	3500	600
	PL. 20•10,5	0.66 (10,9)	3625 (250)	4060 (280)	4350 (300)	3500	600
	PL. 20•11,2	0.69 (11,23)	3625 (250)	4060 (280)	4350 (300)	3500	600
	PL. 20•14	0.89 (14,53)	3625 (250)	4060 (280)	4350 (300)	3500	500
	PL. 20•16	1.03 (16,85)	3625 (250)	4060 (280)	4350 (300)	3000	500
	PL. 20•19	1.16 (19,09)	2900 (200)	3190 (220)	3480 (240)	3000	500
	PL. 20•20	1.29 (21,14)	2900 (200)	3190 (220)	3480 (240)	3000	500
	PL. 20•24,5	1.52 (24,84)	2465 (170)	2755 (190)	3045 (210)	2500	500
	PL. 20•25	1.61 (26,42)	2465 (170)	2755 (190)	3045 (210)	2500	500
	PL. 20•27,8	1.72 (28,21)	1885 (130)	2175 (150)	2465 (170)	2000	500
PL. 20•31,5	2.01 (33,03)	1885 (130)	2175 (150)	2465 (170)	2000	500	
POLARIS 30	PL. 30•22	1.34 (21,99)	3625 (250)	3915 (270)	4060 (280)	3000	350
	PL. 30•27	1.63 (26,70)	3625 (250)	3915 (270)	4060 (280)	3000	350
	PL. 30•34	2.11 (34,55)	3480 (240)	3770 (260)	3915 (270)	3000	350
	PL. 30•38	2.40 (39,27)	3480 (240)	3770 (260)	3915 (270)	3000	350
	PL. 30•43	2.68 (43,98)	3335 (230)	3625 (250)	3770 (260)	3000	350
	PL. 30•51	3.16 (51,83)	3045 (210)	3335 (230)	3480 (240)	2500	350
	PL. 30•61	3.74 (61,26)	2755 (190)	3045 (210)	3190 (220)	2500	350
	PL. 30•73	4.50 (73,82)	2465 (170)	2755 (190)	2900 (200)	2500	350
	PL. 30•82	4.98 (81,68)	2320 (160)	2465 (170)	2610 (180)	2200	350
	PL. 30•90	5.56 (91,10)	2175 (150)	2320 (160)	2465 (170)	2200	350

p₁= Max. continuous pressure p₂= Max. intermittent pressure p₃= Max. peak pressure

The values in the table refer to unidirectional pumps and motors.
 Reversible pump and motors max pressures are 15% lower than those shown in table.
 For different working conditions please consult our sales department.

01/10.03

GENERAL DATA PUMPS AND MOTORS

Q	US gpm (l/min)	Flow
M	lbf in (Nm)	Torque
P	HP (kW)	Power
V	in ³ /rev (cm ³ /rev)	Displacement
n	min ⁻¹	Speed
Δp	psi (bar)	Pressure

Efficiencies

		Pumps	Motors
$\eta_v = \eta_v(V, \Delta p, n)$	Volumetric efficiency	(≈ 0,97)	(≈ 0,96)
$\eta_m = \eta_m(V, \Delta p, n)$	Mechanical efficiency	(≈ 0,88)	(≈ 0,85)
$\eta_t = \eta_v \cdot \eta_m$	Overall efficiency	(≈ 0,85)	(≈ 0,82)

DESIGN CALCULATIONS FOR PUMP

$$Q = V(\text{cm}^3/\text{rev}) \cdot \eta_v \cdot n \cdot 10^{-3} \quad [\text{l/min}]$$

$$M = \frac{\Delta p (\text{bar}) \cdot V (\text{cm}^3/\text{rev})}{62,83 \cdot \eta_m} \quad [\text{Nm}]$$

$$P = \frac{\Delta p (\text{bar}) \cdot V (\text{cm}^3/\text{rev}) \cdot n}{600 \cdot 1000 \cdot \eta_t} \quad [\text{kW}]$$

DESIGN CALCULATIONS FOR MOTOR

$$Q = \frac{V (\text{cm}^3/\text{rev}) \cdot n \cdot 10^{-3}}{\eta_v} \quad [\text{l/min}]$$

$$M = \frac{\Delta p (\text{bar}) \cdot V (\text{cm}^3/\text{rev}) \cdot \eta_m}{62,83} \quad [\text{Nm}]$$

$$P = \frac{\Delta p (\text{bar}) \cdot V (\text{cm}^3/\text{rev}) \cdot n \cdot \eta_t}{600 \cdot 1000} \quad [\text{kW}]$$

01/10.03

Note: Diagrams providing approximate selection data will be found on subsequent pages.

POLARIS 10 GEAR PUMPS PERFORMANCE CURVES

PLP 10

PLP 10

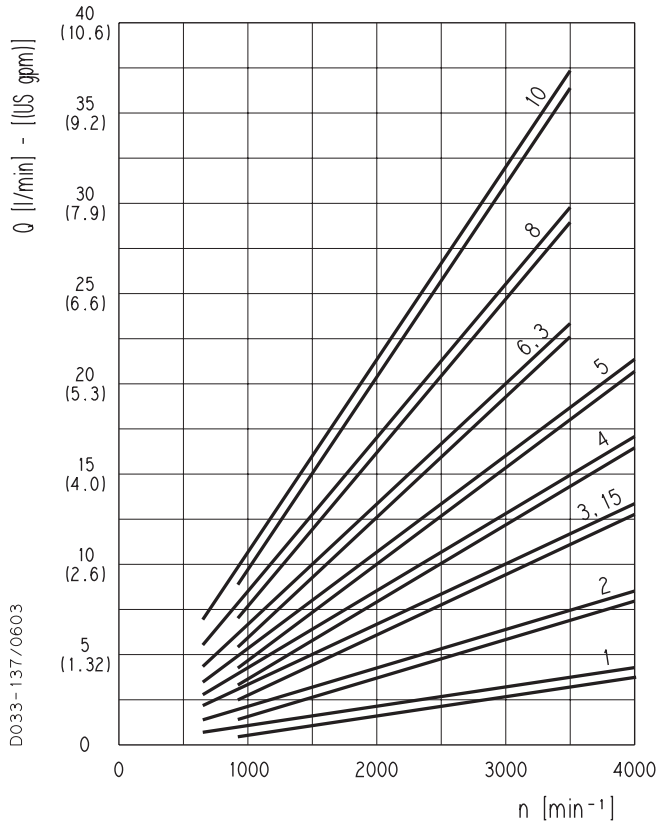

Each curve has been obtained at 122 °F (50°C), using oil with viscosity 168 SSU (36 cSt) at 104 °F (40°C) and at these pressures.

- PLP 10•1 290-3770 psi (20-260 bar)
- PLP 10•2 290-3770 psi (20-260 bar)
- PLP 10•3,15 . . . 290-3770 psi (20-260 bar)
- PLP 10•4 290-3625 psi (20-250 bar)
- PLP 10•5 290-3625 psi (20-250 bar)
- PLP 10•6,3 290-3335 psi (20-230 bar)
- PLP 10•8 290-2610 psi (20-180 bar)
- PLP 10•10 290-2030 psi (20-140 bar)

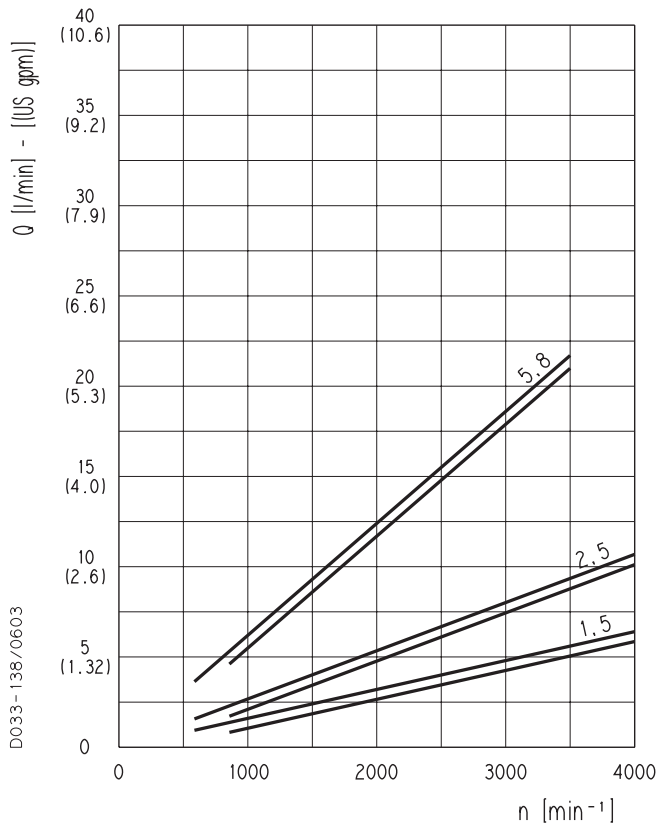

- PLP 10•1,5 290-3770 psi (20-260 bar)
- PLP 10•2,5 290-3770 psi (20-260 bar)
- PLP 10•5,8 290-3335 psi (20-230 bar)

01/10.03

POLARIS 10 GEAR PUMPS PERFORMANCE CURVES

PLP 10

PLP 10•1

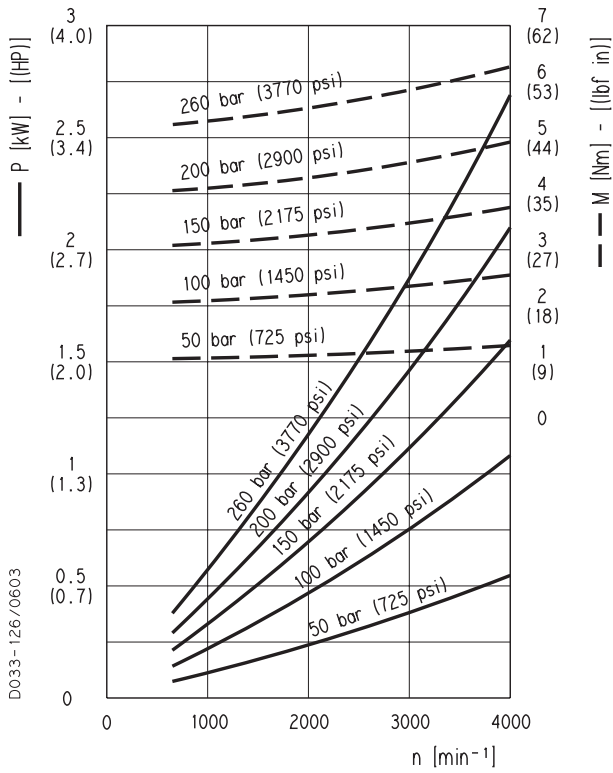

PLP 10•1,5

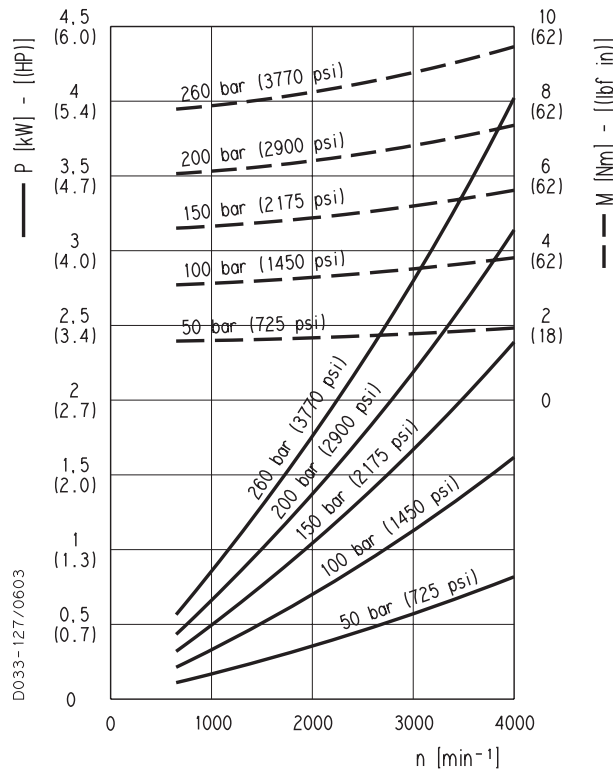

PLP 10•2

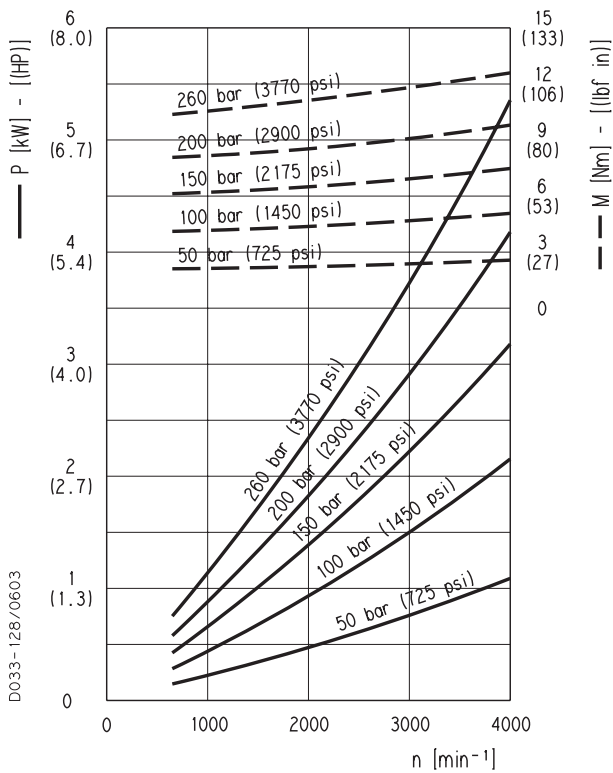

PLP 10•2,5

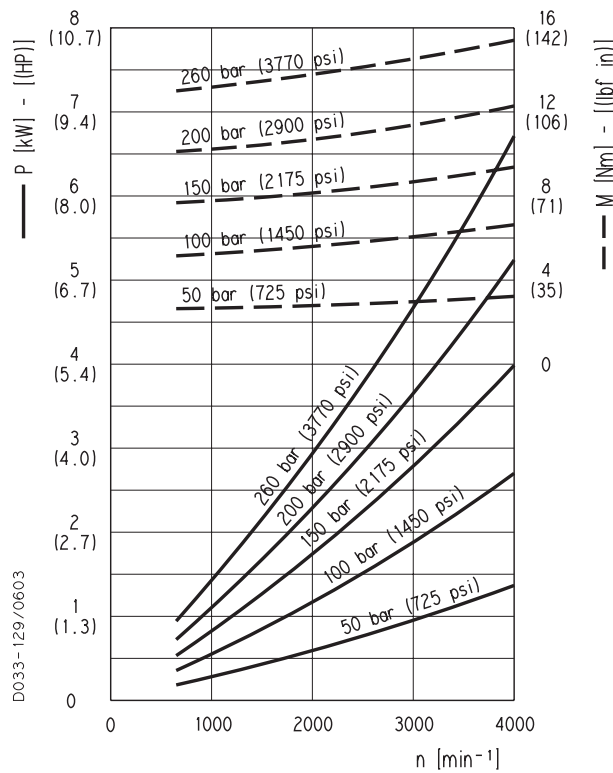

01/10.03

POLARIS 10 GEAR PUMPS PERFORMANCE CURVES

PLP 10

PLP 10•3,15

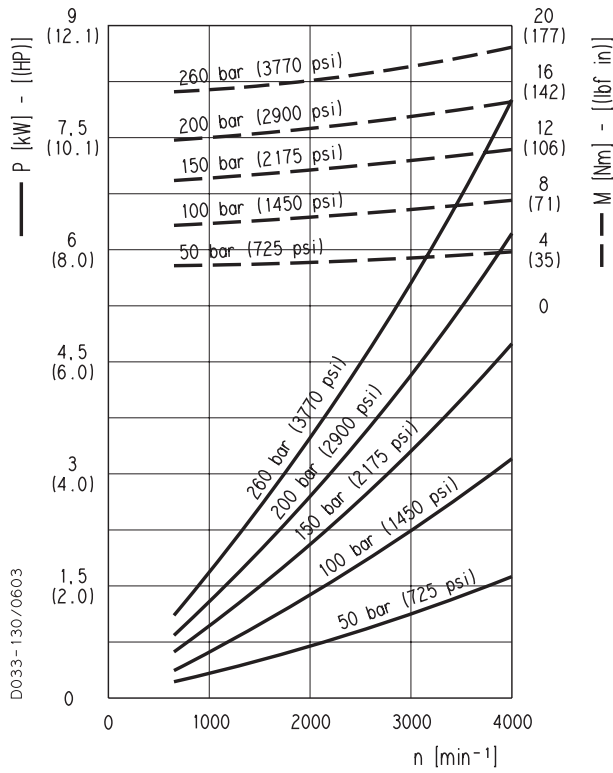

PLP 10•4

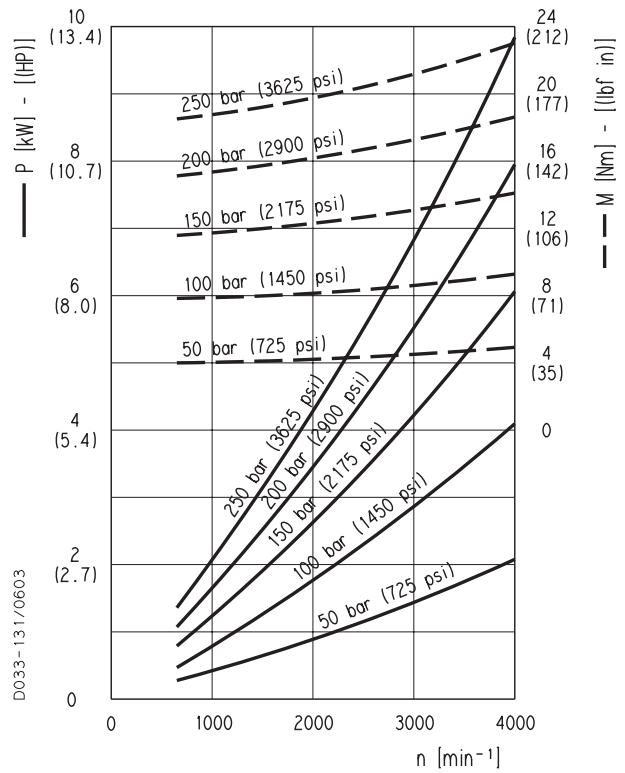

PLP 10•5

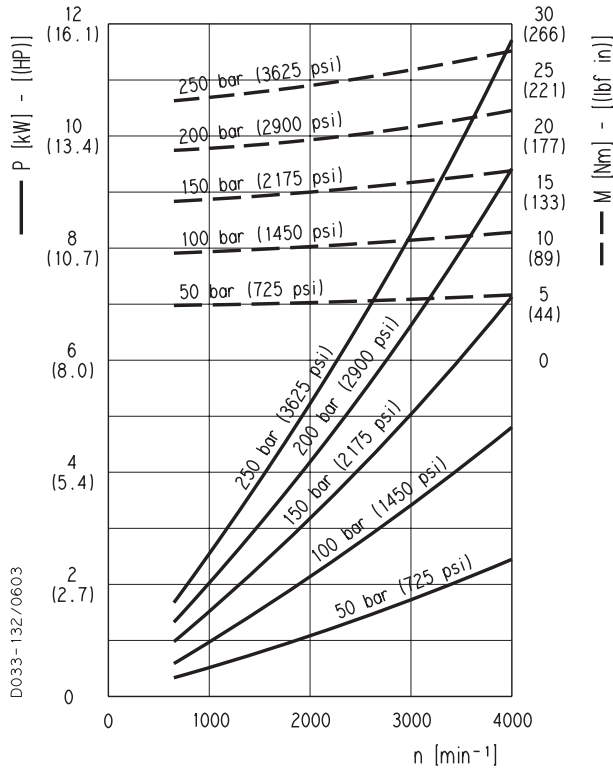

PLP 10•5,8

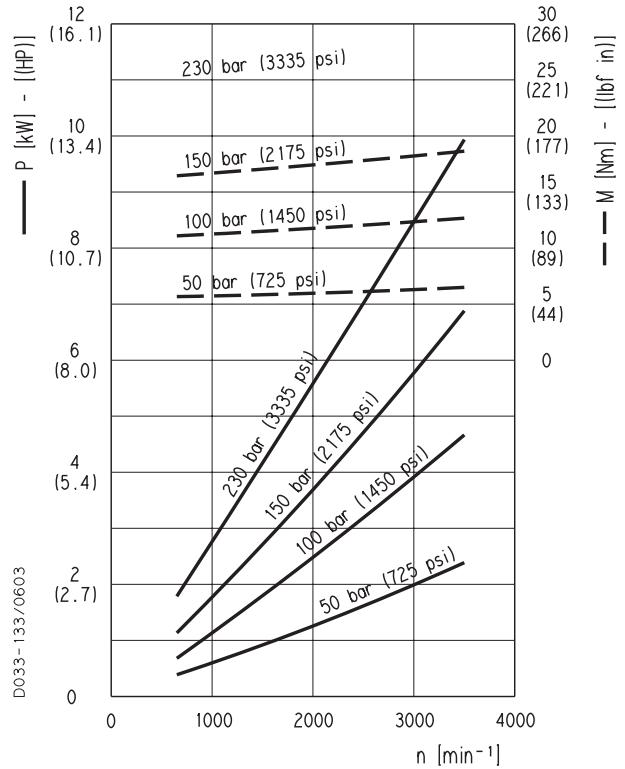

01/10.03

POLARIS 10 GEAR PUMPS PERFORMANCE CURVES

PLP 10

PLP 10•6,3

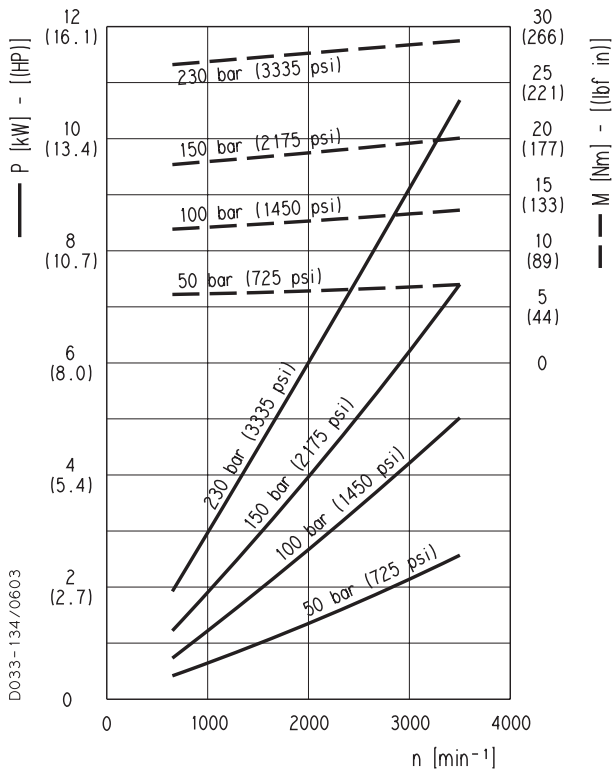

PLP 10•8

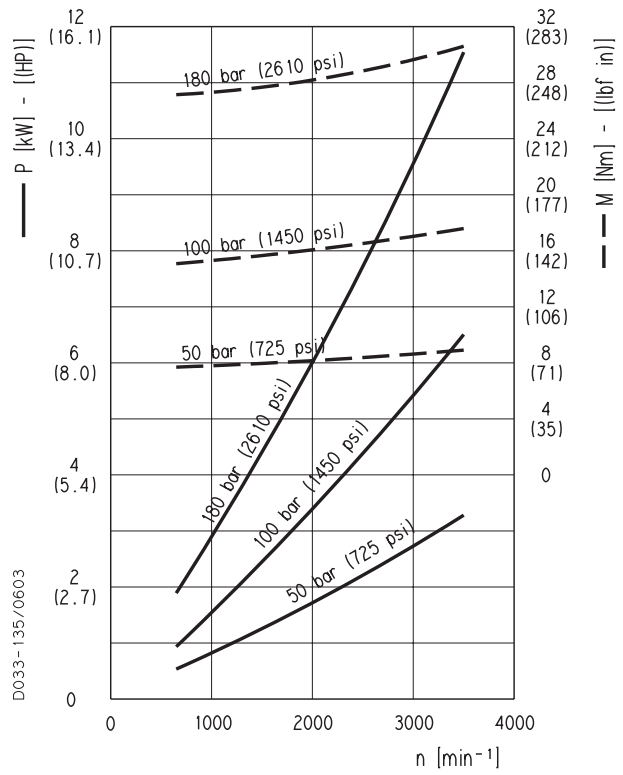

PLP 10•10

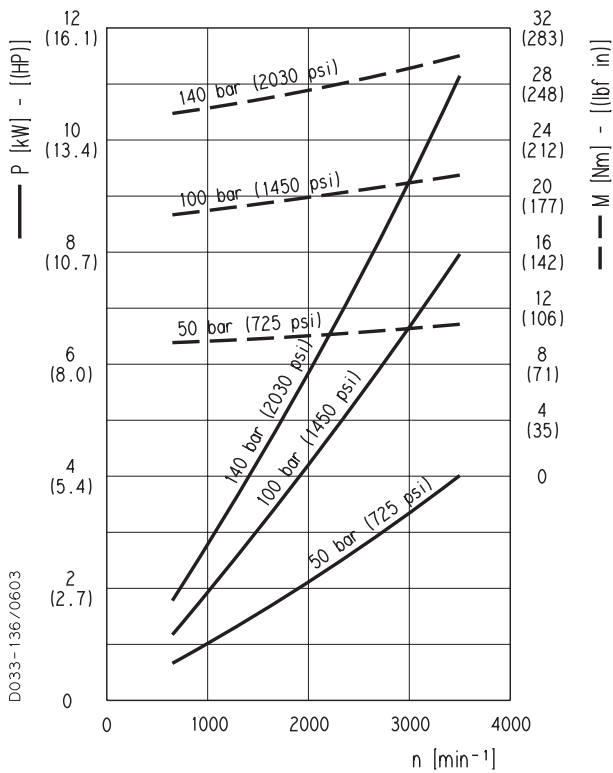

01/10.03

POLARIS 20 GEAR PUMPS PERFORMANCE CURVES

PLP 20

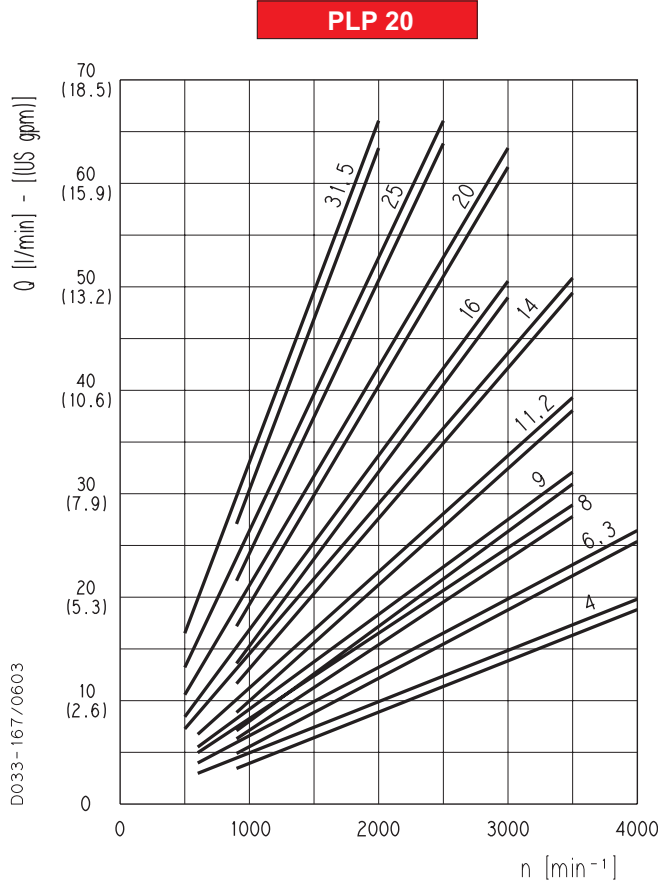

Each curve has been obtained at 122 °F (50°C), using oil with viscosity 168 SSU (36 cSt) at 104 °F (40°C) and at these pressures.

- PLP 20•4 290-3625 psi (20-250 bar)
- PLP 20•6,3 290-3625 psi (20-250 bar)
- PLP 20•8 290-3625 psi (20-250 bar)
- PLP 20•9 290-3625 psi (20-250 bar)
- PLP 20•11,2 290-3625 psi (20-250 bar)
- PLP 20•14 290-3625 psi (20-250 bar)
- PLP 20•16 290-3625 psi (20-250 bar)
- PLP 20•20 290-2900 psi (20-200 bar)
- PLP 20•25 290-2465 psi (20-170 bar)
- PLP 20•31,5 290-1885 psi (20-130 bar)

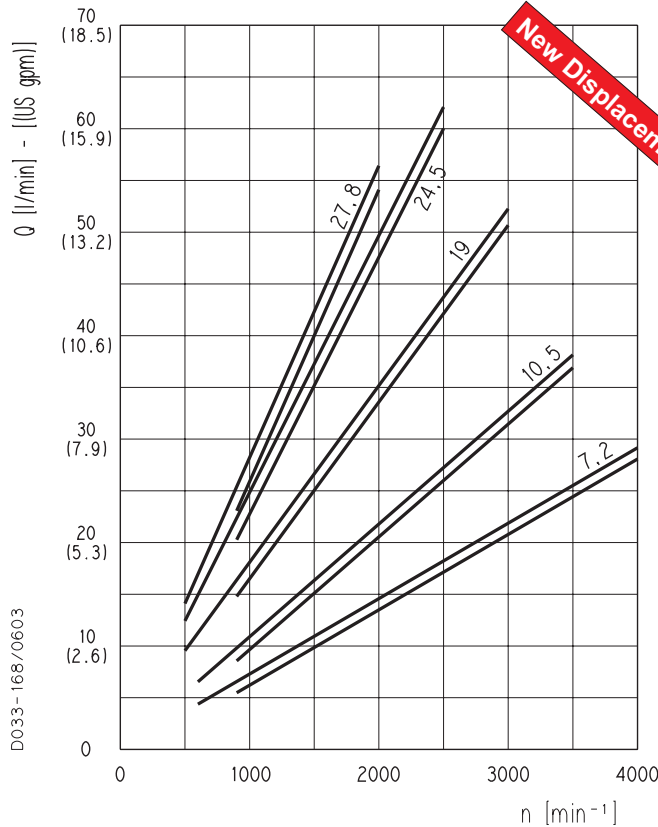

- PLP 20•7,2 290-3625 psi (20-250 bar)
- PLP 20•10,5 290-3625 psi (20-250 bar)
- PLP 20•19 290-2900 psi (20-200 bar)
- PLP 20•24,5 290-2465 psi (20-170 bar)
- PLP 20•27,8 290-1885 psi (20-130 bar)

01/10.03

POLARIS 20 GEAR PUMPS PERFORMANCE CURVES

PLP 20

PLP 20-4

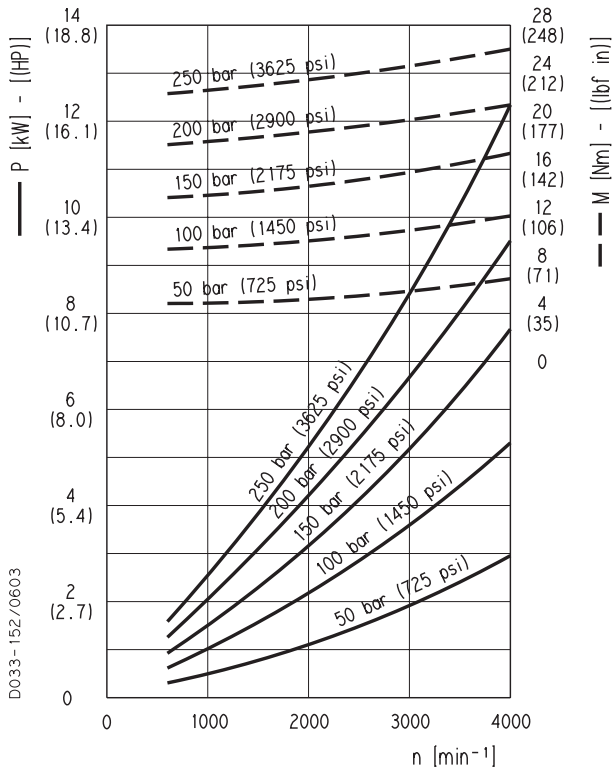

PLP 20-6,3

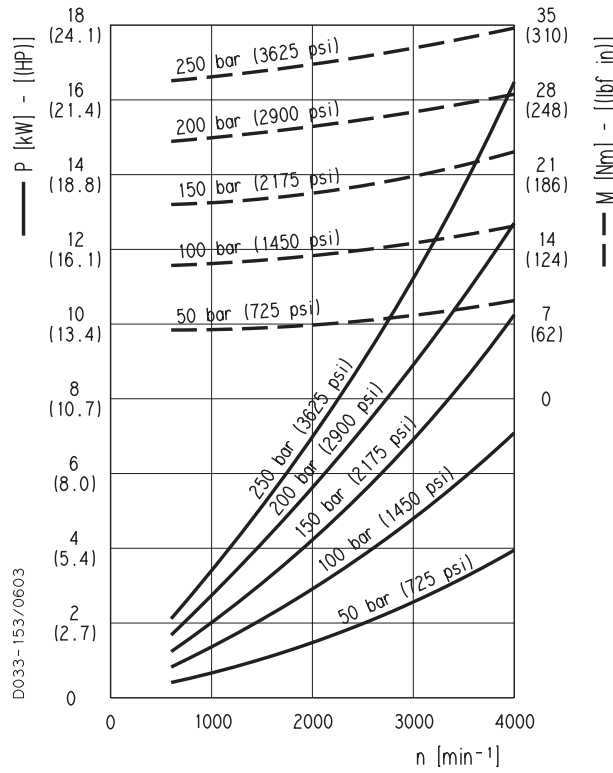

PLP 20-7,2

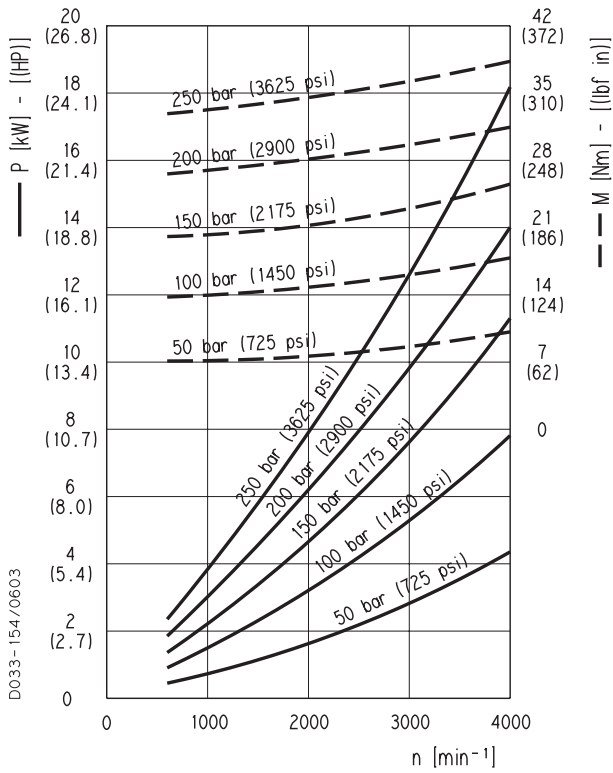

PLP 20-8

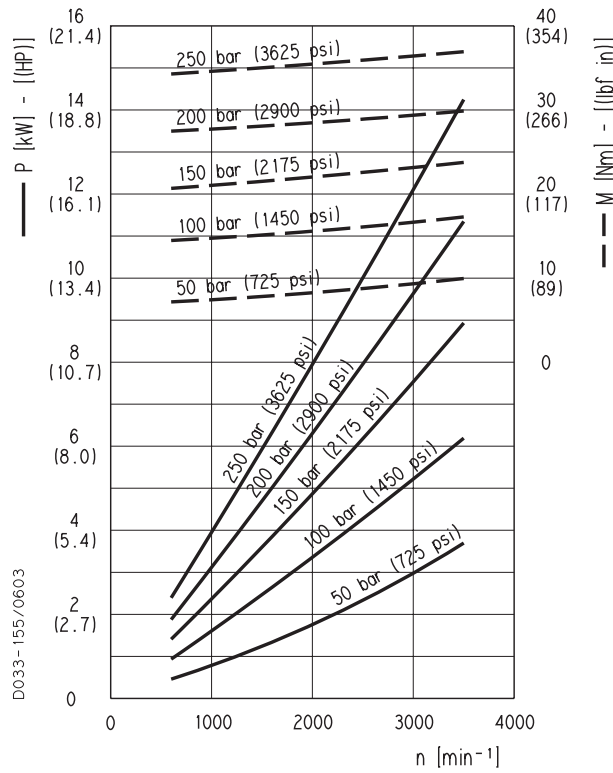

01/10.03

POLARIS 20 GEAR PUMPS PERFORMANCE CURVES

PLP 20

PLP 20•9

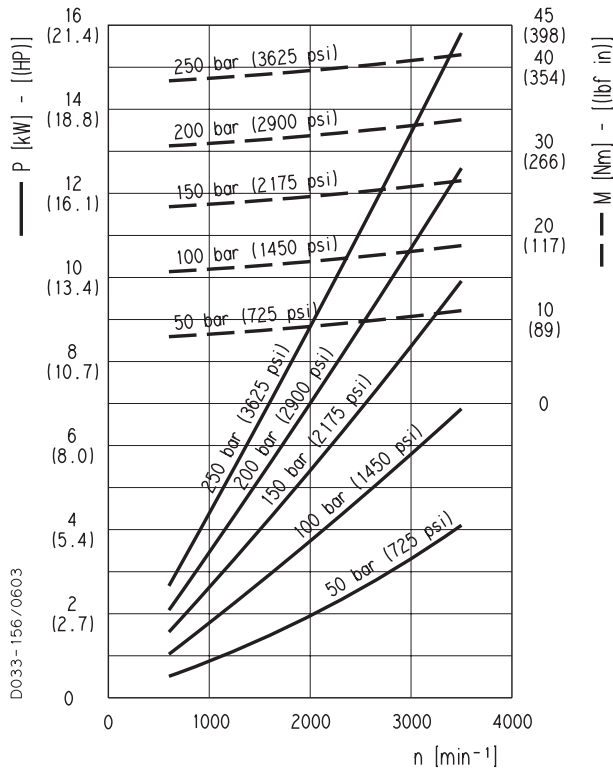

PLP 20•10,5

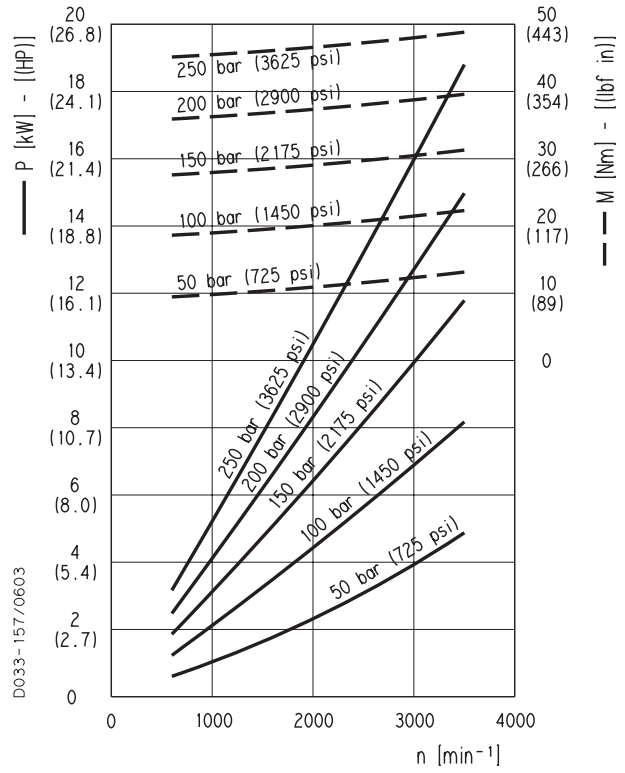

PLP 20•11,2

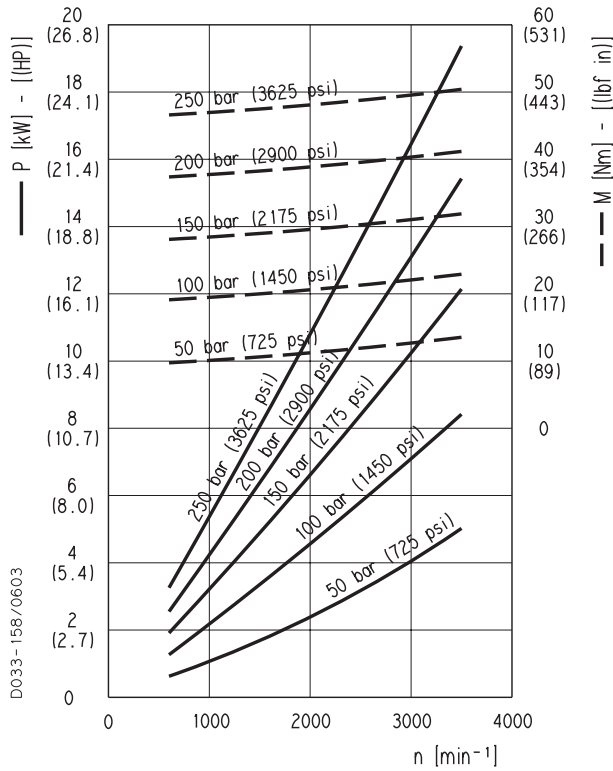

PLP 20•14

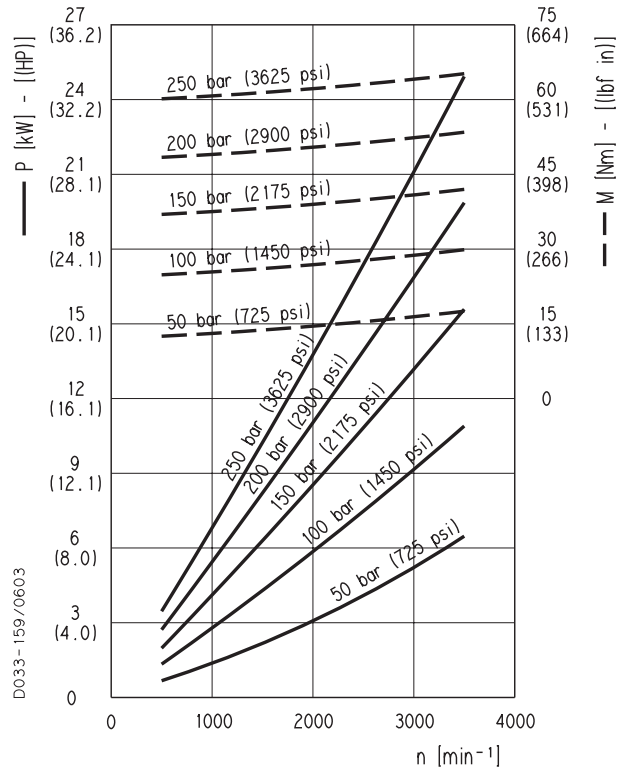

01/10.03

POLARIS 20 GEAR PUMPS PERFORMANCE CURVES

PLP 20

PLP 20•16

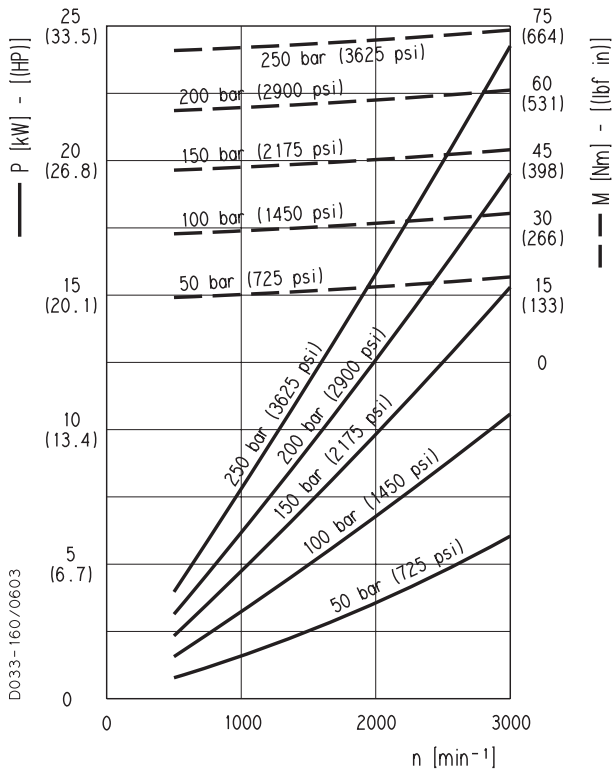

PLP 20•19

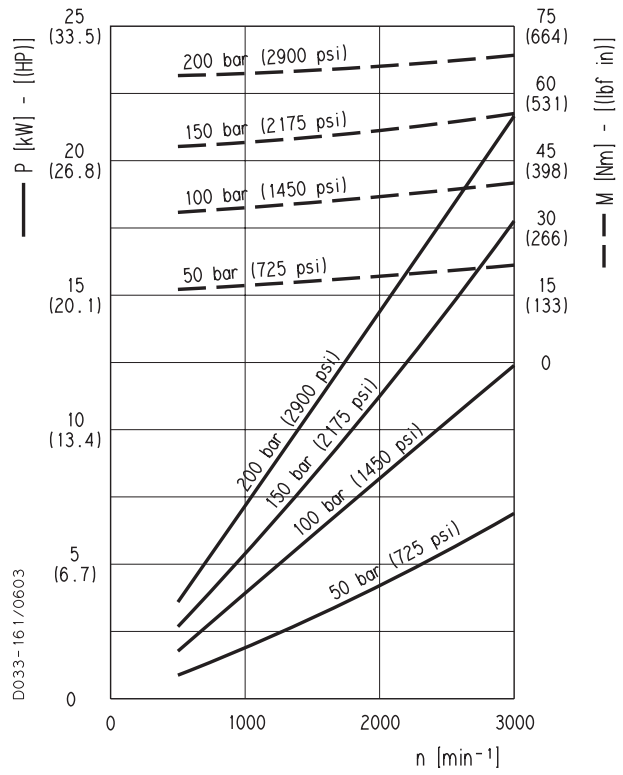

PLP 20•20

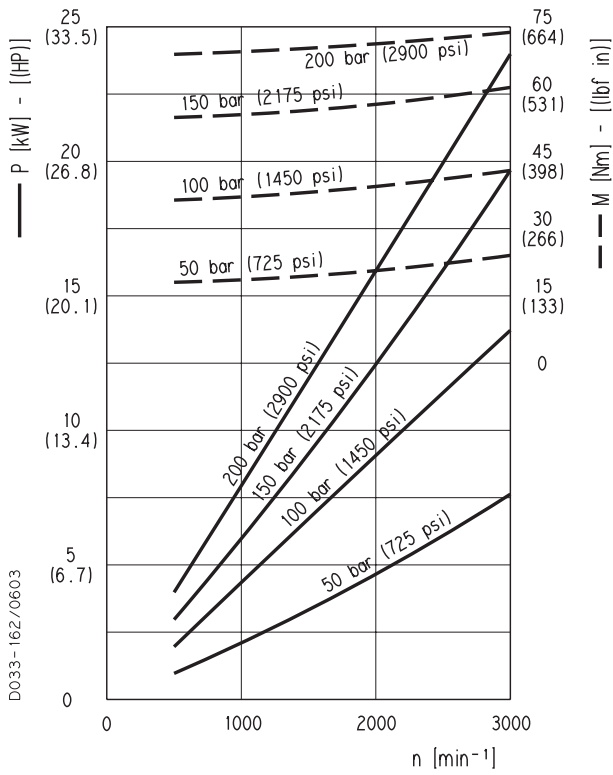

PLP 20•24,5

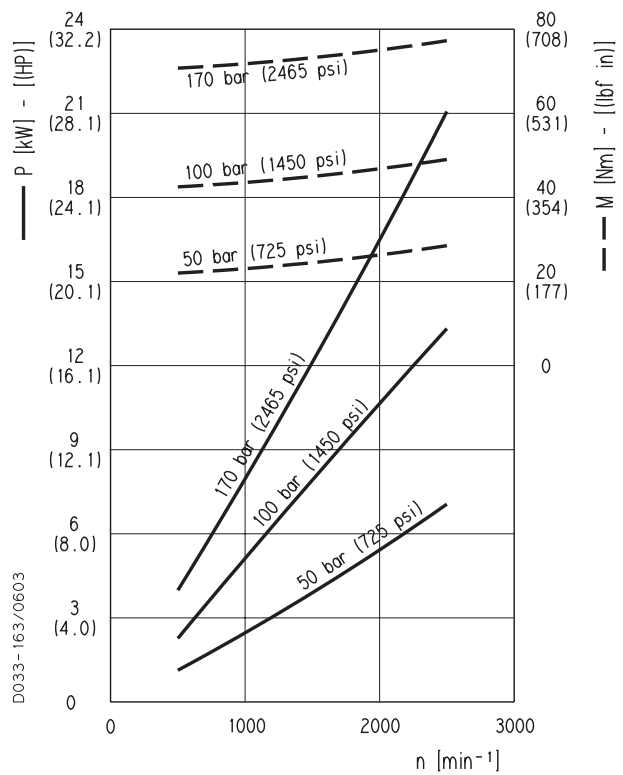

01/10.03

POLARIS 20 GEAR PUMPS PERFORMANCE CURVES

PLP 20

PLP 20•25

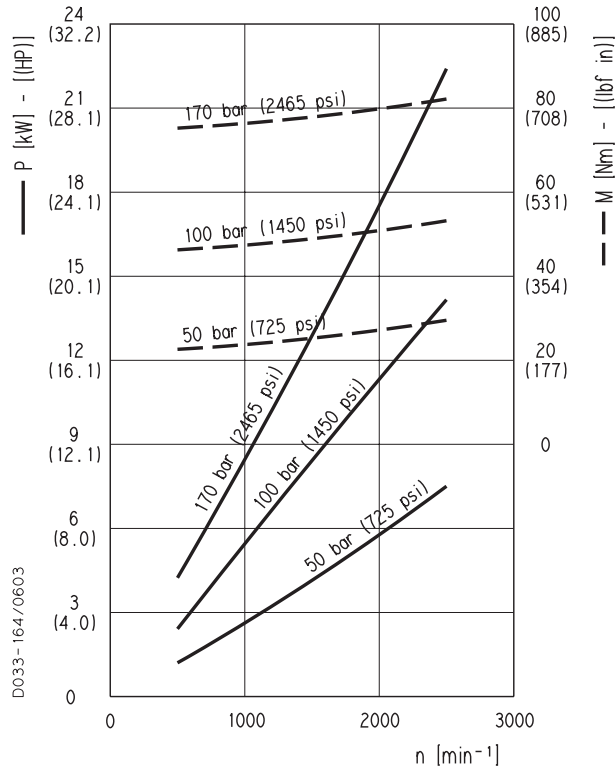

PLP 20•27,8

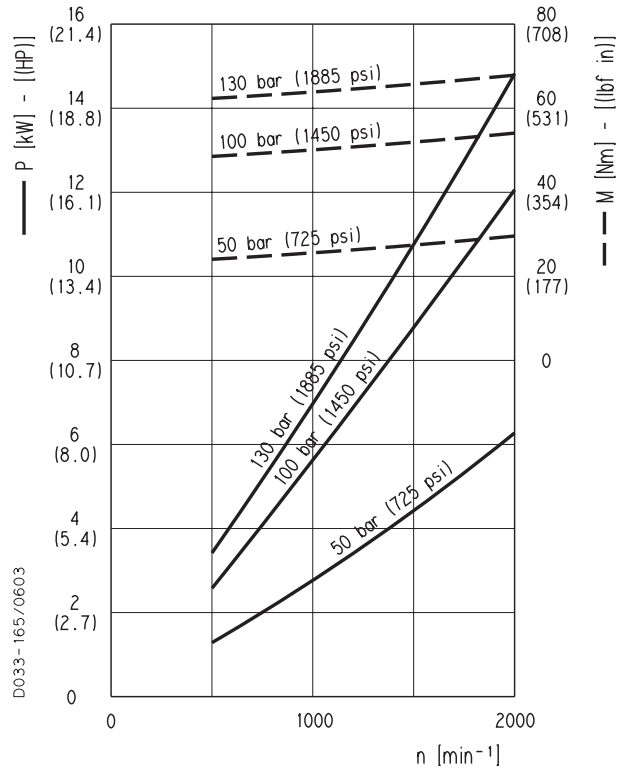

PLP 20•31,5

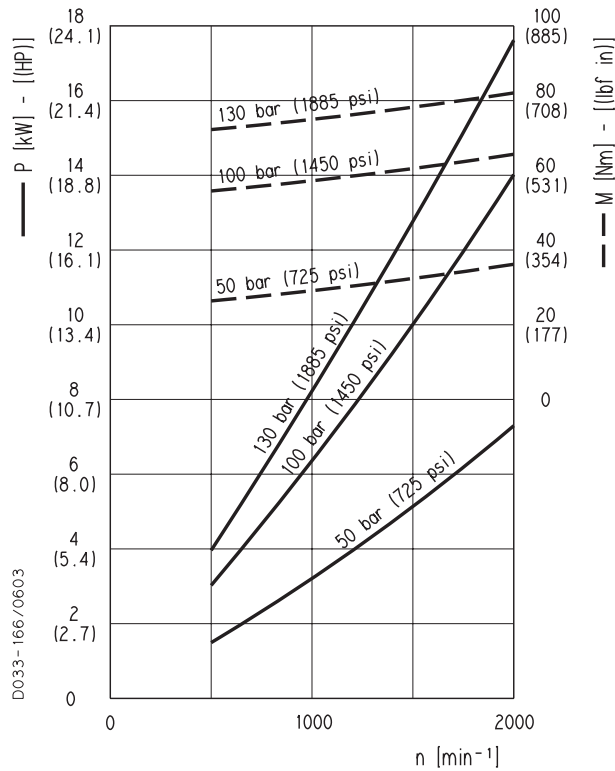

01/10.03

POLARIS 30 GEAR PUMPS PERFORMANCE CURVES

PLP 30

PLP 30

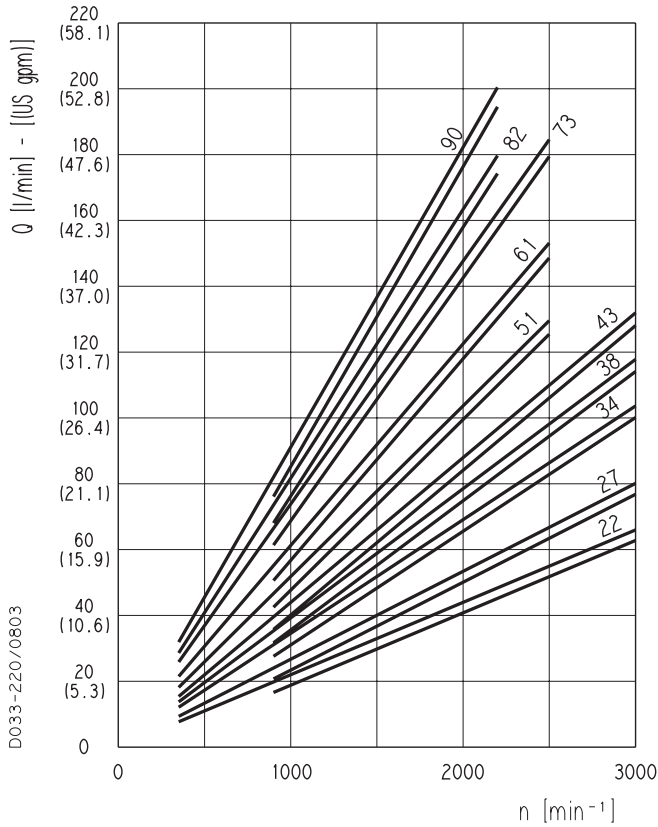

Each curve has been obtained at 122 °F (50°C), using oil with viscosity 168 SSU (36 cSt) at 104 °F (40°C) and at these pressures.

- PLP 30•22 290-3625 psi (20-250 bar)
- PLP 30•27 290-3625 psi (20-250 bar)
- PLP 30•34 290-3480 psi (20-240 bar)
- PLP 30•38 290-3480 psi (20-240 bar)
- PLP 30•43 290-3335 psi (20-230 bar)
- PLP 30•51 290-3045 psi (20-210 bar)
- PLP 30•61 290-2775 psi (20-190 bar)
- PLP 30•73 290-2465 psi (20-170 bar)
- PLP 30•82 290-2320 psi (20-160 bar)
- PLP 30•90 290-2175 psi (20-150 bar)

PLP 30•22

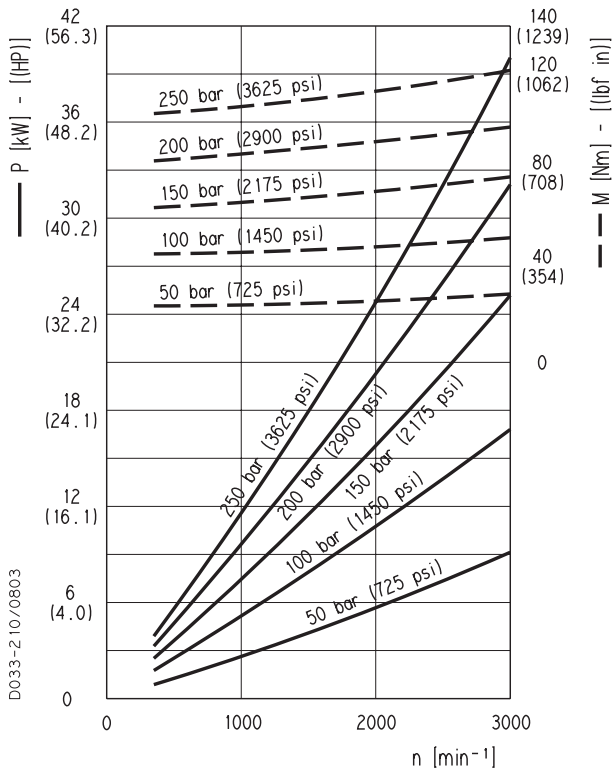

PLP 30•27

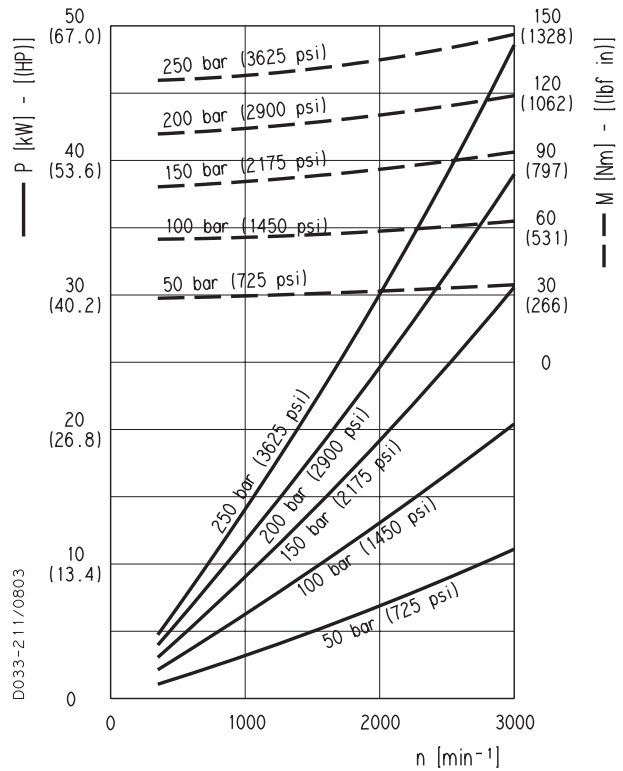

01/10.03

POLARIS 30 GEAR PUMPS PERFORMANCE CURVES

PLP 30

PLP 30-34

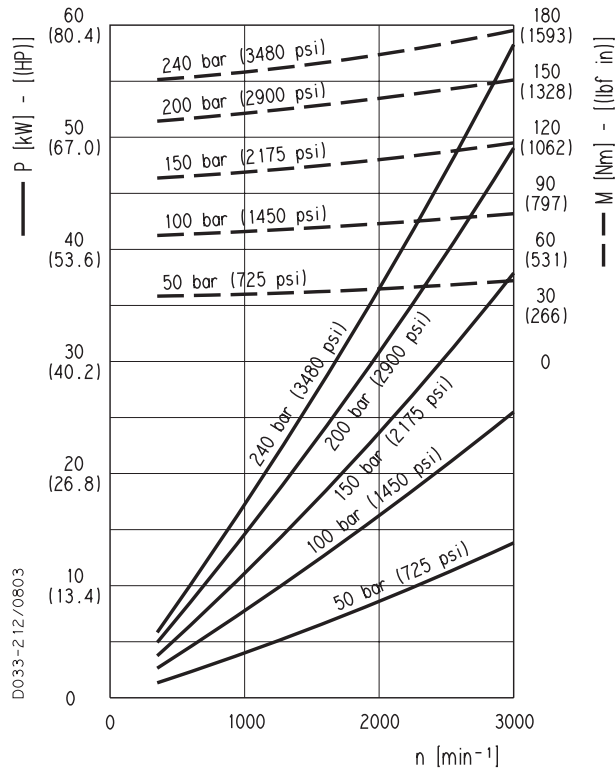

PLP 30-38

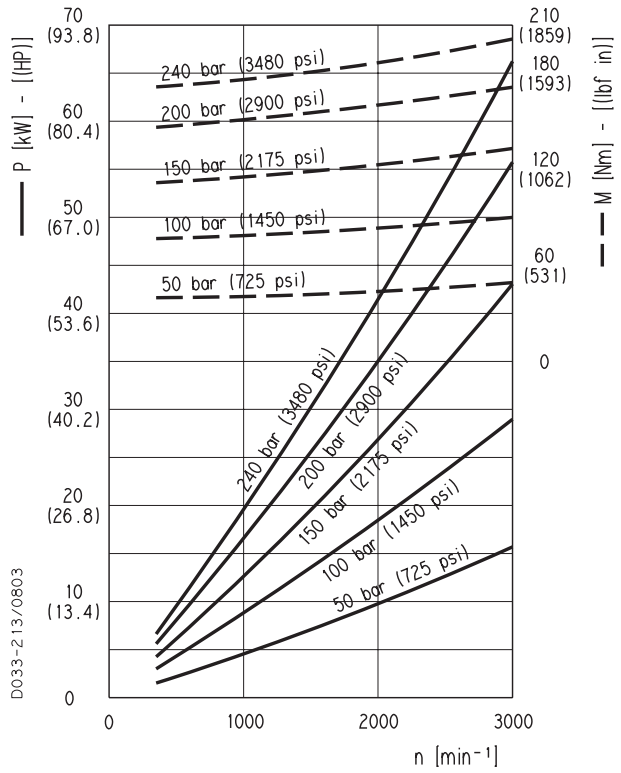

PLP 30-43

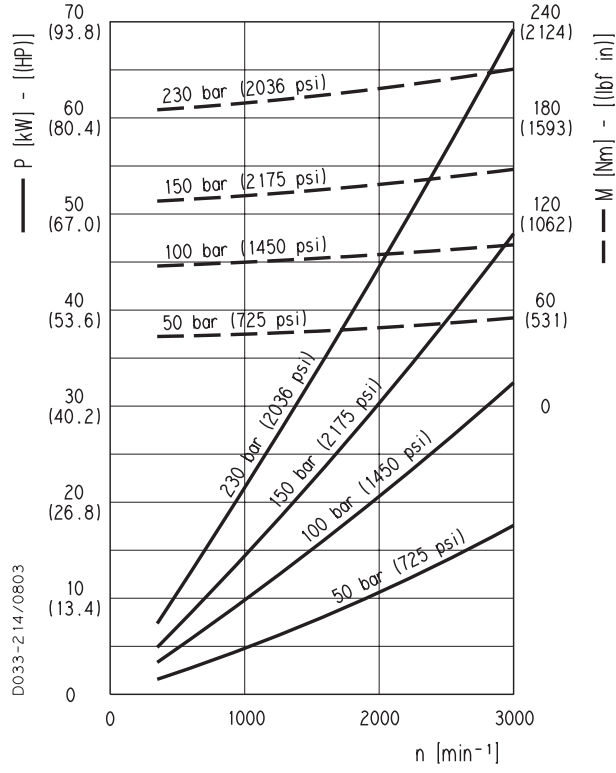

PLP 30-51

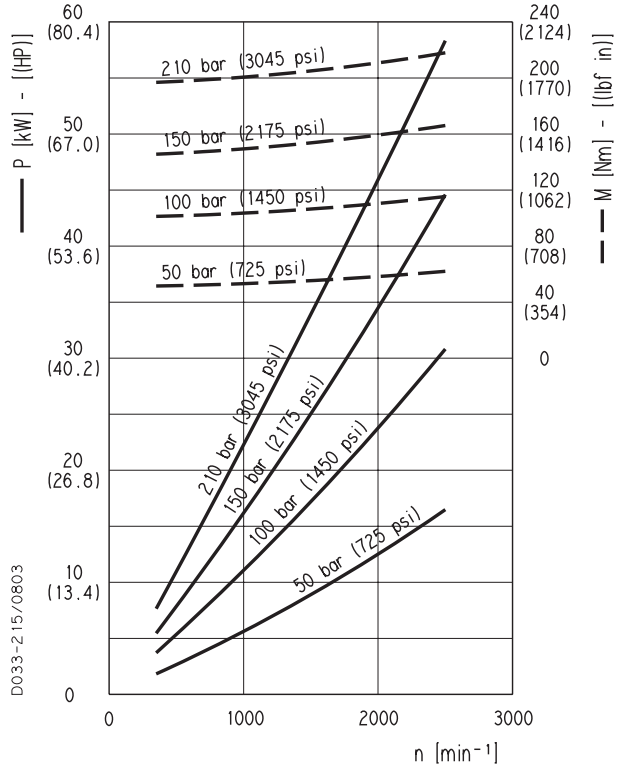

01/10.03

POLARIS 30 GEAR PUMPS PERFORMANCE CURVES

PLP 30

PLP 30-61

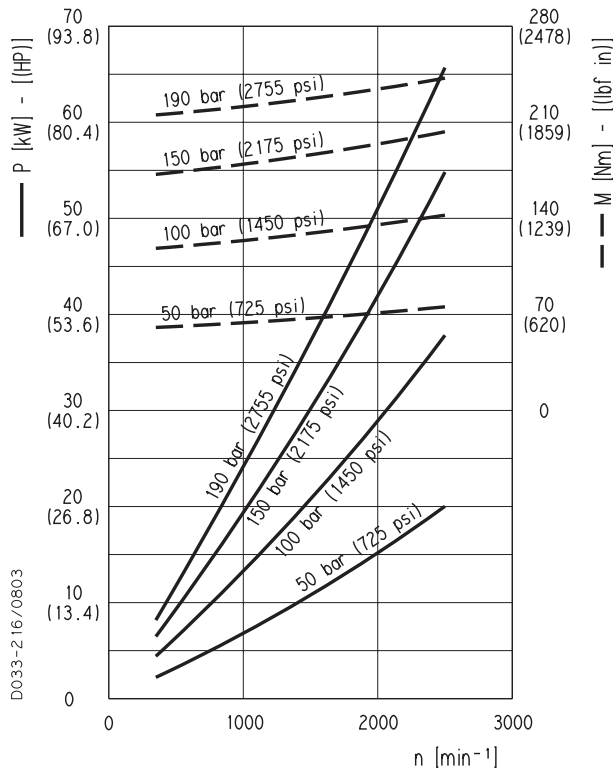

PLP 30-73

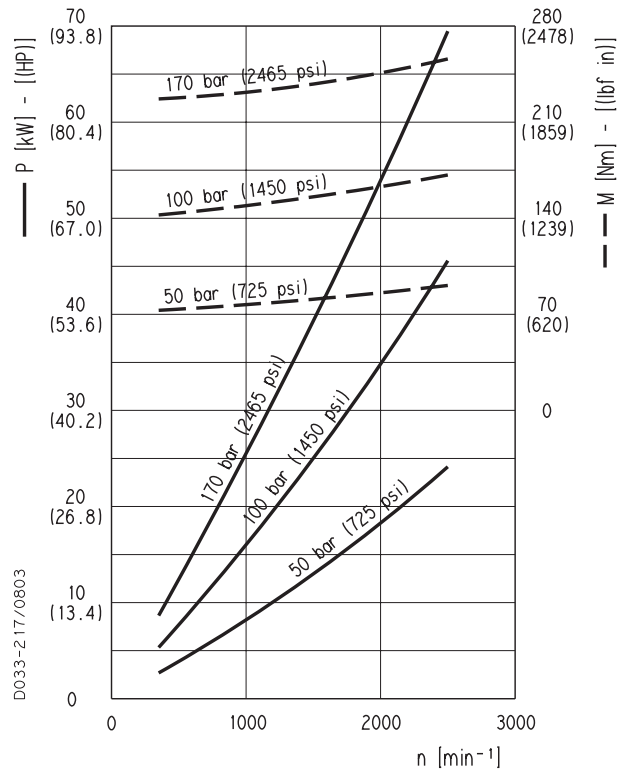

PLP 30-82

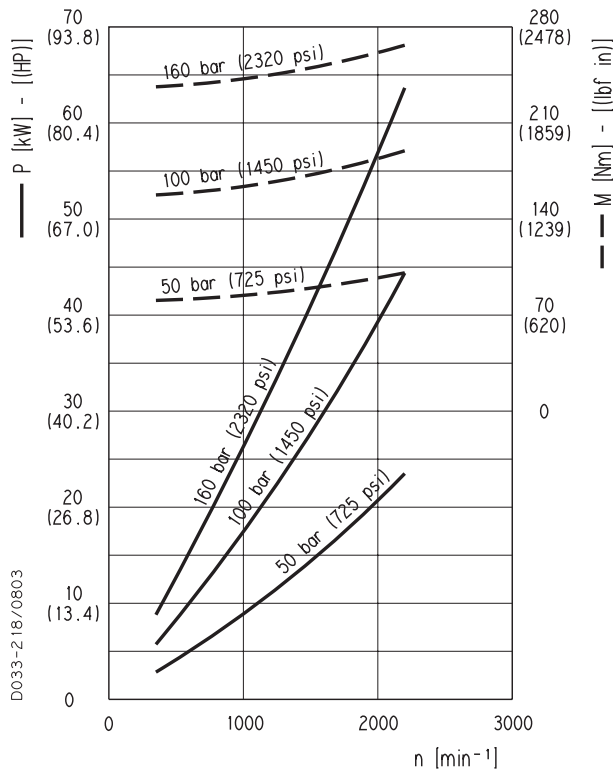

PLP 30-90

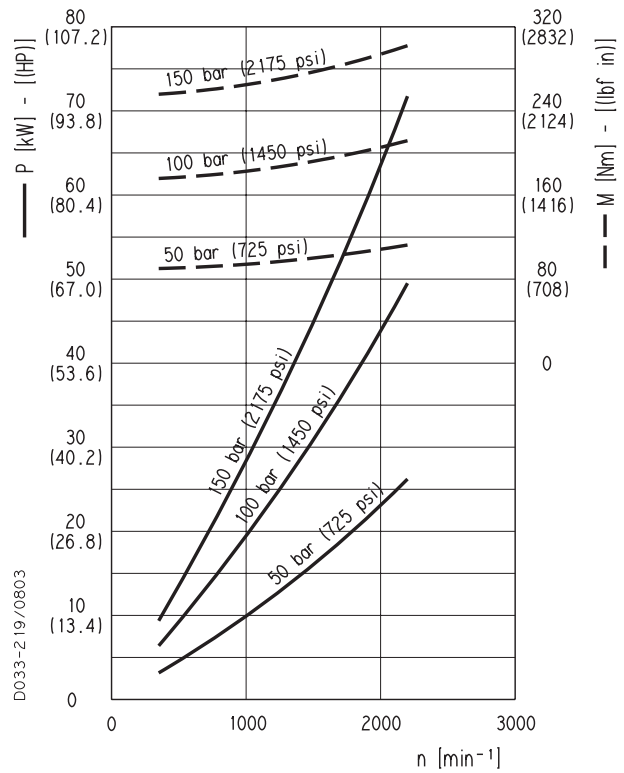

01/10.03

POLARIS 10 GEAR MOTORS PERFORMANCE CURVES

PLM 10

PLM 10

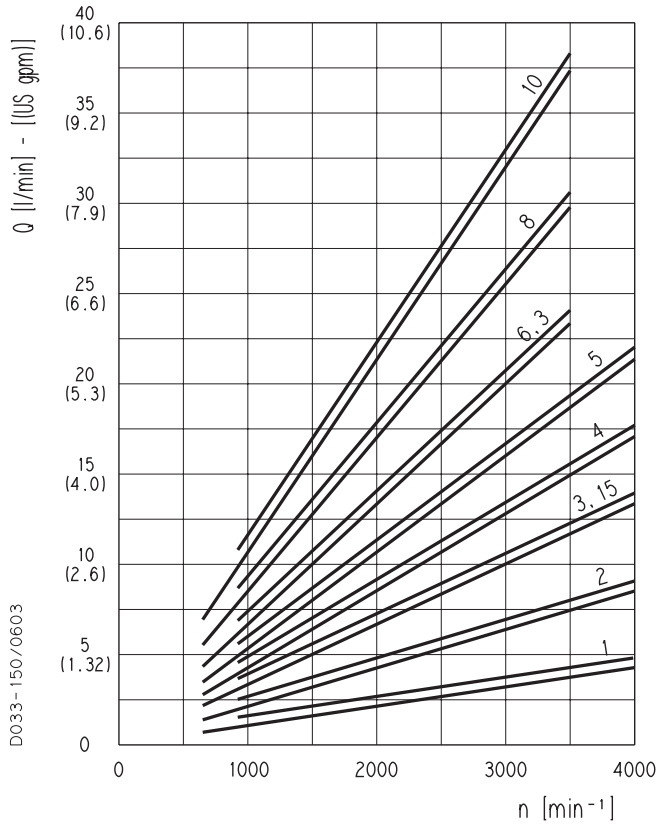

Each curve has been obtained at 122 °F (50°C), using oil with viscosity 168 SSU (36 cSt) at 104 °F (40°C) and at these pressures.

- PLM 10•1 290-3770 psi (20-260 bar)
- PLM 10•2 290-3770 psi (20-260 bar)
- PLM 10•3,15 . . 290-3770 psi (20-260 bar)
- PLM 10•4 290-3625 psi (20-250 bar)
- PLM 10•5 290-3625 psi (20-250 bar)
- PLM 10•6,3 . . . 290-3335 psi (20-230 bar)
- PLM 10•8 290-2610 psi (20-180 bar)
- PLM 10•10 . . . 290-2030 psi (20-140 bar)

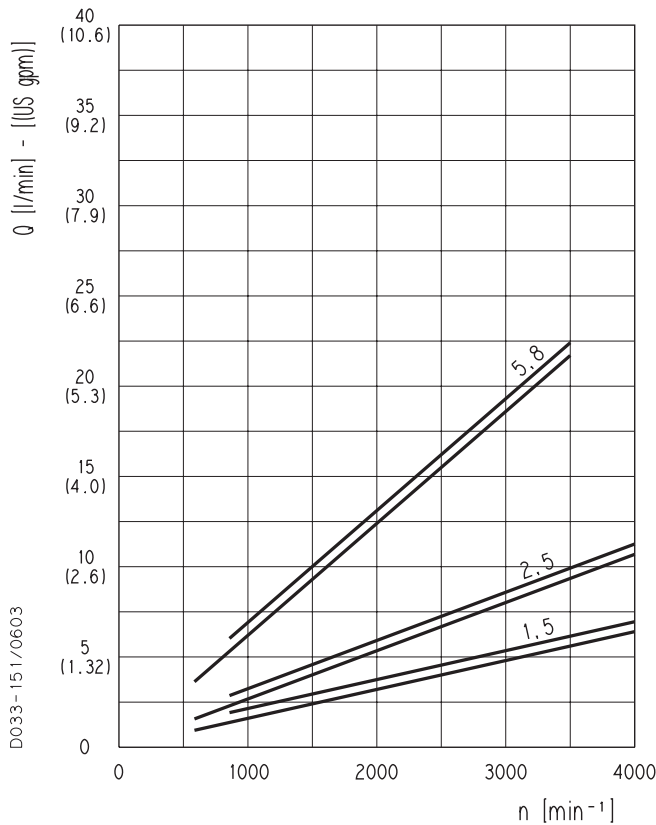

- PLM 10•1,5 . . . 290-3770 psi (20-260 bar)
- PLM 10•2,5 . . . 290-3770 psi (20-260 bar)
- PLM 10•5,8 . . . 290-3335 psi (20-230 bar)

01/10.03

POLARIS 10 GEAR MOTORS PERFORMANCE CURVES

PLM 10

PLM 10-1

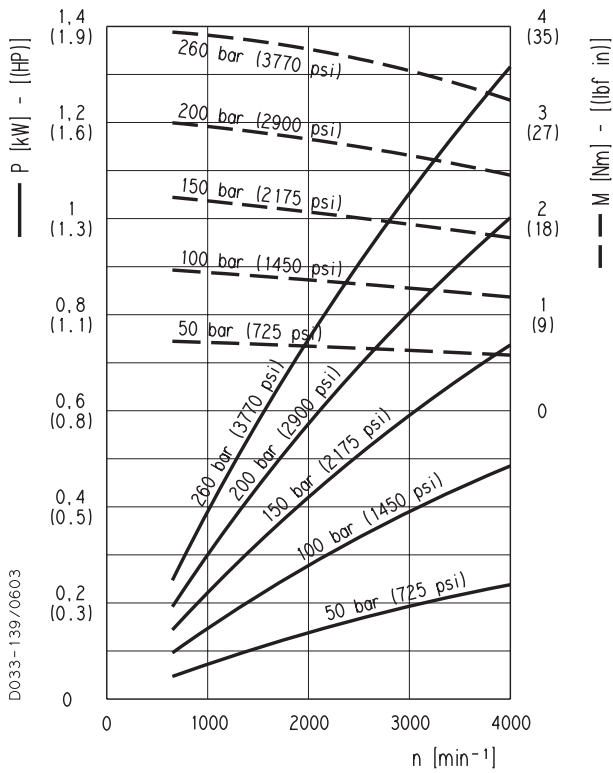

PLM 10-1,5

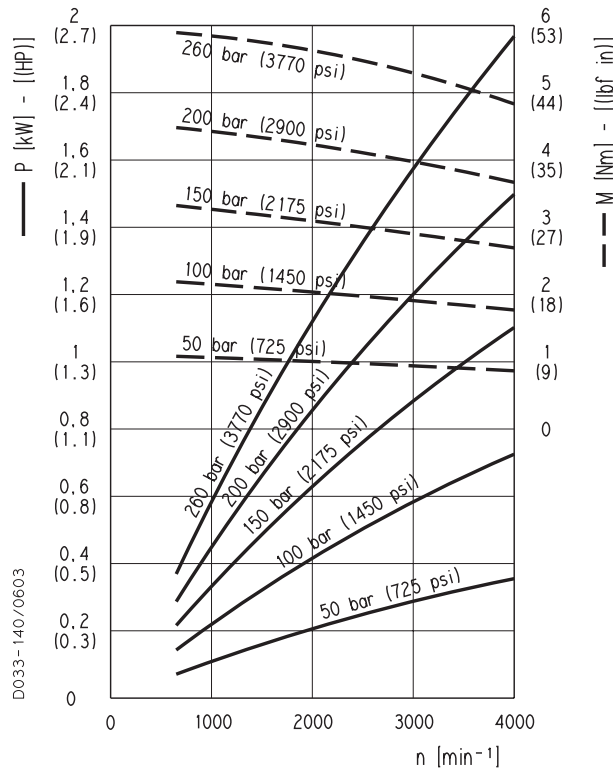

PLM 10-2

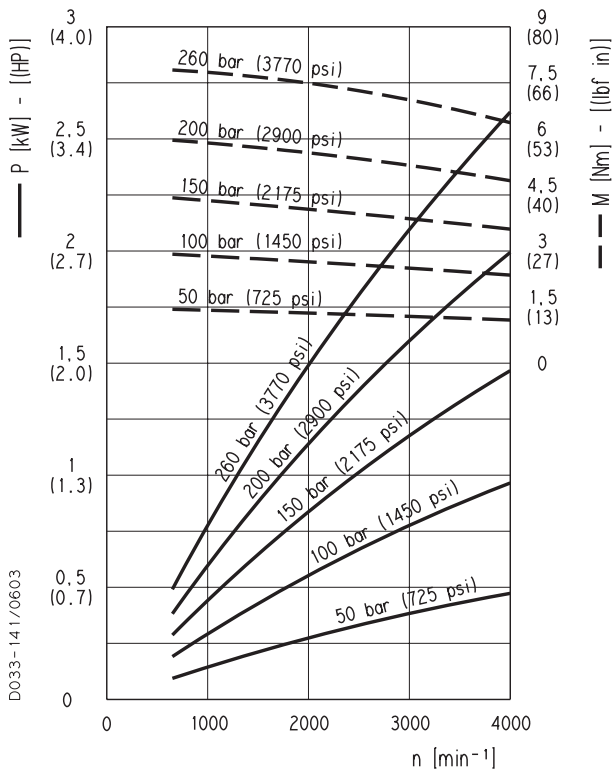

PLM 10-2,5

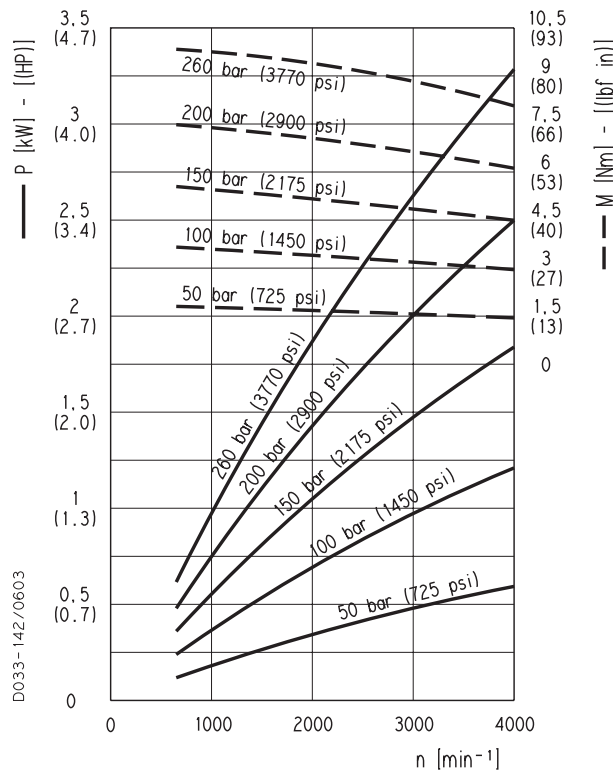

01/10.03

POLARIS 10 GEAR MOTORS PERFORMANCE CURVES

PLM 10

PLM 10•3,15

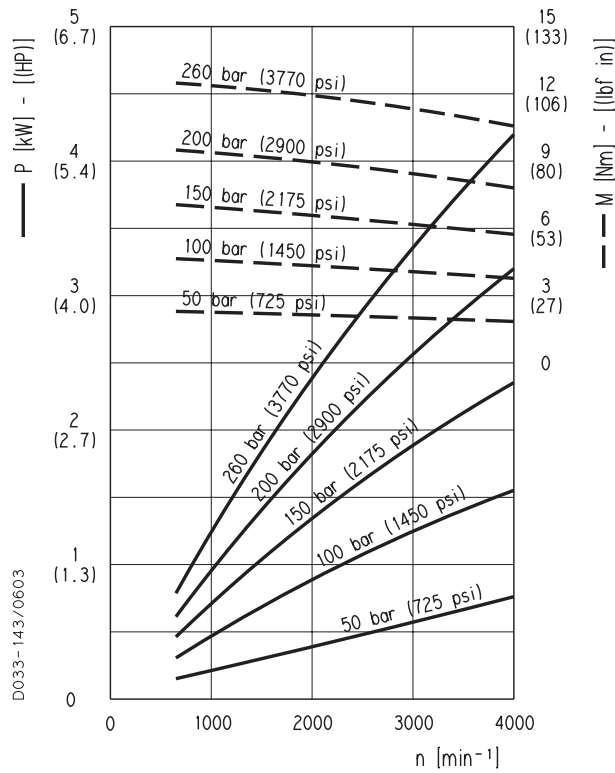

PLM 10•4

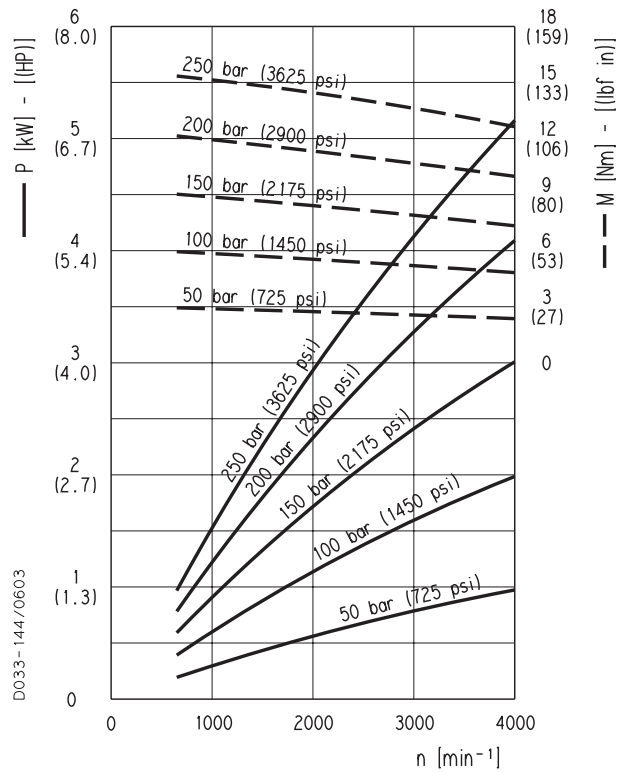

PLM 10•5

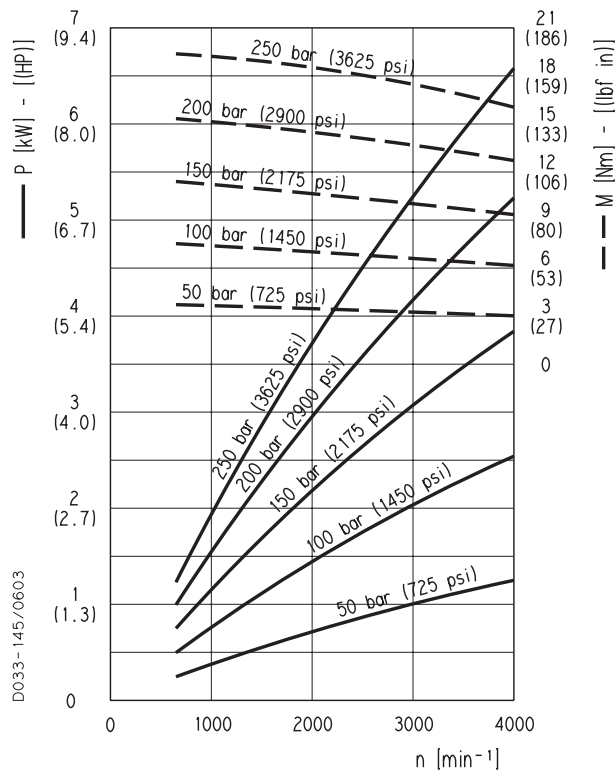

PLM 10•5,8

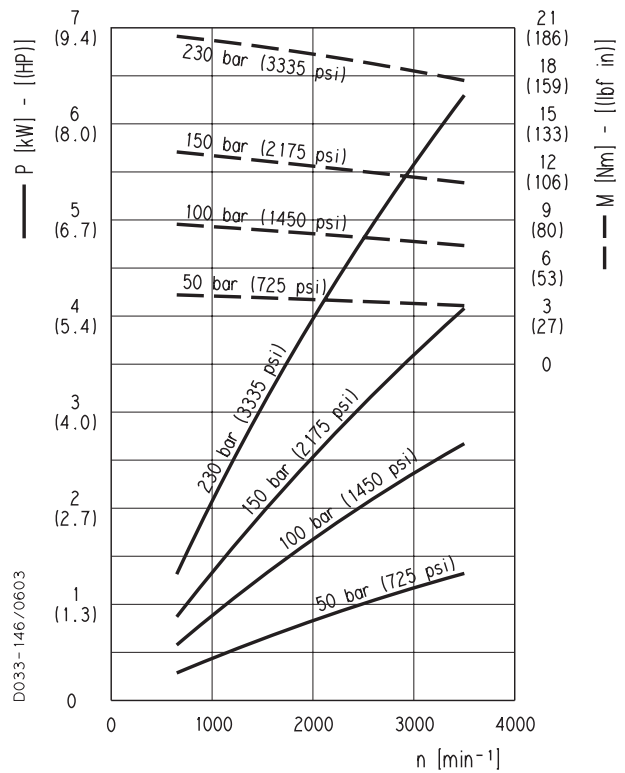

01/10.03

D033-145/0603

D033-146/0603

POLARIS 10 GEAR MOTORS PERFORMANCE CURVES

PLM 10

PLM 10•6,3

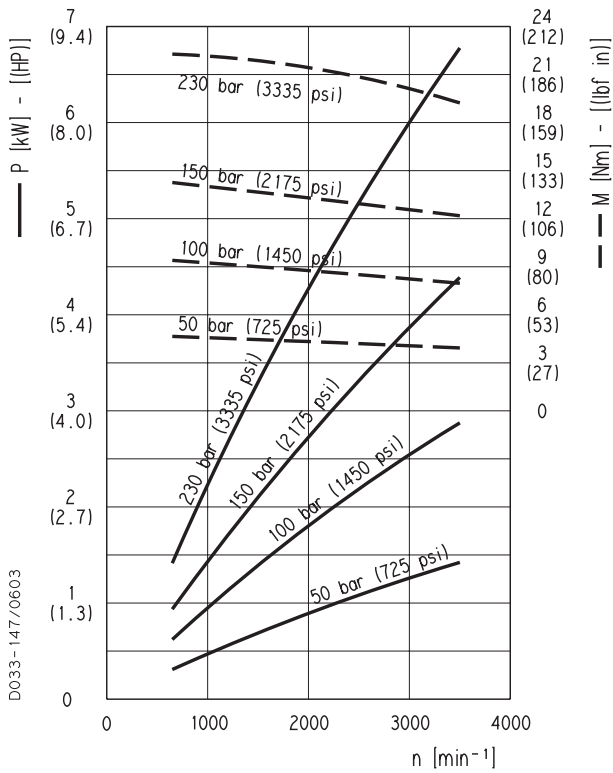

PLM 10•8

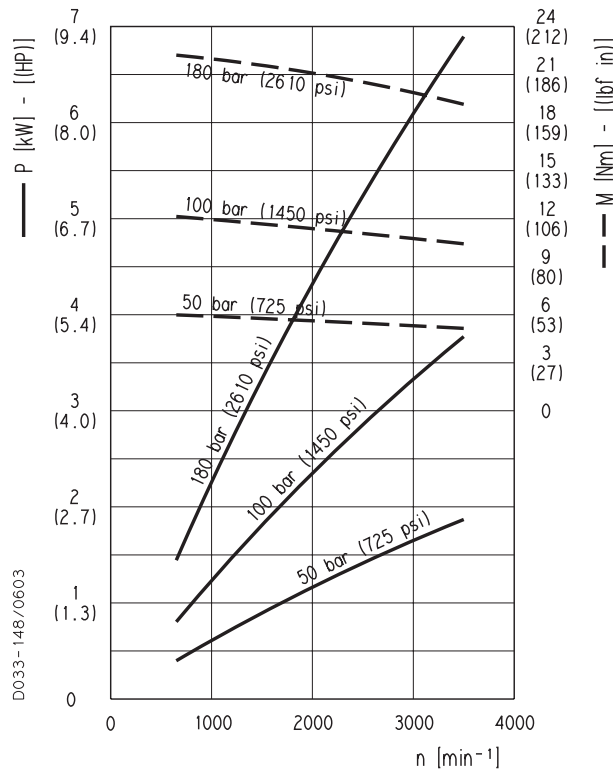

PLM 10•10

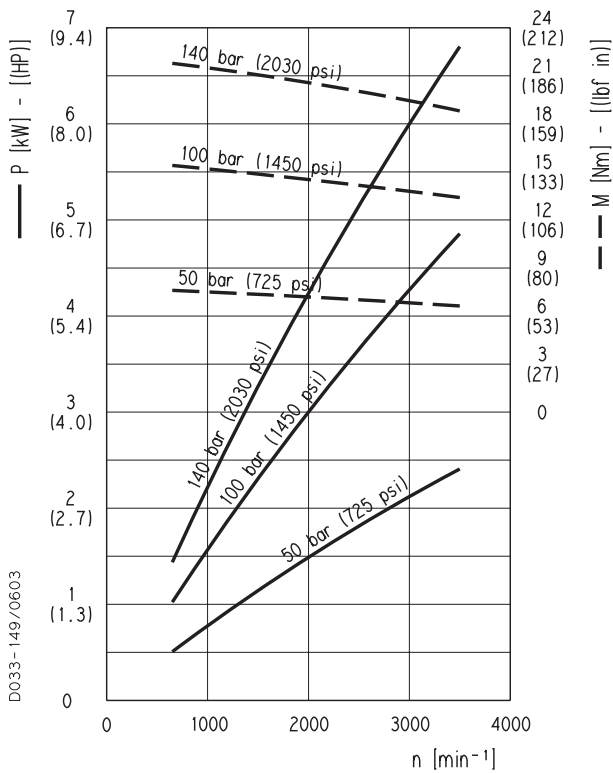

01/10.03

POLARIS 20 GEAR MOTORS PERFORMANCE CURVES

PLM 20

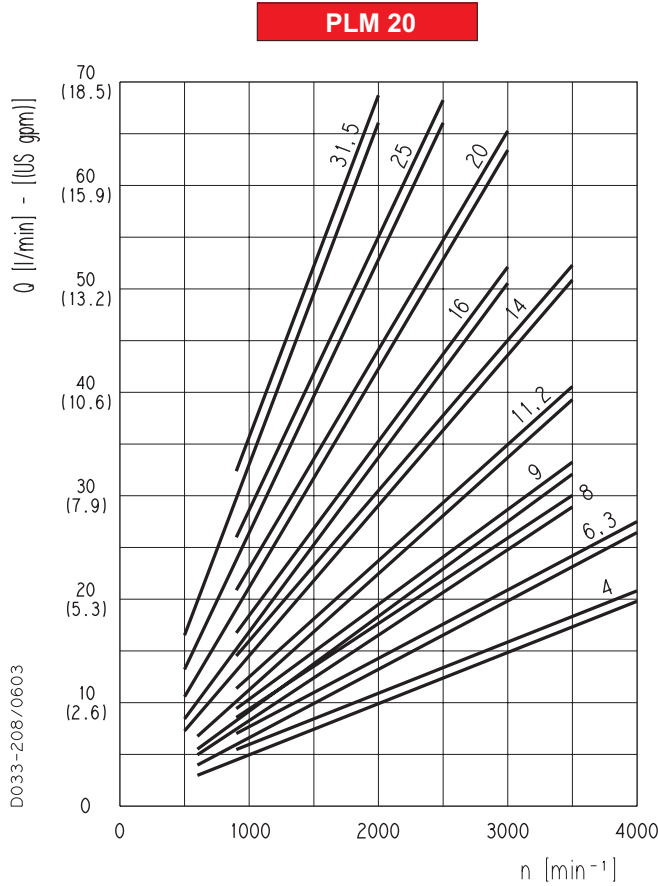

Each curve has been obtained at 122 °F (50°C), using oil with viscosity 168 SSU (36 cSt) at 104 °F (40°C) and at these pressures.

- PLM 20•4 290-3625 psi (20-250 bar)
- PLM 20•6,3 . . . 290-3625 psi (20-250 bar)
- PLM 20•8 290-3625 psi (20-250 bar)
- PLM 20•9 290-3625 psi (20-250 bar)
- PLM 20•11,2 . . . 290-3625 psi (20-250 bar)
- PLM 20•14 . . . 290-3625 psi (20-250 bar)
- PLM 20•16 . . . 290-3625 psi (20-250 bar)
- PLM 20•20 . . . 290-2900 psi (20-200 bar)
- PLM 20•25 . . . 290-2465 psi (20-170 bar)
- PLM 20•31,5 . . 290-1885 psi (20-130 bar)

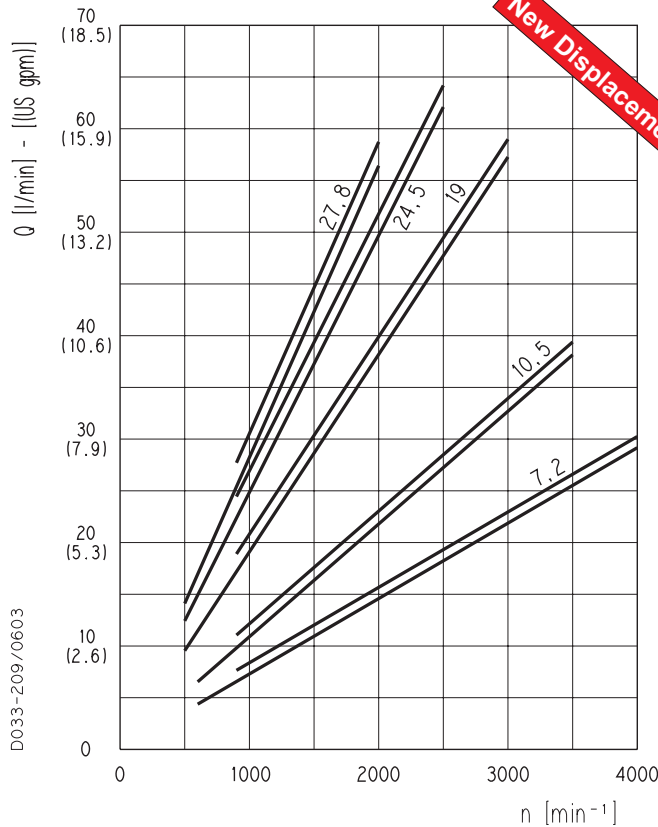

- PLM 20•7,2 . . . 290-3625 psi (20-250 bar)
- PLM 20•10,5 . . 290-3625 psi (20-250 bar)
- PLM 20•19 . . . 290-2900 psi (20-200 bar)
- PLM 20•24,5 . . 290-2465 psi (20-170 bar)
- PLM 20•27,8 . . 290-1885 psi (20-130 bar)

01/10.03

POLARIS 20 GEAR MOTORS PERFORMANCE CURVES

PLM 20

PLM 20•4

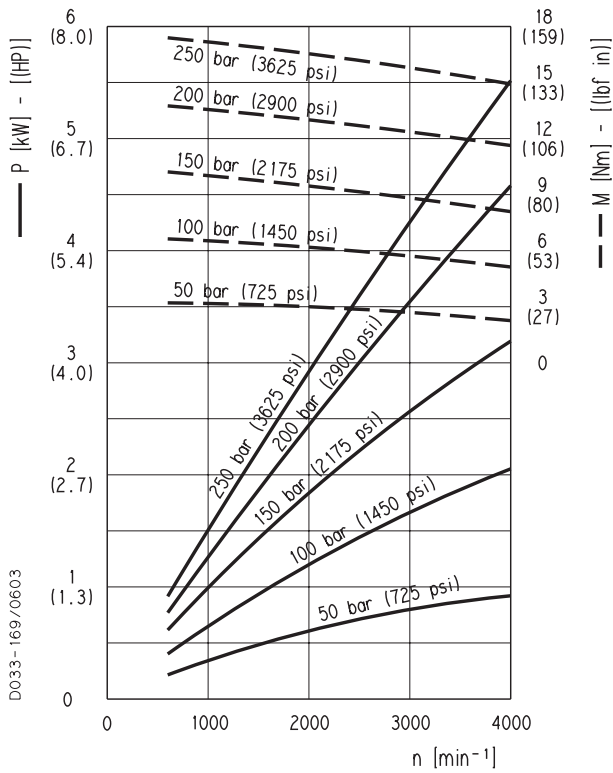

PLM 20•6,3

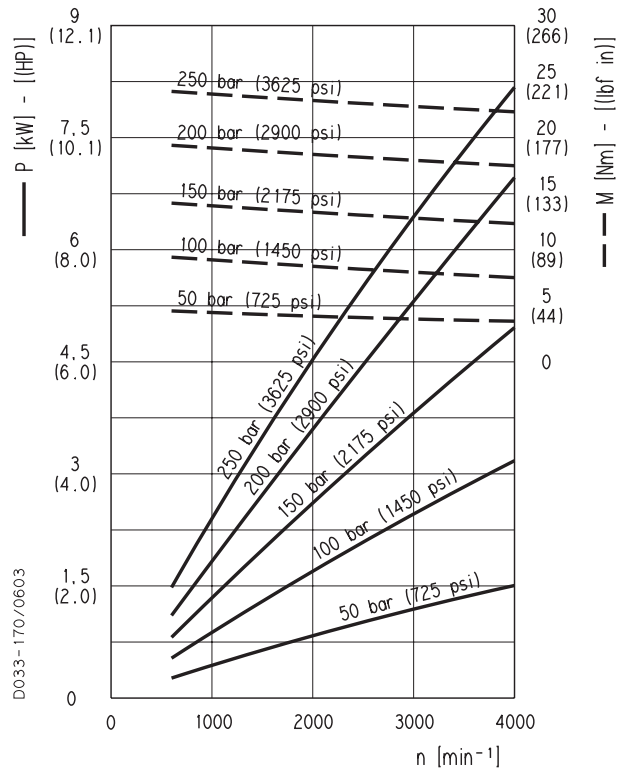

PLM 20•7,2

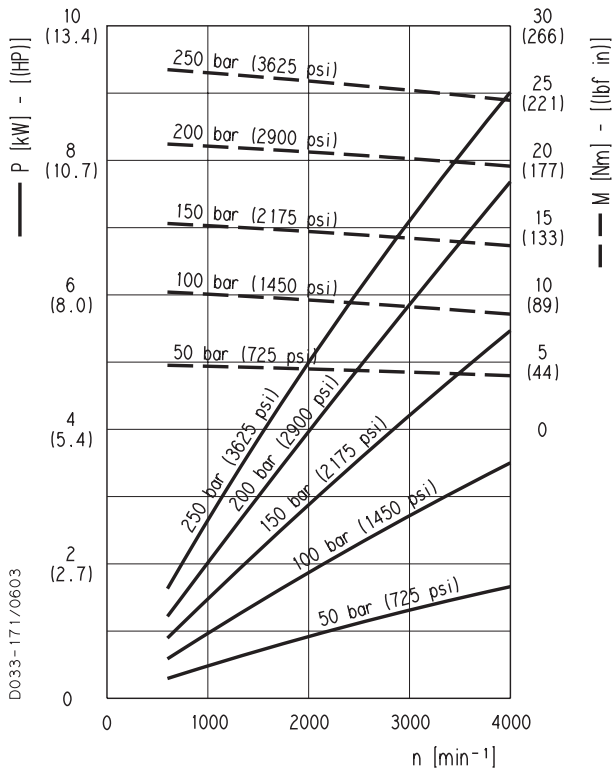

PLM 20•8

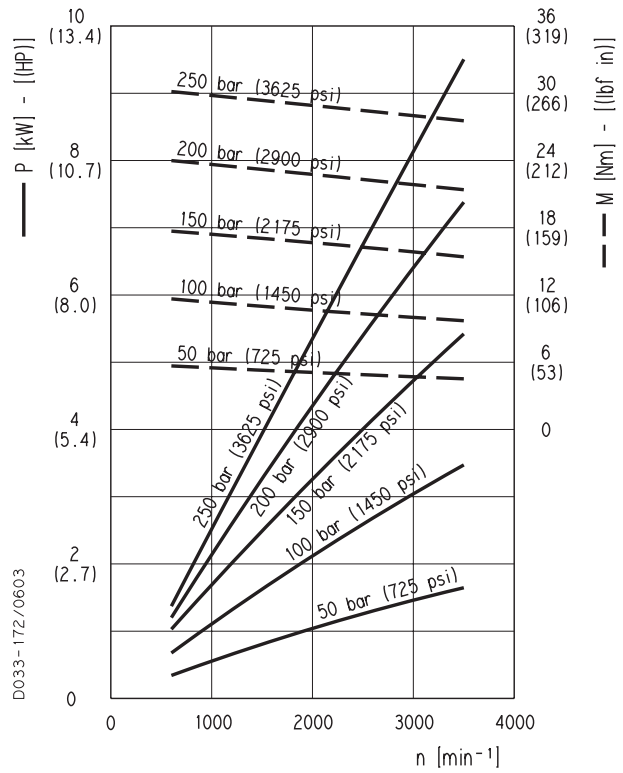

01/10.03

POLARIS 20 GEAR MOTORS PERFORMANCE CURVES

PLM 20

PLM 20-9

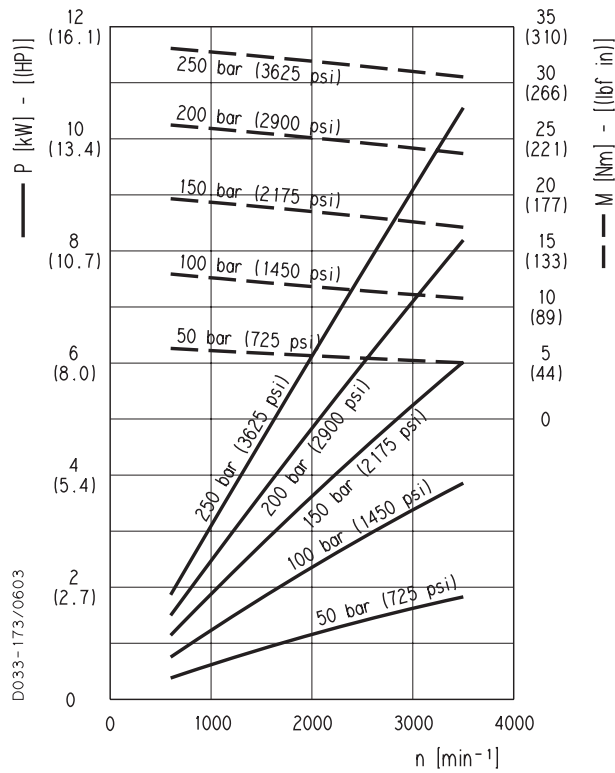

PLM 20-10,5

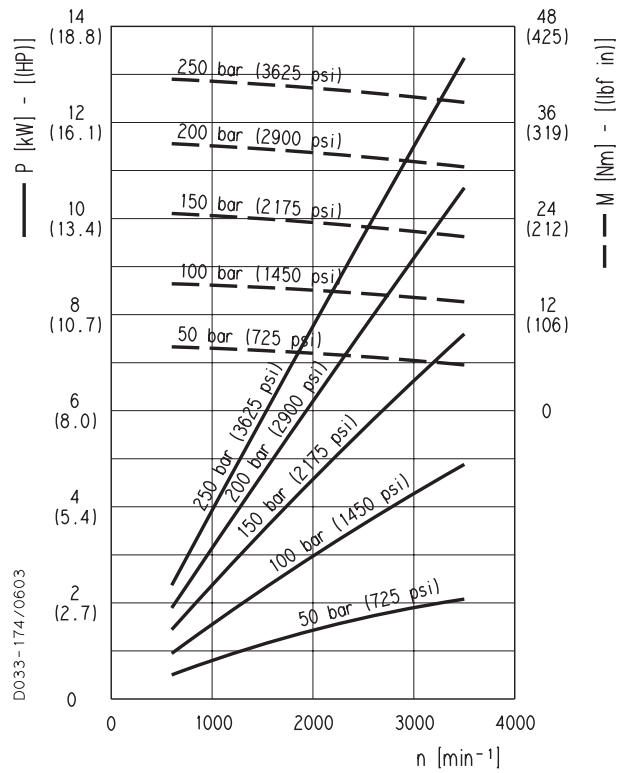

PLM 20-11,2

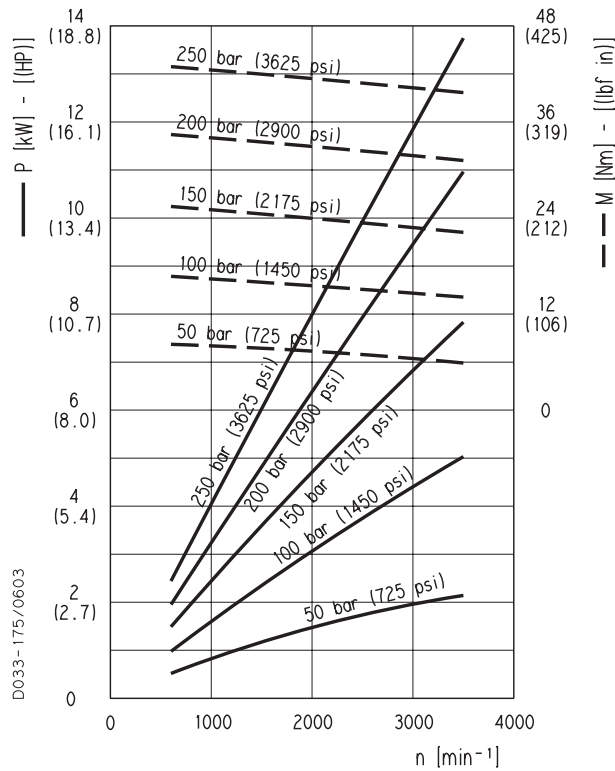

PLM 20-14

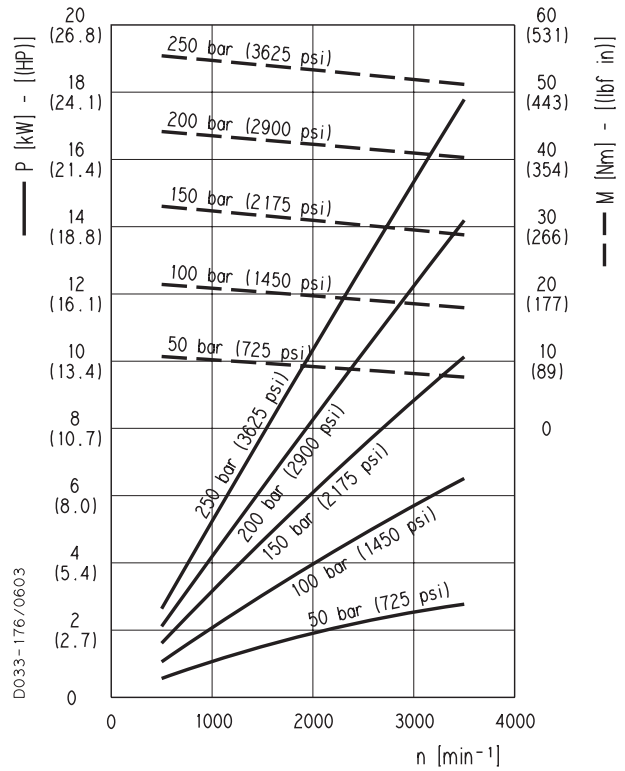

01/10.03

D033-175/0603

D033-176/0603

POLARIS 20 GEAR MOTORS PERFORMANCE CURVES

PLM 20

PLM 20-16

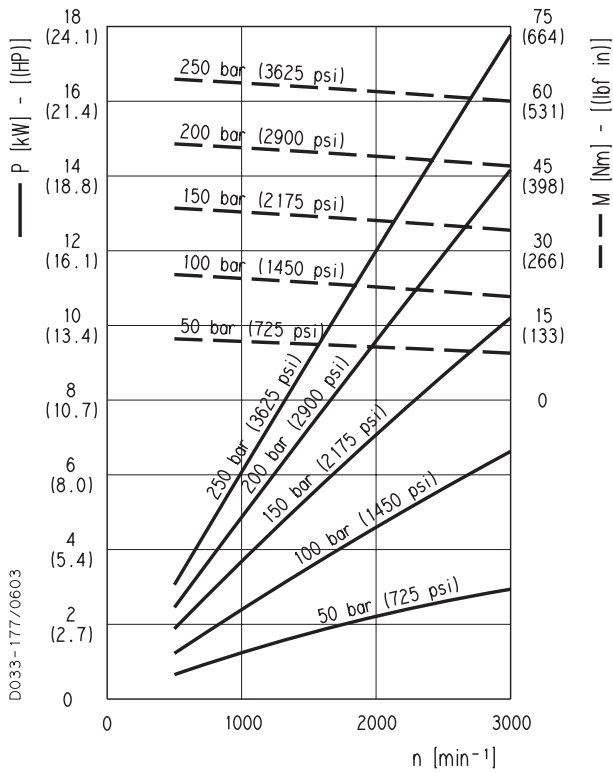

PLM 20-19

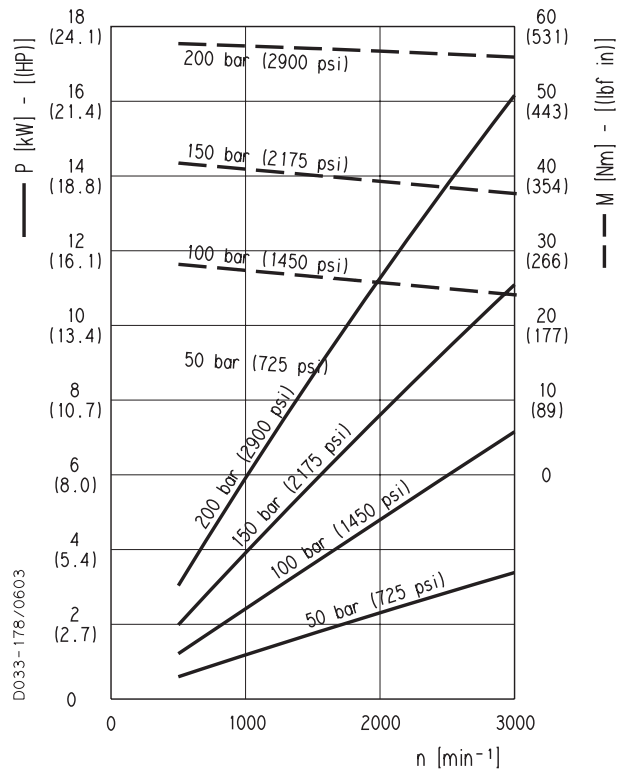

PLM 20-20

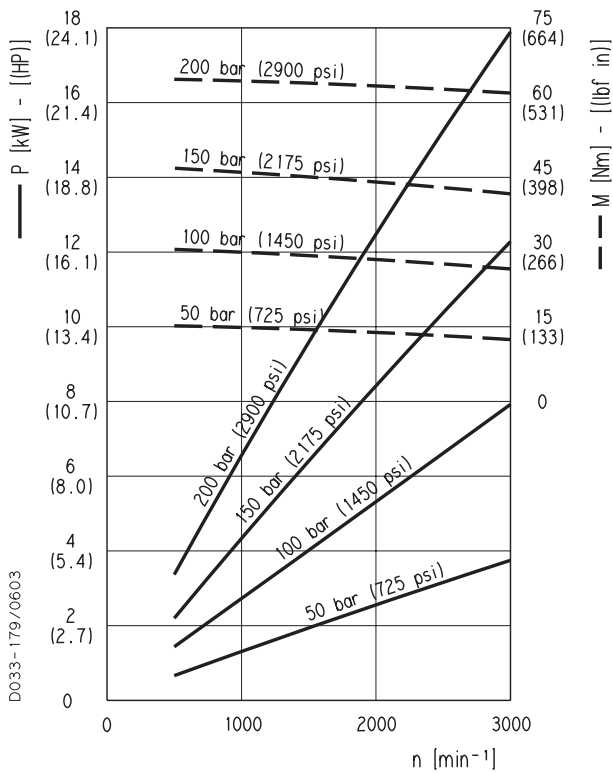

PLM 20-24,5

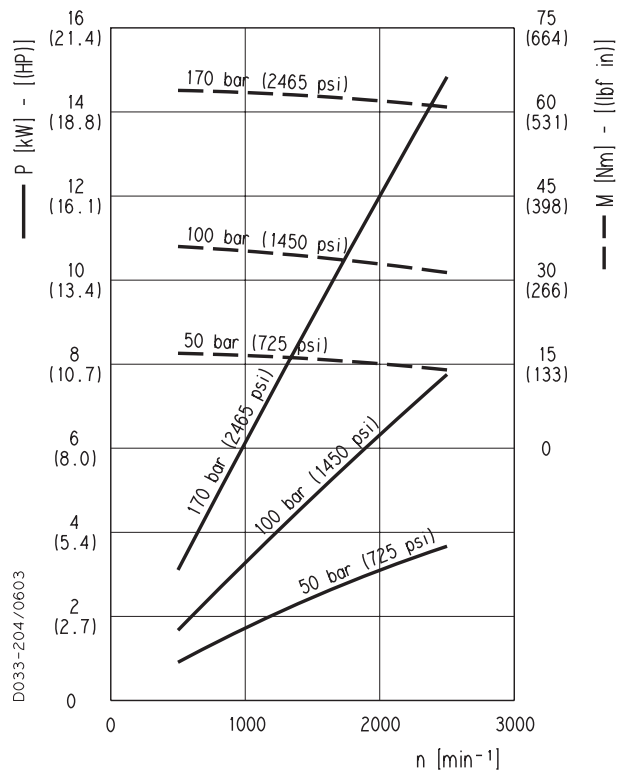

01/10.03

POLARIS 20 GEAR MOTORS PERFORMANCE CURVES

PLM 20

PLM 20•25

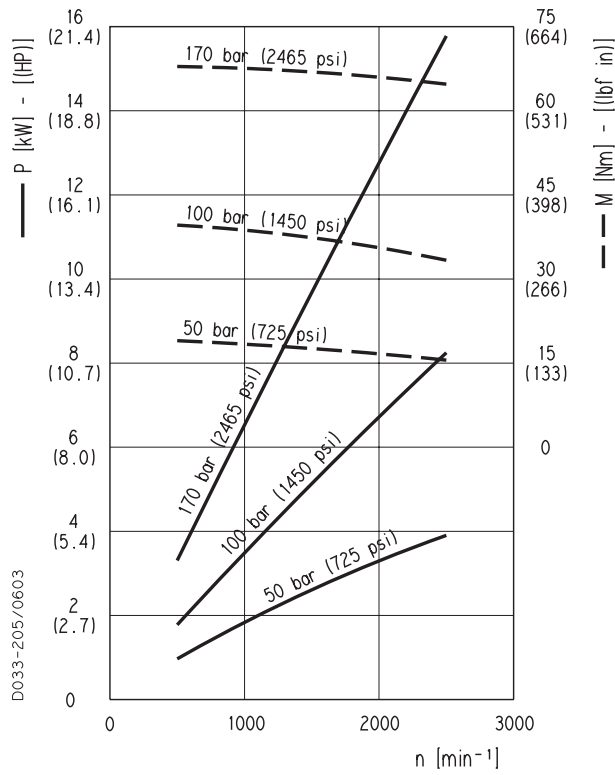

PLM 20•27,8

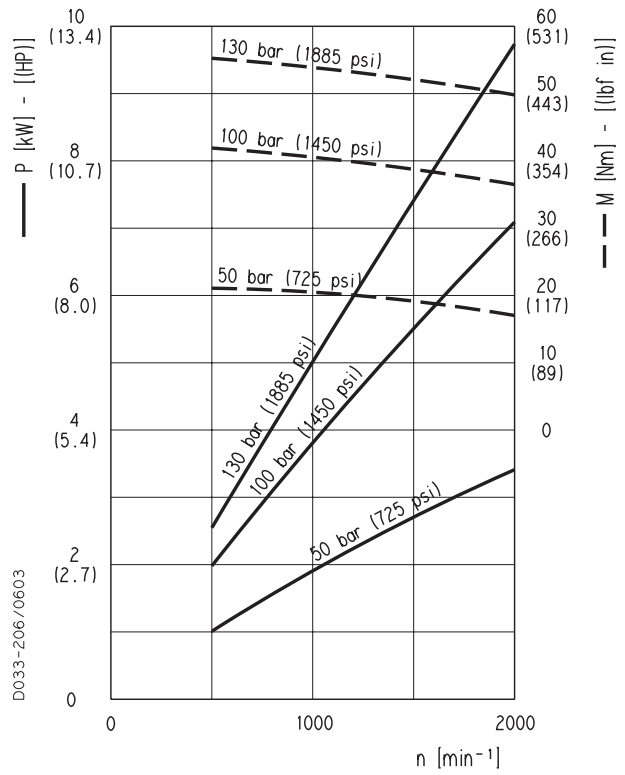

PLM 20•31,5

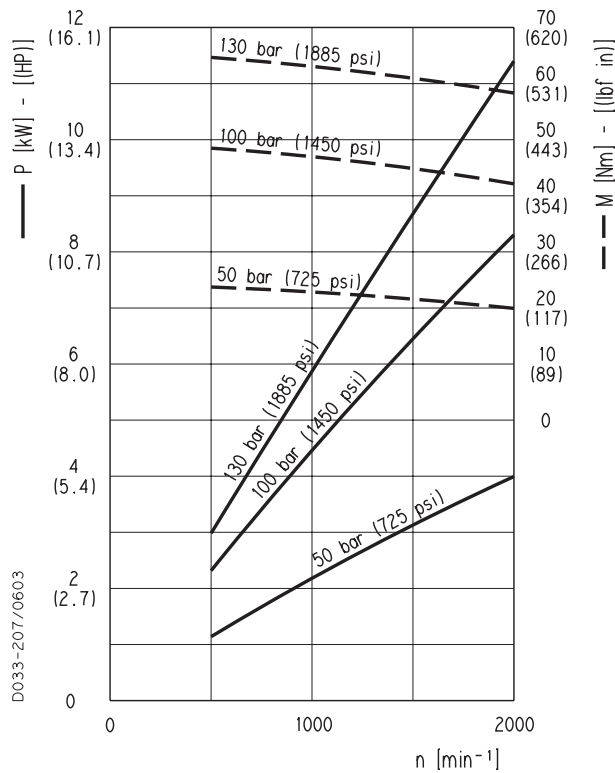

01/10.03

POLARIS 30 GEAR MOTORS PERFORMANCE CURVES

PLM 30

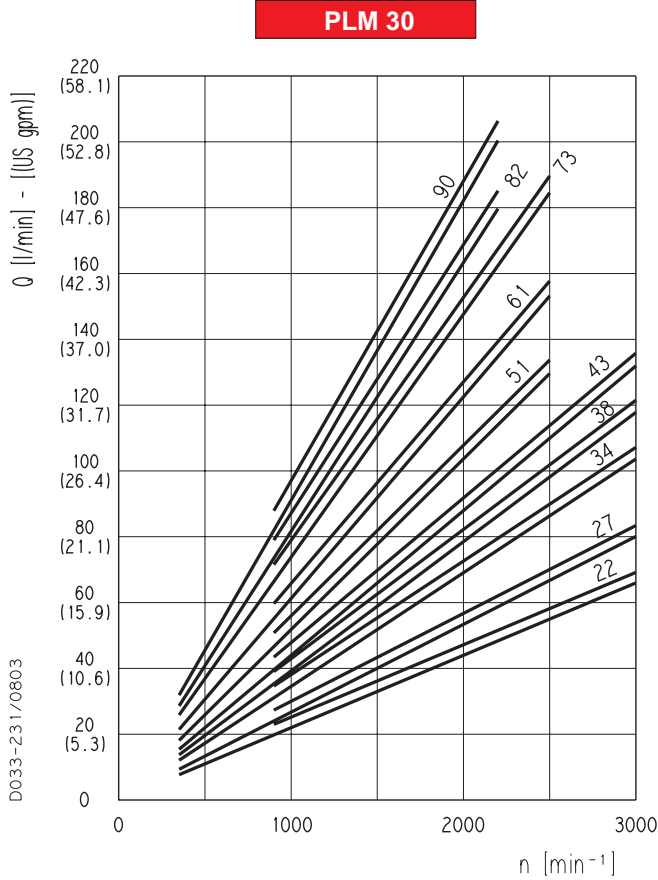

Each curve has been obtained at 122 °F (50°C), using oil with viscosity 168 SSU (36 cSt) at 104 °F (40°C) and at these pressures.

- PLM 30•22 . . . 290-3625 psi (20-250 bar)
- PLM 30•27 . . . 290-3625 psi (20-250 bar)
- PLM 30•34 . . . 290-3480 psi (20-240 bar)
- PLM 30•38 . . . 290-3480 psi (20-240 bar)
- PLM 30•43 . . . 290-3335 psi (20-230 bar)
- PLM 30•51 . . . 290-3045 psi (20-210 bar)
- PLM 30•61 . . . 290-2775 psi (20-190 bar)
- PLM 30•73 . . . 290-2465 psi (20-170 bar)
- PLM 30•82 . . . 290-2320 psi (20-160 bar)
- PLM 30•90 . . . 290-2175 psi (20-150 bar)

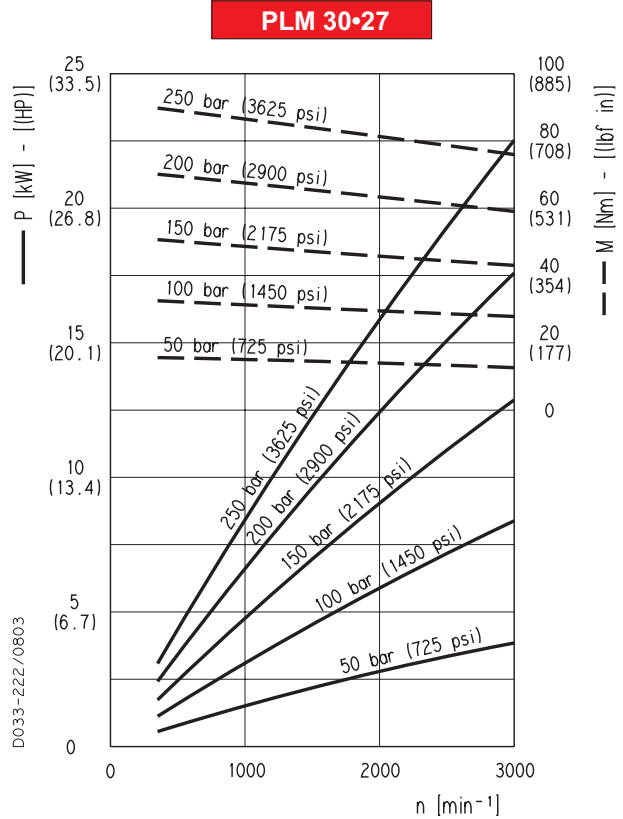
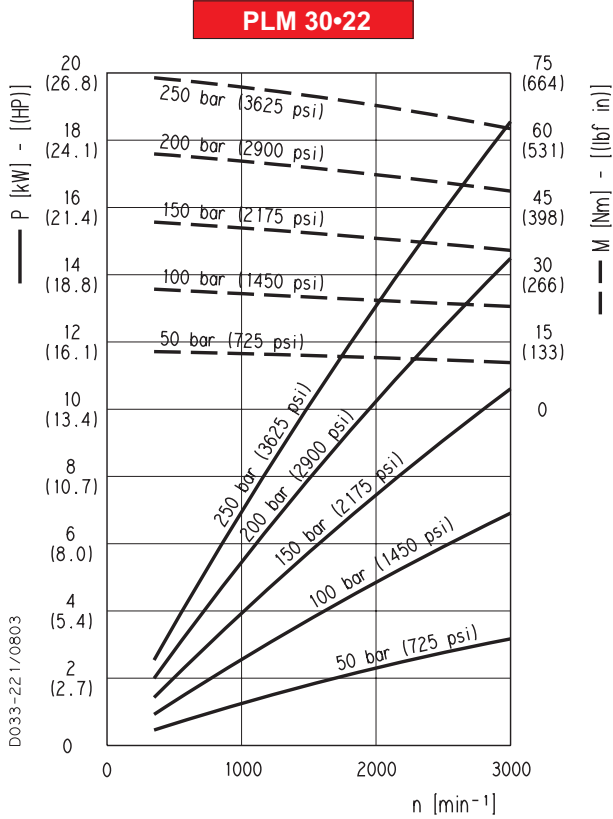

01/10.03

POLARIS 30 GEAR MOTORS PERFORMANCE CURVES

PLM 30

PLM 30-34

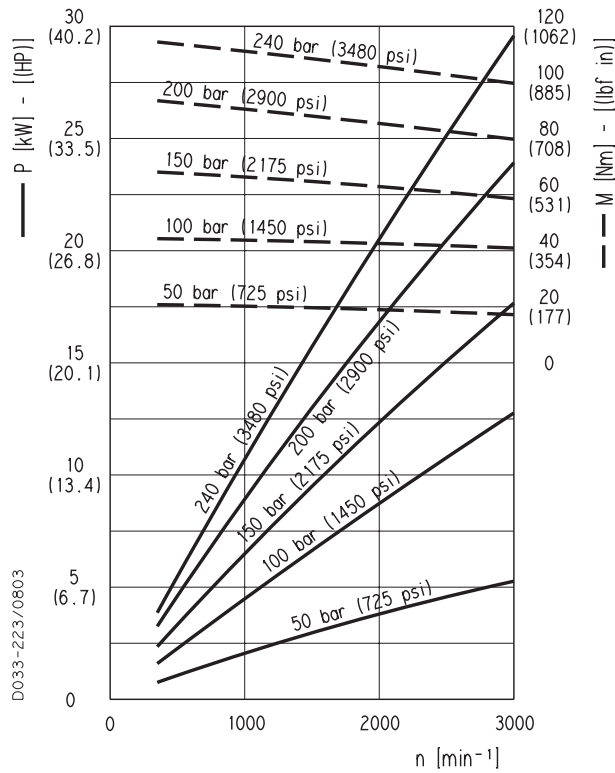

PLM 30-38

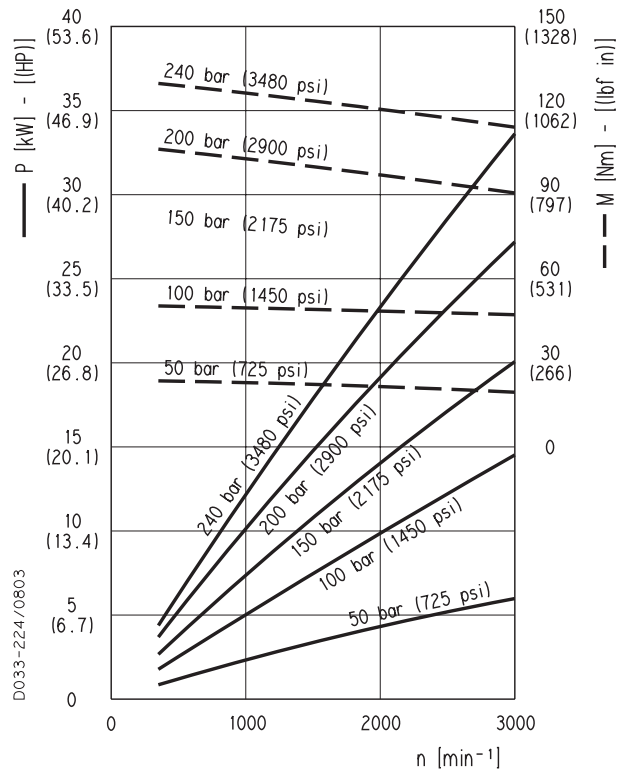

PLM 30-43

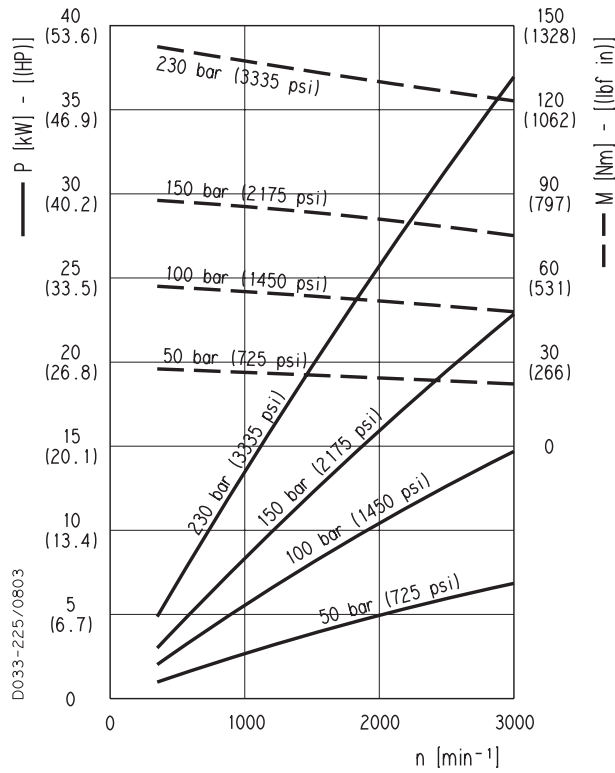

PLM 30-51

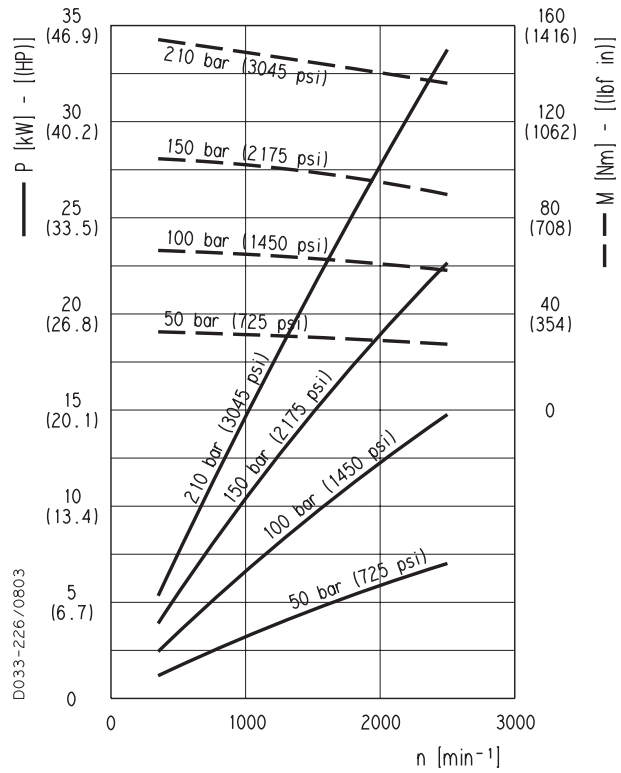

01/10.03

POLARIS 30 GEAR MOTORS PERFORMANCE CURVES

PLM 30

PLM 30-61

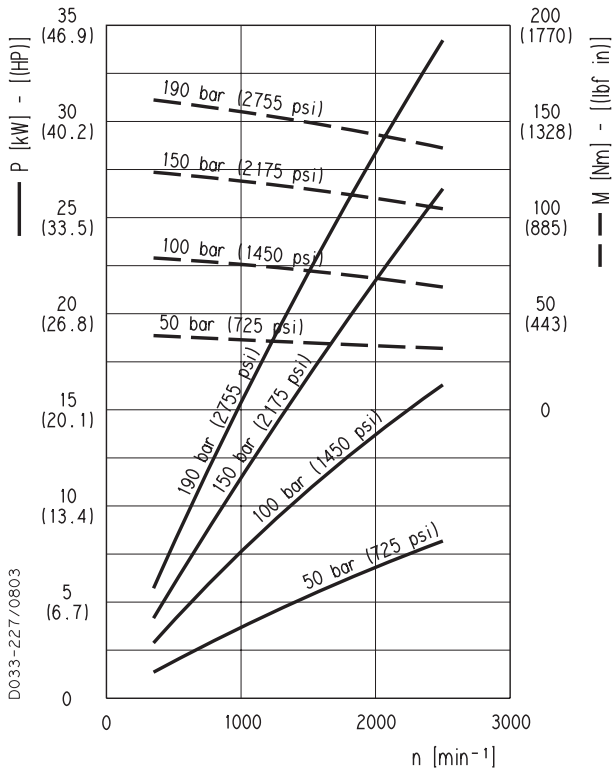

PLM 30-73

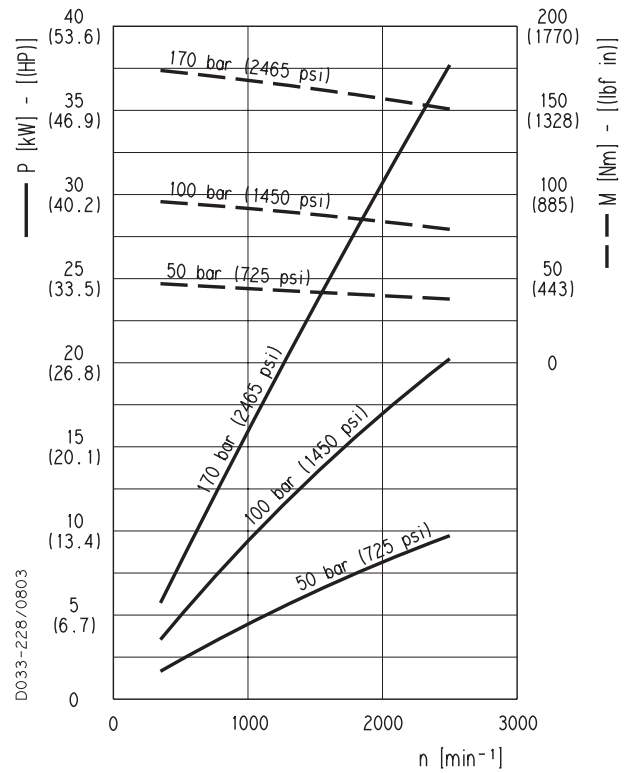

PLM 30-82

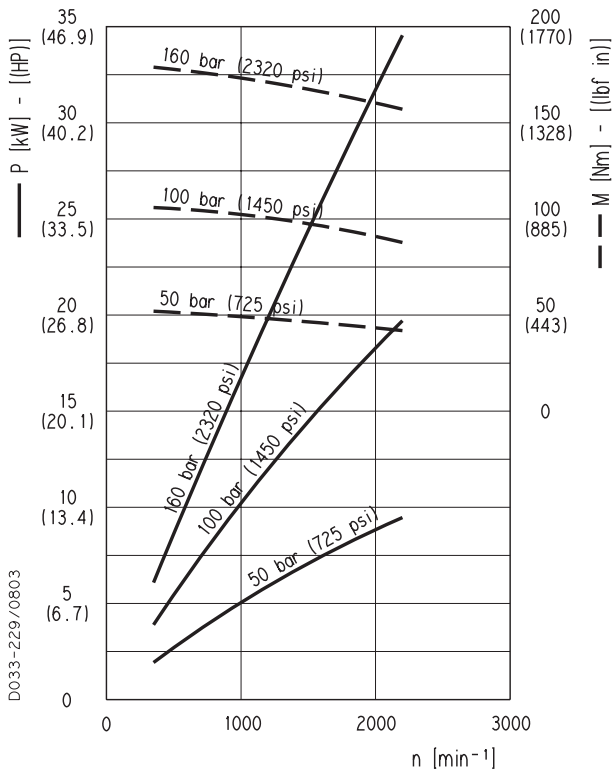

PLM 30-90

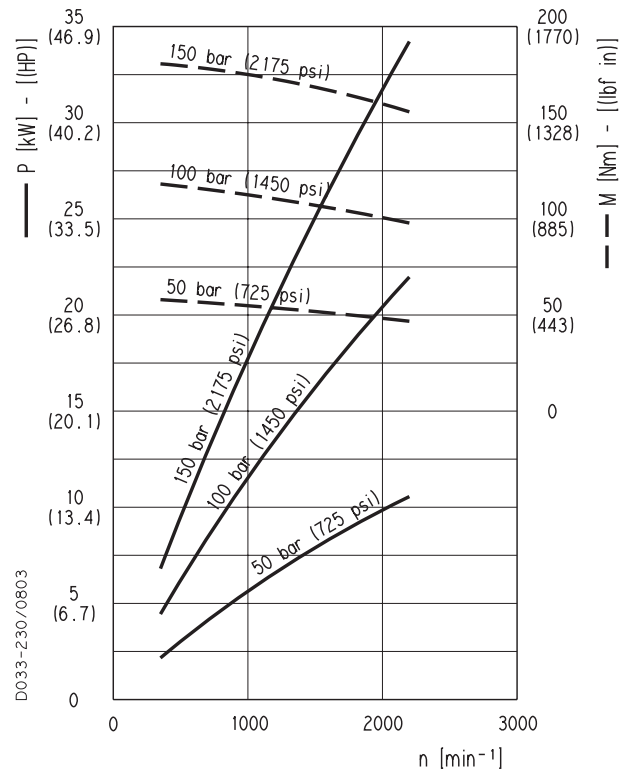

01/10.03

POLARIS 10

SINGLE UNITS SIDE PORTS

L

Replaces: 01/10.03

D033-180/0903

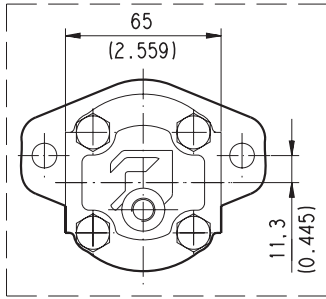

Reversible R

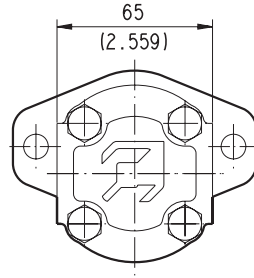

Single rotation S - D

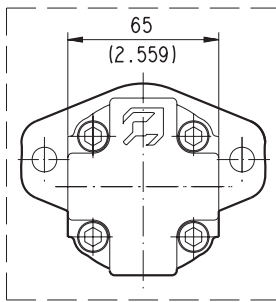

Reversible B

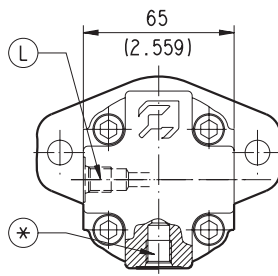

Reversible L

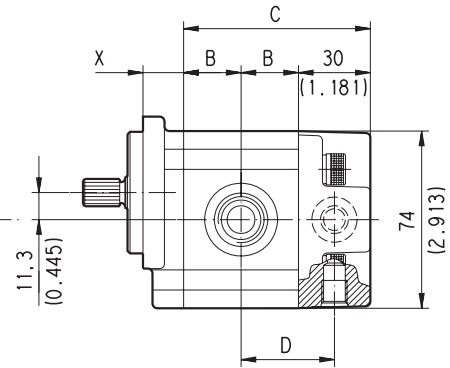
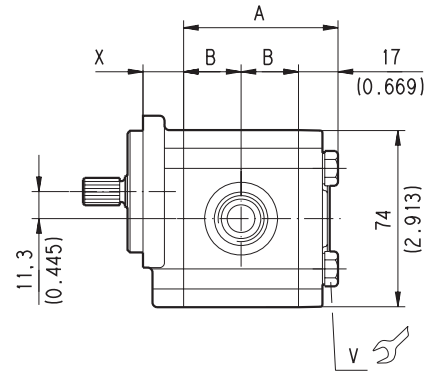

Mounting flange type version 0	X
	mm (inch)
E1	14 (0.5512)
E7	14 (0.5512)
E8	14 (0.5512)
B1	14 (0.5512)
K2	11,8 (0.4646)
S0	17 (0.6693)
R8	41 (1.6142)
R9	41 (1.6142)
W9	41 (1.6142)

○ For single rotation S - D and reversible rotation R the rear cover is available in cast iron and aluminium. For reversible rotation B and L the rear cover is available in aluminium only.

DRAIN PORT POSITION:

L = Side * = Bottom

DRIVE SHAFTS:

see page 51

MOUNTING FLANGE:

see page 57 ÷ 59

Mounting flange material	Screws tightening torque Nm (lbf in)
	V
Aluminium	25 ±2,5 (199 ÷ 243)
Cast iron	

Pump type Motor type	A	B	C	D
	mm (inch)	mm (inch)	mm (inch)	mm (inch)
PL. 10•1	52,2 (2.0551)	17,6 (0.6929)	65,2 (2.5669)	32,6 (1.2835)
PL. 10•1,5	53,8 (2.1181)	18,4 (0.7244)	66,8 (2.6299)	33,4 (1.3150)
PL. 10•2	55,4 (2.1811)	19,2 (0.7559)	68,4 (2.6929)	34,2 (1.3465)
PL. 10•2,5	57 (2.2441)	20 (0.7874)	70 (2.7559)	35 (1.3780)
PL. 10•3,15	59 (2.3228)	21 (0.8268)	72 (2.8346)	36 (1.4173)
PL. 10•4	61,8 (2.4331)	22,4 (0.8819)	74,8 (2.9449)	37,4 (1.4724)
PL. 10•5	65 (2.5591)	24 (0.9449)	78 (3.0709)	39 (1.5354)
PL. 10•5,8	67,6 (2.6614)	25,3 (0.9961)	80,6 (3.1732)	40,3 (1.5866)
PL. 10•6,3	69 (2.7165)	26 (1.0236)	82 (3.2283)	41 (1.6142)
PL. 10•8	74,5 (2.9331)	28,75 (1.1319)	87,5 (3.4449)	43,75 (1.7224)
PL. 10•10	81 (3.1890)	32 (1.2598)	94 (3.7008)	47 (1.8504)

○ 02/07.2006

POLARIS 10

SINGLE UNITS REAR PORTS

P

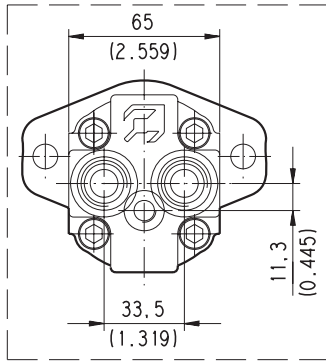

Reversible R

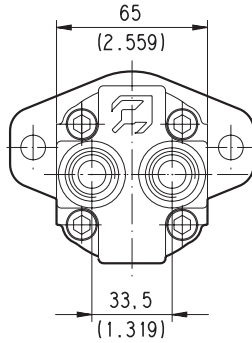

Single rotation S - D and Reversible B

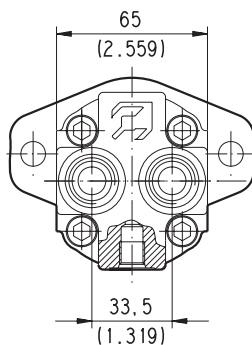
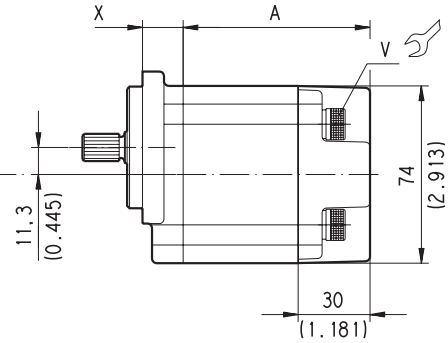

Reversible L

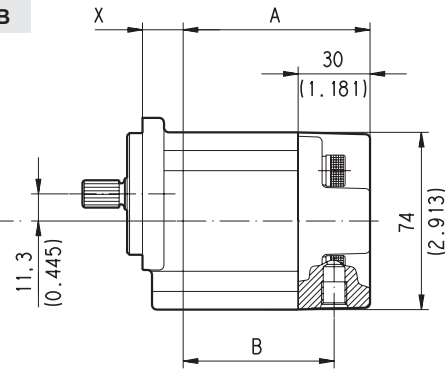

D033-181/0903

Mounting flange type version 0	X
	mm (inch)
E1	14 (0.5512)
E7	14 (0.5512)
E8	14 (0.5512)
B1	14 (0.5512)
K2	11,8 (0.4646)
S0	17 (0.6693)
R8	41 (1.6142)
R9	41 (1.6142)
W9	41 (1.6142)

○ The rear cover is available in aluminium only.

DRIVE SHAFTS:
see page 51
MOUNTING FLANGE:
see page 57 ÷ 59

Mounting flange material	Screws tightening torque Nm (lbf in)
	V
Aluminium	25 ±2,5 (199 ÷ 243)
Cast iron	

Pump type Motor type	A	B
	mm (inch)	mm (inch)
PL. 10•1	65,2 (2.5669)	50,2 (1.9764)
PL. 10•1,5	66,8 (2.6299)	51,8 (2.0394)
PL. 10•2	68,4 (2.6929)	53,4 (2.0124)
PL. 10•2,5	70 (2.7559)	55 (2.1654)
PL. 10•3,15	72 (2.8346)	57 (2.2441)
PL. 10•4	74,8 (2.9449)	59,8 (2.3543)
PL. 10•5	78 (3.0709)	63 (2.4803)
PL. 10•5,8	80,6 (3.1732)	65,6 (2.5827)
PL. 10•6,3	82 (3.2283)	67 (2.6378)
PL. 10•8	87,5 (3.4449)	72,5 (2.8543)
PL. 10•10	94 (3.7008)	79 (3.1102)

Replaces: 01/10.03

○ 02/07.2006

POLARIS 20

SINGLE UNITS SIDE PORTS

L

Replaces: 01/10.03

D033-182/0903

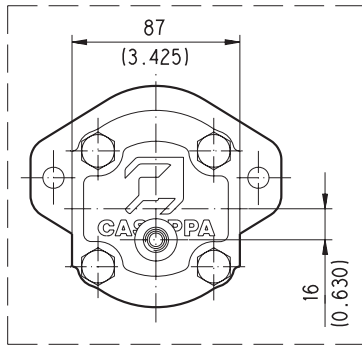

Reversible R

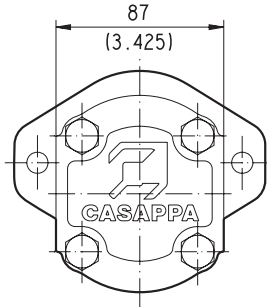

Single rotation S - D and Reversible B

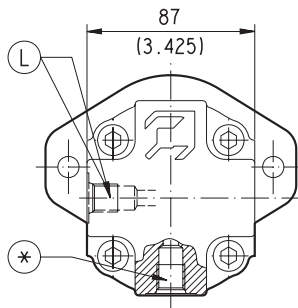
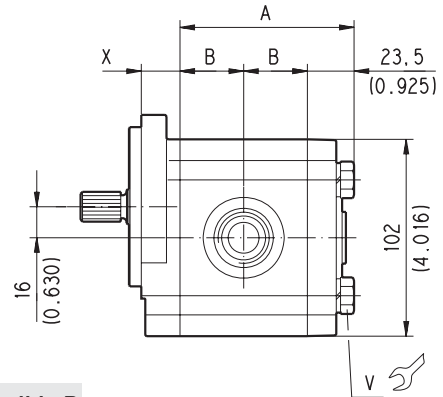

Reversible L

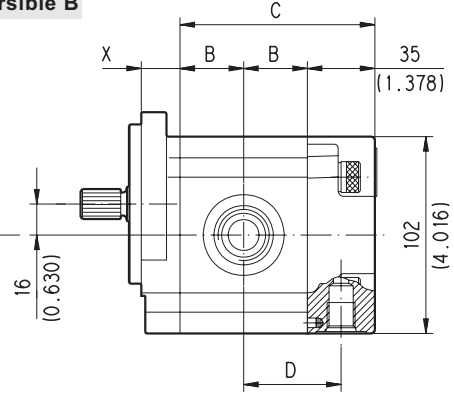

Mounting flange type version 0	X	
	mm (inch)	
E2	18	(0.7087)
B2	18,8	(0.7402)
B4	16	(0.6299)
B5	16	(0.6299)
B6	17,7	(0.6969)
S1	20	(0.7874)
S2	20	(0.7874)
S9	20	(0.7874)
S5	20	(0.7874)
W8	32,1	(1.2638)

For single rotation S - D, reversible rotation R and B the rear cover is available in cast iron and aluminium. For reversible rotation L the rear cover is available in aluminium only.

DRAIN PORT POSITION:

L = Side * = Bottom

DRIVE SHAFTS:

see page 52 ÷ 54

MOUNTING FLANGE:

see page 60 ÷ 64

Mounting flange material	Screws tightening torque
	Nm (lbf in)
Aluminium	45 ^{+4,5} (358 ÷ 438)
Cast iron	70 ⁺⁷ (558 ÷ 682)

02/07.2006

Pump type Motor type	A	B	C	D
	mm (inch)	mm (inch)	mm (inch)	mm (inch)
PL. 20•4	75 (2.9528)	25,75 (1.0138)	86,5 (3.4055)	43,25 (1.7028)
PL. 20•6,3	77,5 (3.0512)	27 (1.0630)	89 (3.5039)	44,5 (1.7520)
PL. 20•7,2	78,5 (3.0905)	27,5 (1.0826)	90 (3.5433)	45 (1.7716)
PL. 20•8	80 (3.1496)	28,25 (1.1122)	91,5 (3.6024)	45,75 (1.8012)
PL. 20•9	81,3 (3.2008)	28,9 (1.1378)	92,8 (3.6535)	46,4 (1.8268)
PL. 20•10,5	84 (3.3070)	30,25 (1.1909)	95,5 (3.7598)	47,75 (1.8799)
PL. 20•11,2	84,5 (3.3268)	30,5 (1.2008)	96 (3.7795)	48 (1.8898)
PL. 20•14	89,5 (3.5236)	33 (1.2992)	101 (3.9764)	50,5 (1.9882)
PL. 20•16	93 (3.6614)	34,75 (1.3681)	104,5 (4.1142)	52,25 (2.0571)
PL. 20•19	96,4 (3.7952)	36,45 (1.4350)	107,9 (4.2480)	53,45 (2.1043)
PL. 20•20	99,5 (3.9173)	38 (1.4961)	111 (4.3701)	55,5 (2.1850)
PL. 20•24,5	105,1 (4.1378)	40,8 (1.6063)	116,6 (4.5905)	58,3 (2.2953)
PL. 20•25	107,5 (4.2323)	42 (1.6535)	119 (4.6850)	59,5 (2.3425)
PL. 20•27,8	110,2 (4.3386)	43,35 (1.7067)	121,7 (4.7913)	60,85 (2.3957)
PL. 20•31,5	117,5 (4.6260)	47 (1.8504)	129 (5.0787)	64,5 (2.5394)

POLARIS 20

SINGLE UNITS REAR PORTS

P

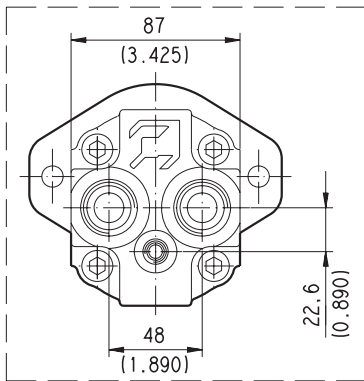

Reversible R

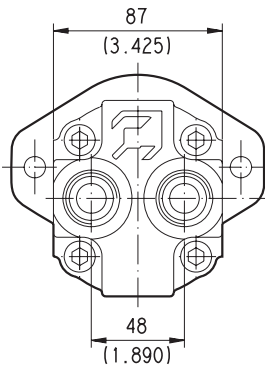

Single rotation S - D e Reversible B

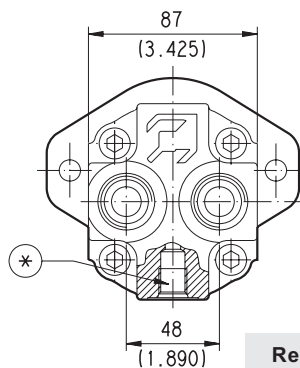
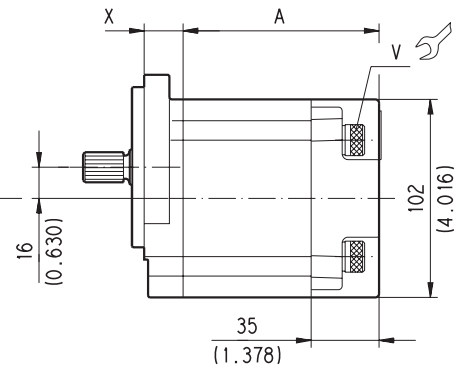

Reversible L

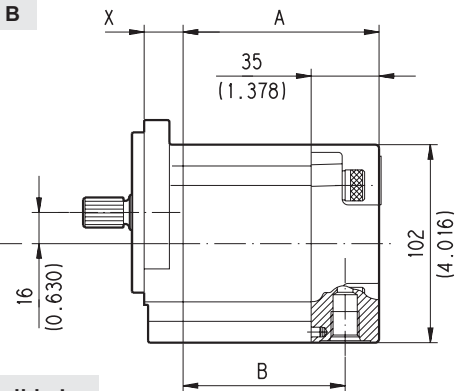

D033-183/0903

Mounting flange type version 0	X	
	mm	(inch)
E2	18	(0.7087)
B2	18,8	(0.7402)
B4	16	(0.6299)
B5	16	(0.6299)
B6	17,7	(0.6969)
S1	20	(0.7874)
S2	20	(0.7874)
S9	20	(0.7874)
S5	20	(0.7874)
W8	32,1	(1.2638)

○ The rear cover is available in aluminium only.

DRAIN PORT POSITION:

L = Side * = Bottom

DRIVE SHAFTS:

see page 52 ÷ 54

MOUNTING FLANGE:

see page 60 ÷ 64

Mounting flange material	Screws tightening torque Nm (lbf in)
	V
Aluminium	45 ^{+4,5} (358 ÷ 438)
Cast iron	70 ⁺⁷ (558 ÷ 682)

Pump type Motor type	A	B
	mm (inch)	mm (inch)
PL. 20•4	86,5 (3.4055)	69 (2.71765)
PL. 20•6,3	89 (3.5039)	71,5 (2.8150)
PL. 20•7,2	90 (3.5433)	72,5 (2.8543)
PL. 20•8	91,5 (3.6024)	74 (2.9134)
PL. 20•9	92,8 (3.6535)	75,3 (2.9646)
PL. 20•10,5	95,5 (3.7598)	78 (3.0708)
PL. 20•11,2	96 (3.7795)	78,5 (3.0906)
PL. 20•14	101 (3.9764)	83,5 (3.2784)
PL. 20•16	104,5 (4.1142)	87 (3.4252)
PL. 20•19	107,9 (4.2480)	89,9 (3.5393)
PL. 20•20	111 (4.3701)	93,5 (3.6811)
PL. 20•24,5	116,6 (4.5905)	99,1 (3.9016)
PL. 20•25	119 (4.6850)	101,5 (3.9961)
PL. 20•27,8	121,7 (4.7913)	104,2 (4.1024)
PL. 20•31,5	129 (5.0787)	111,5 (4.3898)

Replaces: 01/10.03

○ 02/07.2006

POLARIS 30

SINGLE UNITS SIDE PORTS

L

Replaces: 01/10.03

D033-184/0903

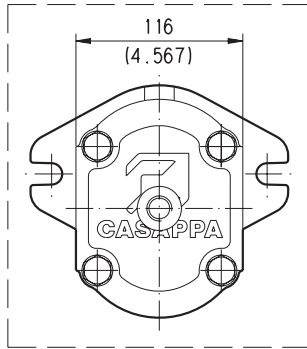

Reversible R

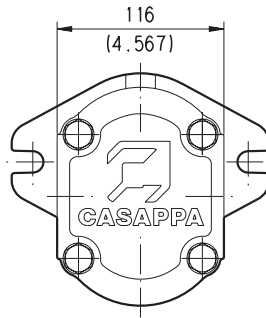

Single rotation S - D

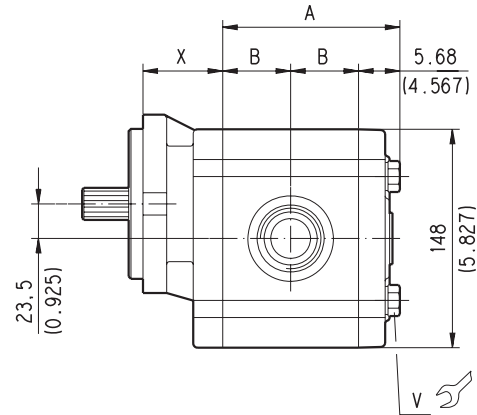

Mounting flange type version 0	X
	mm (inch)
E3	24 (0.945)
E4	25 (0.984)
B3	28 (1.102)
S5	54 (2.1260)
U3	20,8 (0.819)

○ The rear cover is available in cast iron only.

DRIVE SHAFTS:
see page 55 and page 56
MOUNTING FLANGE:
see page 65 ÷ 67

Mounting flange material	Screws tightening torque Nm (lbf in)
	V
Cast iron	100 ±10 (797 ÷ 974)

Pump type Motor type	A	B
	mm (inch)	mm (inch)
PL. 30•22	106 (4.1732)	39 (1.5354)
PL. 30•27	109 (4.2913)	40,5 (1.5945)
PL. 30•34	114 (4.4882)	43 (1.6929)
PL. 30•38	117 (4.6063)	44,5 (1.7520)
PL. 30•43	120 (4.7244)	46 (1.8110)
PL. 30•51	125 (4.9212)	48,5 (1.9094)
PL. 30•61	131 (5.1575)	51,5 (2.0276)
PL. 30•73	139 (5.4724)	55,5 (2.1850)
PL. 30•82	144 (5.6693)	58 (2.2835)
PL. 30•90	150 (5.9055)	61 (2.4016)

○ 02/07.2006

MULTIPLE PUMPS

POLARIS series pumps can be coupled together in combination. Where the input power requirements of each section varies, that with the greater requirement must be at the drive shaft end, and progressively smaller to the rear.

Features and performances are the same as the corresponding single pumps, but pressures must be limited by the transmissible torque of the drive and connecting shafts. To have appropriate data, use the formula below.

The maximum rotational speed is that of the lowest rated speed of the single units incorporated.

Available with common inlet and separated stages. For more information please consult our technical sales department.

M	lbf in (Nm)	Torque
V	in ³ /rev (cm ³ /rev)	Displacement
Δp	psi (bar)	Pressure
η _m = η _m (V, Δp, n) (≈ 0,88)		Mechanical efficiency

$$M = \frac{\Delta p \text{ (bar)} \cdot V \text{ (cm}^3\text{/rev)}}{62,83 \cdot \eta_m} \quad \text{[Nm]}$$

DRIVE SHAFT SELECTION

The torque absorbed from the shaft of the first pump results from the sum of the torques due to all single stages. The achieved value must not exceed the maximum torque limit given for the shaft of the first pump. Diagrams providing approximate selection data will be found on page 37.

Example

Let us consider a double pump PLP20•14 + PLP20•4. If we suppose that we have to work with the first pump at a pressure of 2900 psi (200 bar) and the second pump at a pressure of 2175 psi (150 bar), the graph 2 shows that the torque absorbed by PLP20•14 is 469 lbf in (53 Nm) and the PLP20•4 absorbs 115 lbf in (13 Nm) (acceptable value because it doesn't exceed the maximum drive shaft torque that is 973 lbf in (110 Nm), see page 39). The torque to be transmitted by the first drive shaft will thus be 469+115= 584 lbf in (53+13= 66 Nm), this value must not exceed the shaft's maximum rated value.

01/10.03

ABSORBED TORQUE

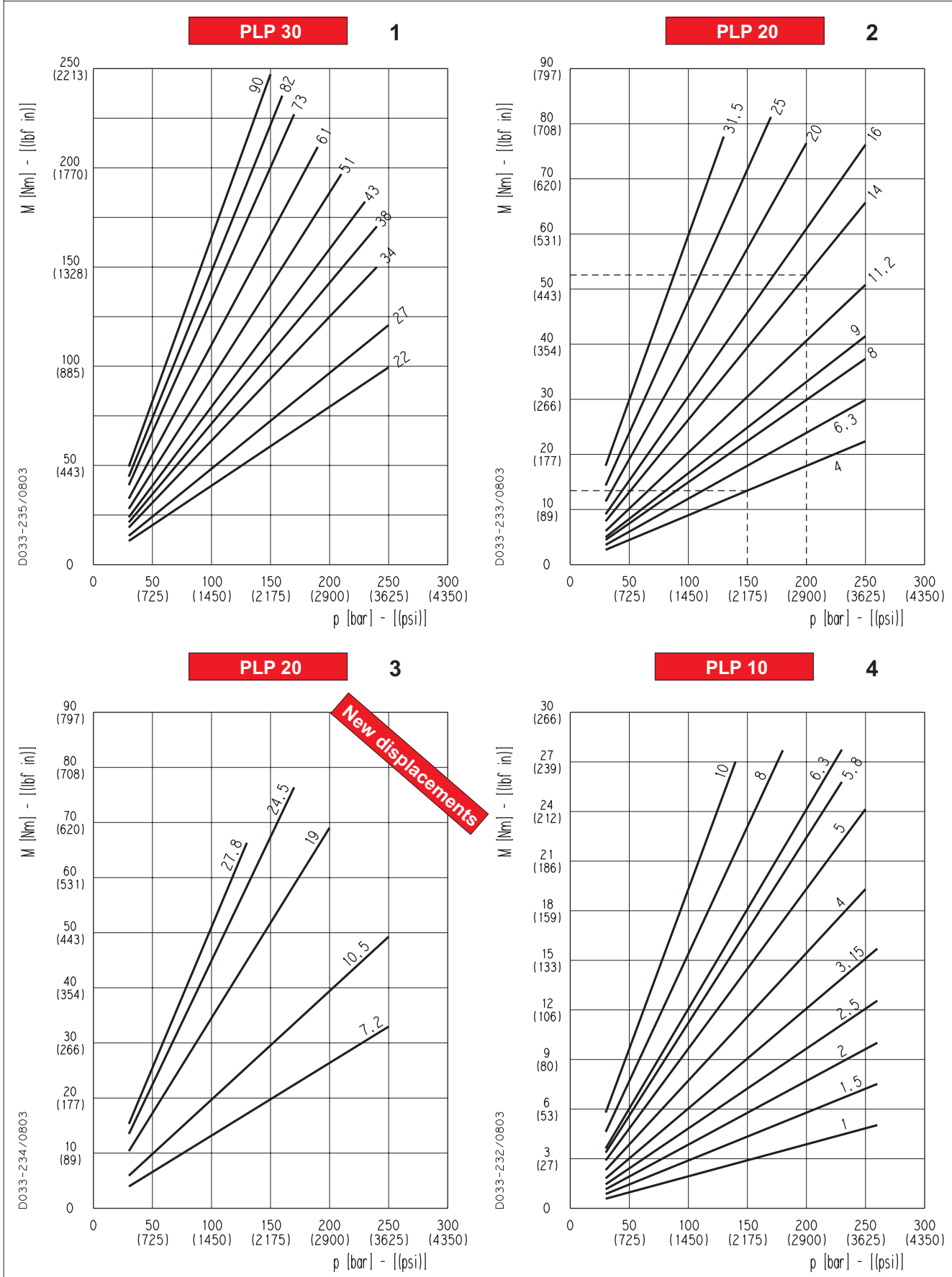

COMMON INLET - PORTS POSITION

PLP

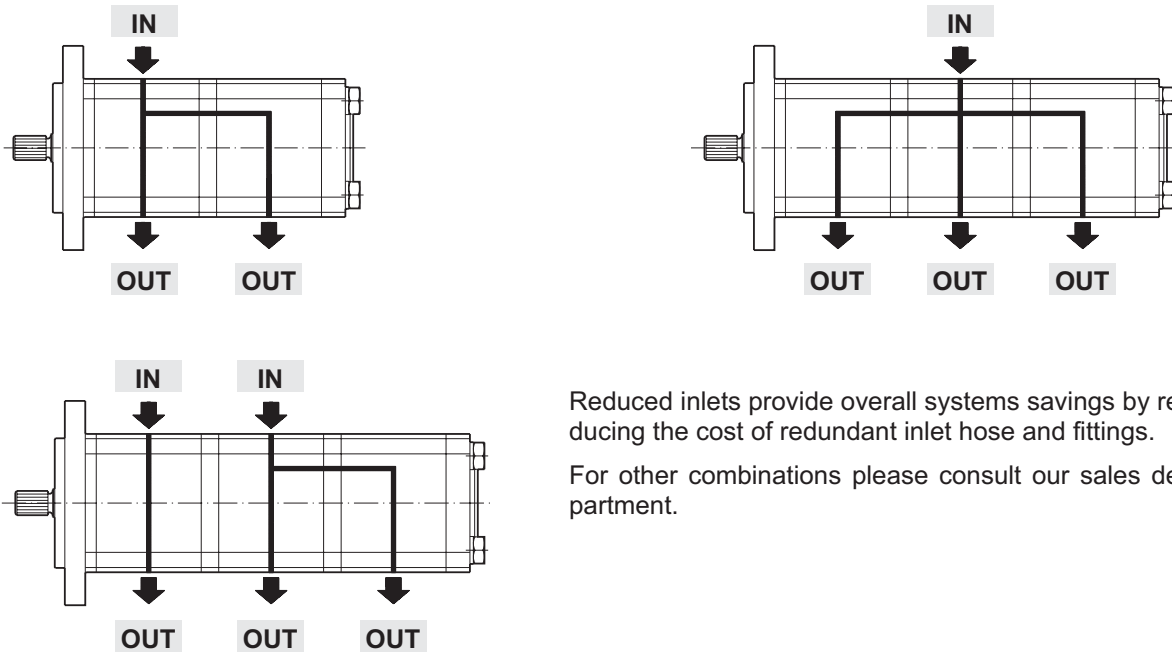

Reduced inlets provide overall systems savings by reducing the cost of redundant inlet hose and fittings.
For other combinations please consult our sales department.

Replaces: 01/10.03

MULTIPLE PUMPS COMBINATION

PLP 10

Polaris 10/10	STANDARD VERSION	V6
Polaris 10/10	COMMON INLET VERSION	V7

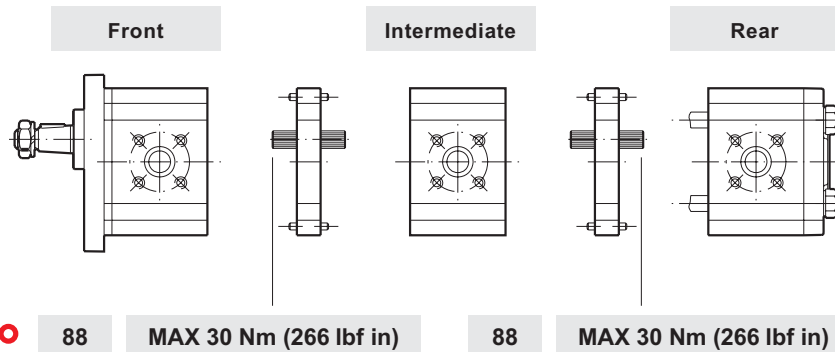

D033-112/0603

02/07.2006

MULTIPLE PUMPS COMBINATION

PLP 20

Polaris 20/20	STANDARD VERSION	S6
Polaris 20/20	COMMON INLET VERSION	S7

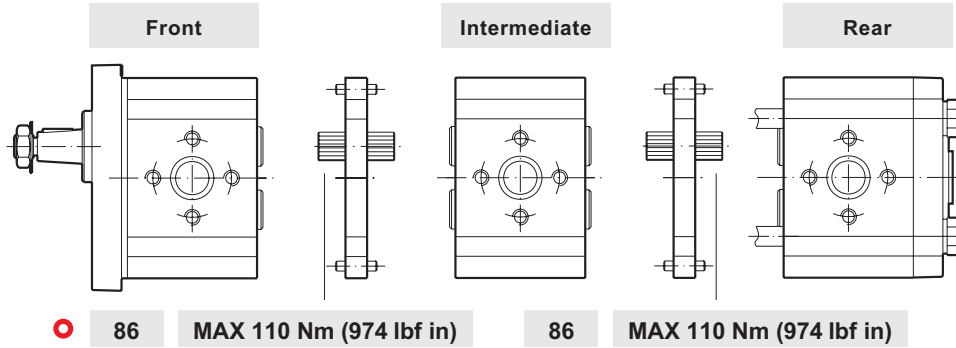

D033-106/0603

Polaris 20/20	SEPARATED STAGES VERSION	Z6
----------------------	---------------------------------	-----------

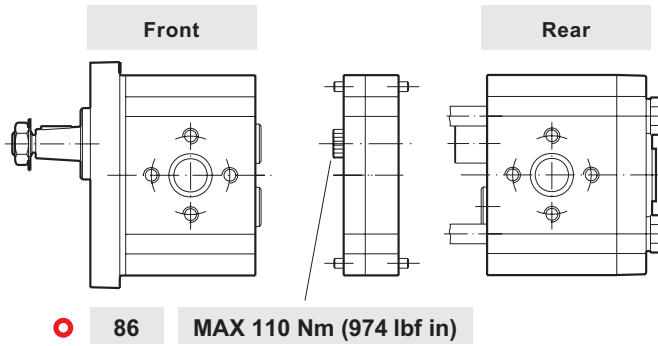

D033-110/0603

Polaris 20/10	STANDARD VERSION	T6
Polaris 20/10	COMMON INLET VERSION	T7

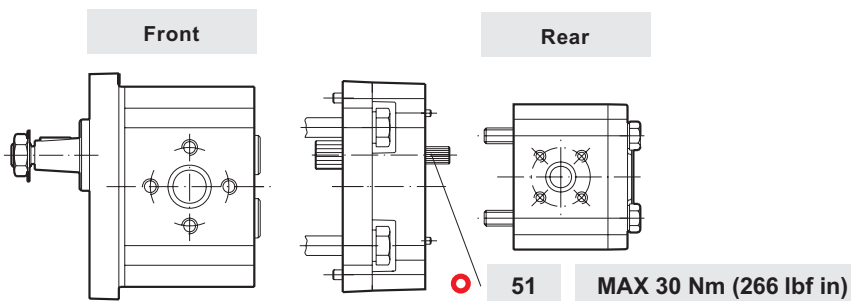

D033-107/0603

Polaris 20/10	SEPARATED STAGES VERSION	Z6
----------------------	---------------------------------	-----------

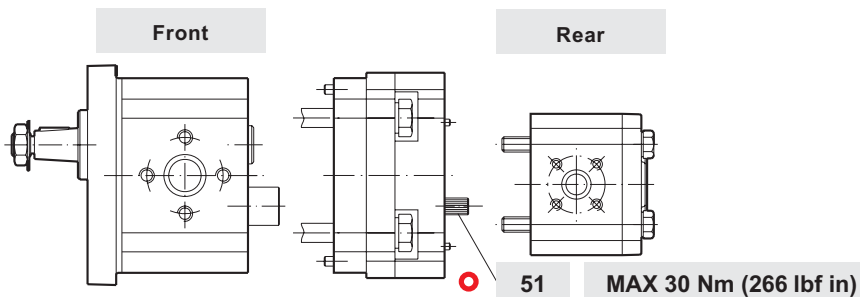

D033-111/0603

Replaces: 01/10.03

○ 02/07.2006

MULTIPLE PUMPS COMBINATION

PLP 30

Polaris 30/30

STANDARD VERSION

M6

Front

Intermediate

Rear

D033-100/0603

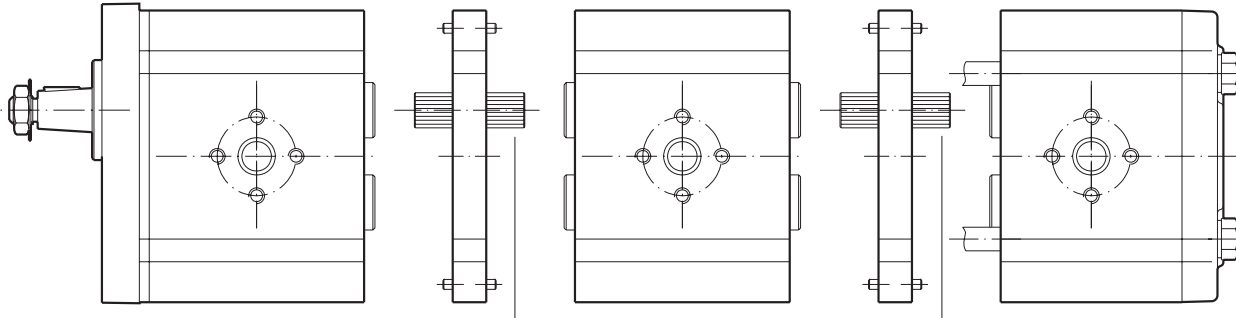

65

MAX 180 Nm (1593 lbf in)

65

MAX 180 Nm (1593 lbf in)

Polaris 30/20

STANDARD VERSION

N6

Polaris 30/20

COMMON INLET VERSION

N7

Front

Rear

D033-101/0603

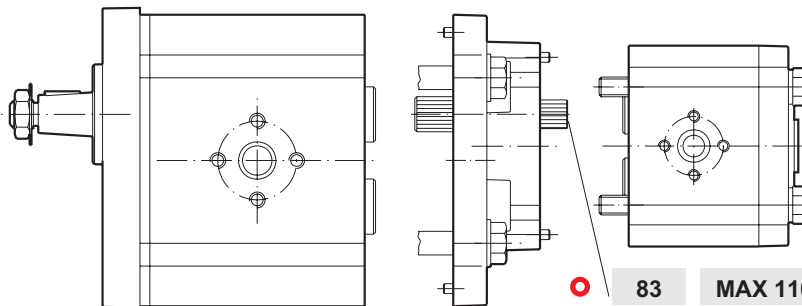

83

MAX 110 Nm (974 lbf in)

Polaris 30/20

SEPARATED STAGES VERSION

Z6

Front

Rear

D033-105/0603

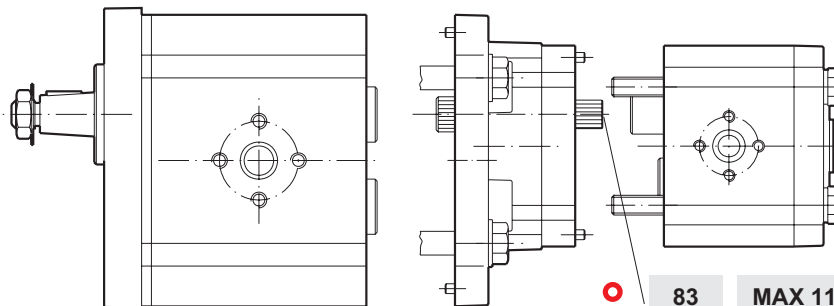

83

MAX 110 Nm (974 lbf in)

Replaces: 01/10.03

02/07.2006

Polaris 30/10	STANDARD VERSION	Q6
Polaris 30/10	COMMON INLET VERSION	Q7

Replaces: 01/10.03

D033-104/0603

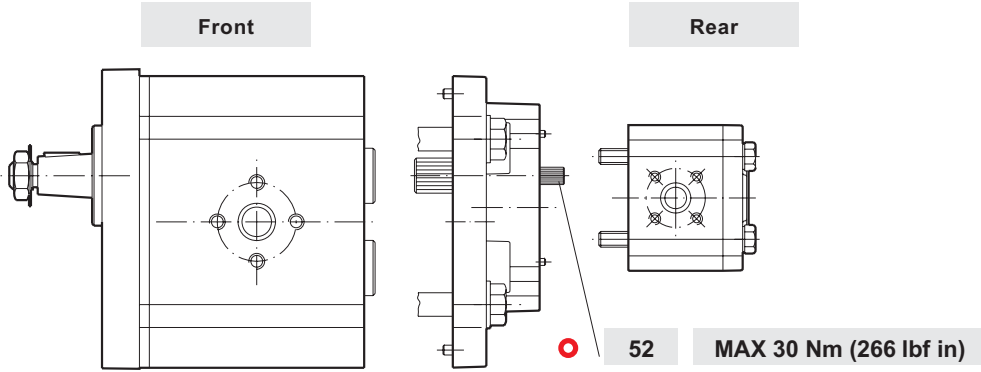

02/07.2006

D033-190/0903

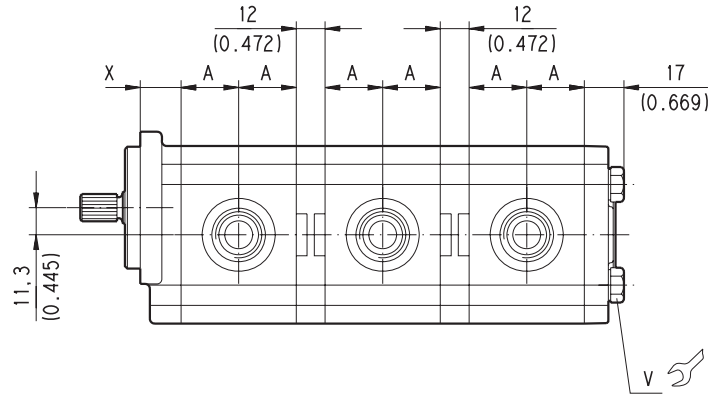
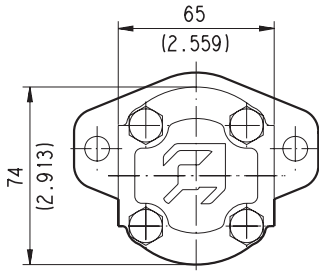

● The rear cover is available in cast iron and aluminium.

DRIVE SHAFTS: see page 51
MOUNTING FLANGE: see page 57 ÷ 59

Mounting flange material	● Screws tightening torque Nm (lbf in)
	V
Aluminium	25 ±2,5 (199 ÷ 243)
Cast iron	

Pump type	A
	mm (inch)
PLP 10•1	17,6 (0.6929)
PLP 10•1,5	18,4 (0.7244)
PLP 10•2	19,2 (0.7559)
PLP 10•2,5	20 (0.7874)
PLP 10•3,15	21 (0.8268)
PLP 10•4	22,4 (0.8819)
PLP 10•5	24 (0.9449)
PLP 10•5,8	25,3 (0.9961)
PLP 10•6,3	26 (1.0236)
PLP 10•8	28,75 (1.1319)
PLP 10•10	32 (1.2598)

Mounting flange type version 0	X
	mm (inch)
E1	14 (0.5512)
E7	14 (0.5512)
E8	14 (0.5512)
B1	14 (0.5512)
K2	11,8 (0.4646)
S0	17 (0.6693)
R8	41 (1.6142)
R9	41 (1.6142)
W9	41 (1.6142)

Replaces: 01/10.03

● 02/07.2006

POLARIS 20

MULTIPLE PUMPS

PLP 20

Replaces: 01/10.03

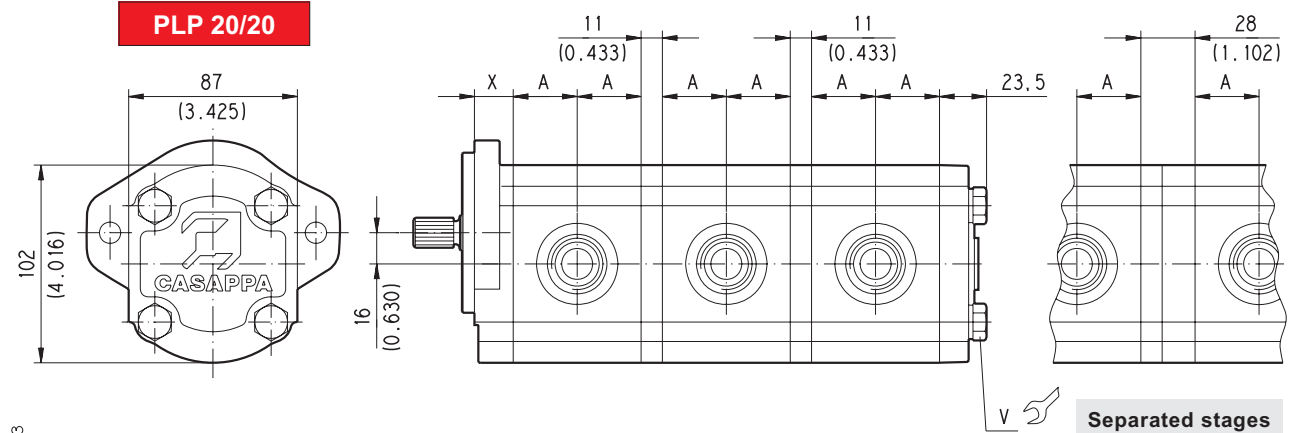

D033-261/0903

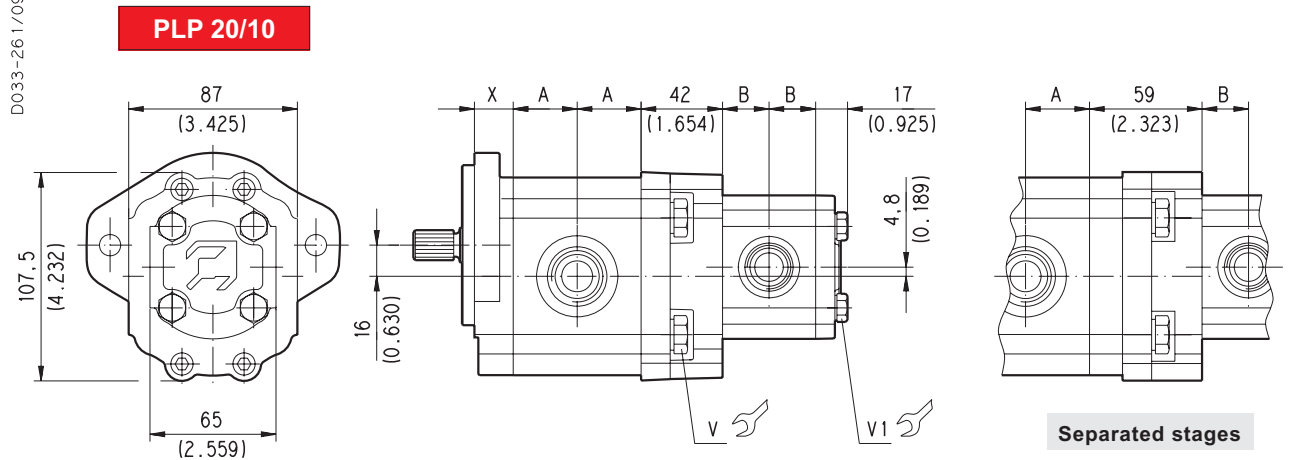

DRIVE SHAFTS: see page 52 ÷ 54
MOUNTING FLANGE: see page 60 ÷ 64

○ The rear cover is available in cast iron and aluminum.

Mounting flange material	Screws tightening torque Nm (lbf in)	
	V	V1
Aluminium	45 ^{±4.5} (358 ÷ 438)	25 ^{±2.5} (199 ÷ 243)
Cast iron	70 ^{±7} (558 ÷ 682)	-

Pump type	A
	mm (inch)
PLP 20•4	25,75 (1.0138)
PLP 20•6,3	27 (1.0630)
PLP 20•7,2	27,5 (1.0826)
PLP 20•8	28,25 (1.1122)
PLP 20•9	28,9 (1.1378)
PLP 20•10,5	30,25 (1.1909)
PLP 20•11,2	30,5 (1.2008)
PLP 20•14	33 (1.2992)
PLP 20•16	34,75 (1.3681)
PLP 20•19	36,45 (1.4350)
PLP 20•20	38 (1.4961)
PLP 20•24,5	40,8 (1.6063)
PLP 20•25	42 (1.6535)
PLP 20•27,5	43,35 (1.7067)
PLP 20•31,5	47 (1.8504)

Pump type	B
	mm (inch)
PLP 10•1	17,6 (0.6929)
PLP 10•1,5	18,4 (0.7244)
PLP 10•2	19,2 (0.7559)
PLP 10•2,5	20 (0.7874)
PLP 10•3,15	21 (0.8268)
PLP 10•4	22,4 (0.8819)
PLP 10•5	24 (0.9449)
PLP 10•5,8	25,3 (0.9961)
PLP 10•6,3	26 (1.0236)
PLP 10•8	28,75 (1.1319)
PLP 10•10	32 (1.2598)

Mounting flange type version 0	X
	mm (inch)
E2	18 (0.7087)
B2	18,8 (0.7402)
B4	16 (0.6299)
B5	16 (0.6299)
B6	17,7 (0.6969)
S1	20 (0.7874)
S2	20 (0.7874)
S9	20 (0.7874)
S5	20 (0.7874)
W8	32,1 (1.2638)

○ 02/07.2006

POLARIS 30

MULTIPLE PUMPS

PLP 30

PLP 30/30

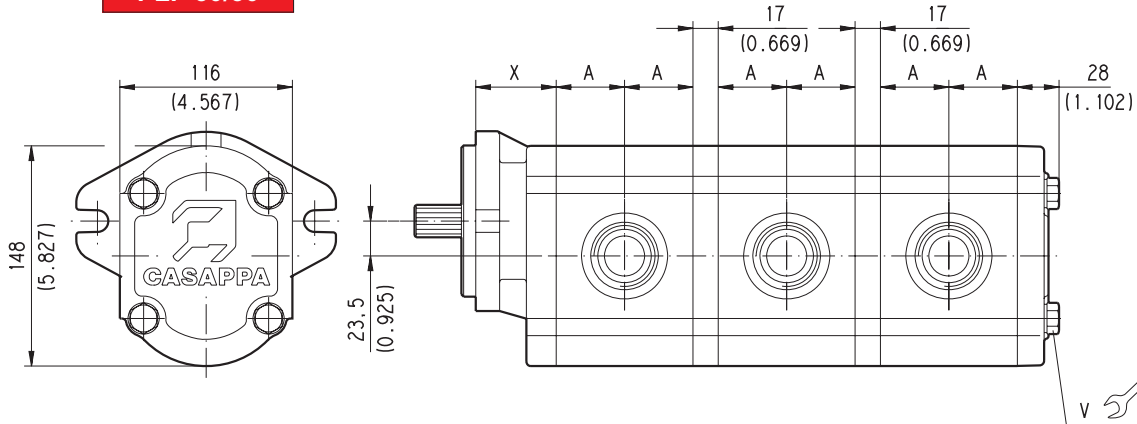

○ The rear cover is available in cast iron only.

PLP 30/20

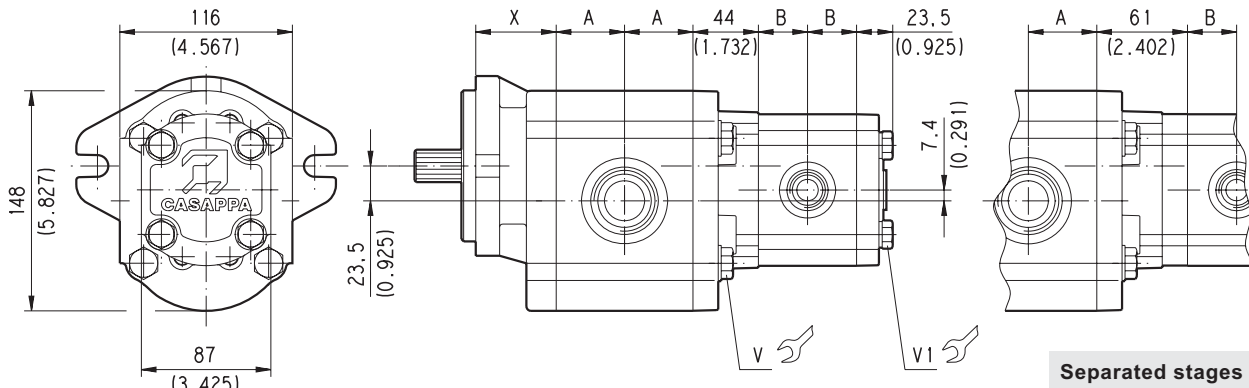

Separated stages

○ The rear cover is available in cast iron and aluminum.

PLP 30/10

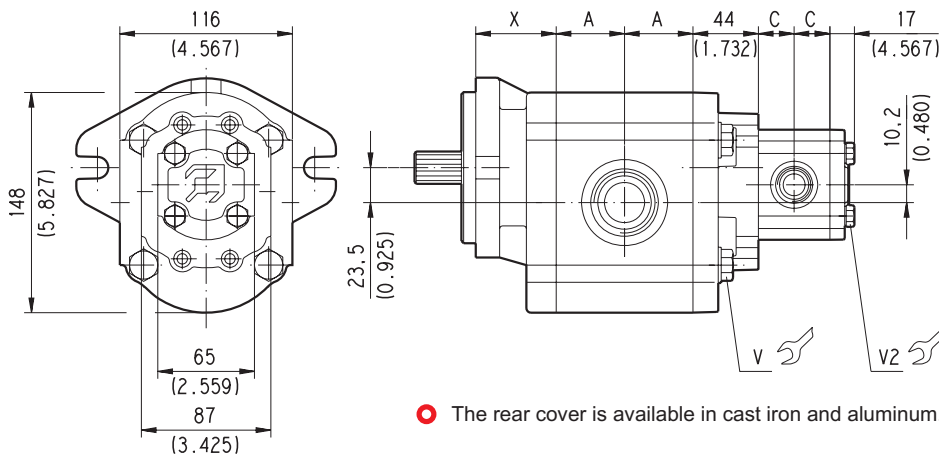

○ The rear cover is available in cast iron and aluminum.

D033-260/0903

Replaces: 01/10.03

○ 02/07.2006

POLARIS 30
MULTIPLE PUMPS
PLP 30

Replaces: 01/10.03

Pump type	A
	mm (inch)
PLP 30•22	39 (1.5354)
PLP 30•27	40,5 (1.5945)
PLP 30•34	43 (1.6929)
PLP 30•38	44,5 (1.7520)
PLP 30•43	46 (1.8110)
PLP 30•51	48,5 (1.9094)
PLP 30•61	51,5 (2.0276)
PLP 30•73	55,5 (2.1850)
PLP 30•82	58 (2.2835)
PLP 30•90	61 (2.4016)

Pump type	B
	mm (inch)
PLP 20•4	25,75 (1.0138)
PLP 20•6,3	27 (1.0630)
PLP 20•7,2	27,5 (1.0826)
PLP 20•8	28,25 (1.1122)
PLP 20•9	28,9 (1.1378)
PLP 20•10,5	30,25 (1.1909)
PLP 20•11,2	30,5 (1.2008)
PLP 20•14	33 (1.2992)
PLP 20•16	34,75 (1.3681)
PLP 20•19	36,45 (1.4350)
PLP 20•20	38 (1.4961)
PLP 20•24,5	40,8 (1.6063)
PLP 20•25	42 (1.6535)
PLP 20•27,5	43,35 (1.7067)
PLP 20•31,5	47 (1.8504)

Pump type	C
	mm (inch)
PLP 10•1	17,6 (0.6929)
PLP 10•1,5	18,4 (0.7244)
PLP 10•2	19,2 (0.7559)
PLP 10•2,5	20 (0.7874)
PLP 10•3,15	21 (0.8268)
PLP 10•4	22,4 (0.8819)
PLP 10•5	24 (0.9449)
PLP 10•5,8	25,3 (0.9961)
PLP 10•6,3	26 (1.0236)
PLP 10•8	28,75 (1.1319)
PLP 10•10	32 (1.2598)

DRIVE SHAFTS: see page 55 and page 56

MOUNTING FLANGE: see page 65 ÷ 67

Mounting flange type version 0	X
	mm (inch)
E3	24 (0.945)
E4	25 (0.984)
B3	28 (1.102)
S5	54 (2.1260)
U3	20,8 (0.819)

02/07.2006

Mounting flange material	Screws tightening torque Nm (lbf in)		
	V	V1	V2
Aluminium	–	45 ^{±4,5} (358 ÷ 438)	25 ^{±2,5} (199 ÷ 243)
Cast iron	100 ^{±10} (797 ÷ 974)	–	–

VERSIONS

For each version, the possible combination between drive shafts and mounting flanges are shown on pages 57 ÷ 67.

VERSION	0		
Available for group:			
10	20	30	

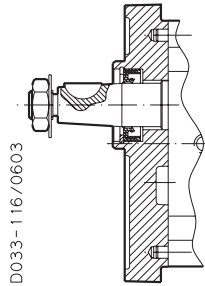

Version for applications without radial and axial load on the drive shaft.

VERSION	W8	
Available for group:		
20		

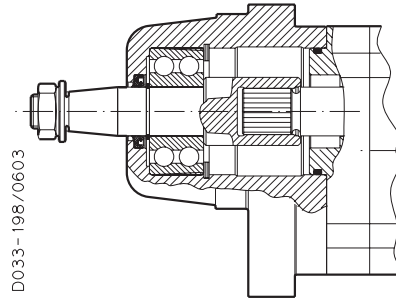

VERSION	4	
Available for group:		
20		

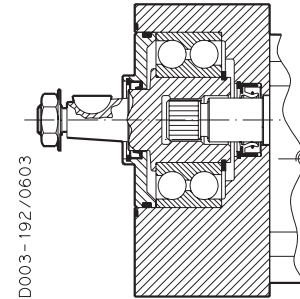

VERSION	5	
Available for group:		
20		

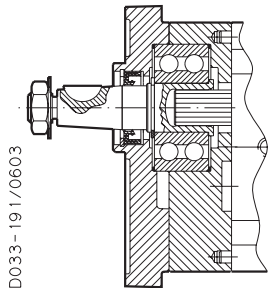

VERSION	6	
Available for group:		
20		

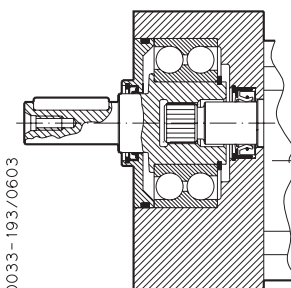

VERSION	7	
Available for group:		
20		

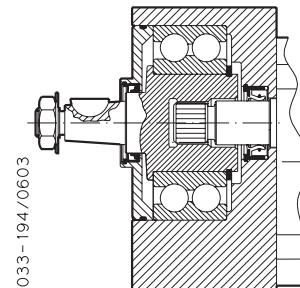

VERSION	8	
Available for group:		
20		

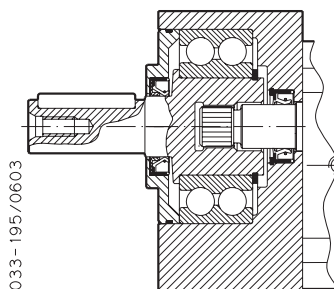

VERSION	9	
Available for group:		
20		

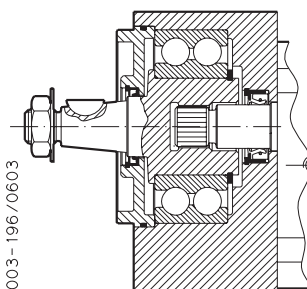

For the outboard bearing life expectancy, diagrams providing approximate selection data will be found on subsequent pages. For particular applications please consult our technical sales department.

01/10.03

POLARIS 20

VERSION WITH OUTBOARD BEARING

W8

Replaces: 01/10.03

D033-197/0603

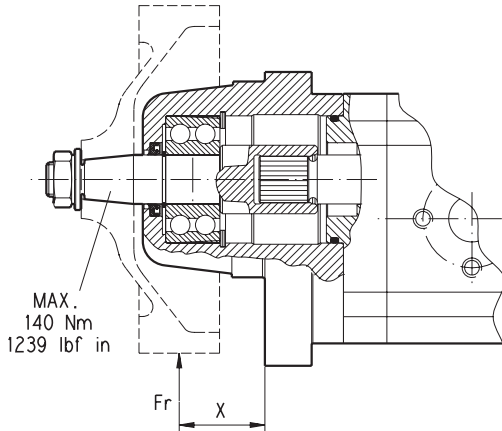

X= Distance of the radial load result from the mounting flange [mm (in)].

Each curve has been obtained at:
Lubricant oil ISO VG 46
Temperature 60 °C (140 °F)
Without or with very low axial load

Example

Fr Radial load	1915 N (430.88 lbf)
X	20 mm (0.7874 in)
Speed	2000 min ⁻¹
Rating fatigue life	≈ 2000 h

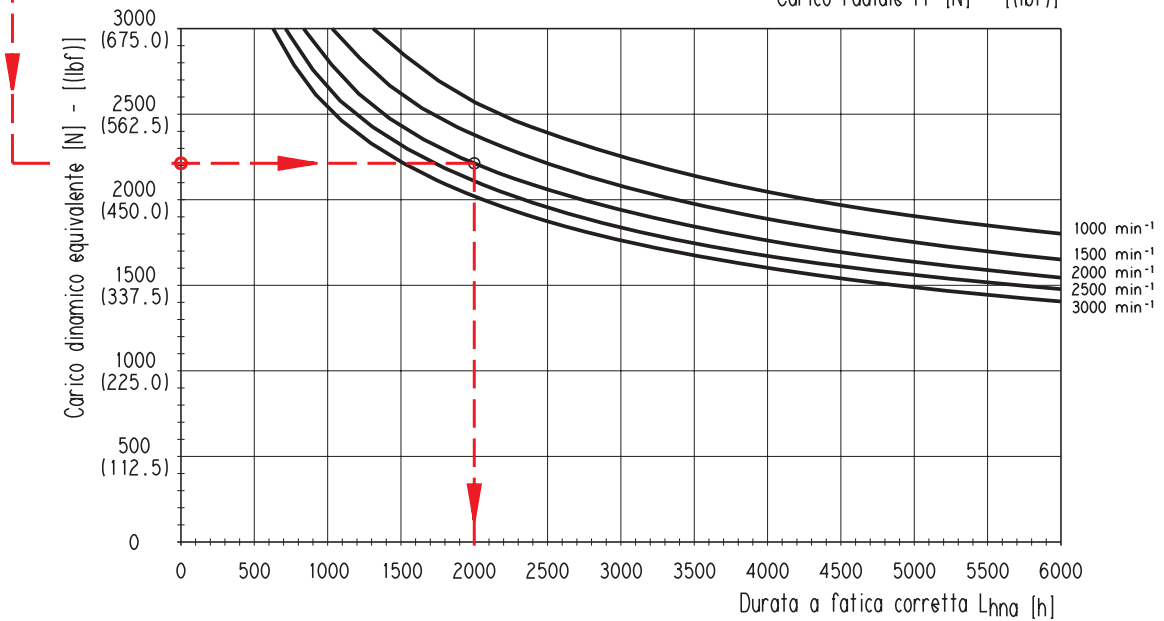
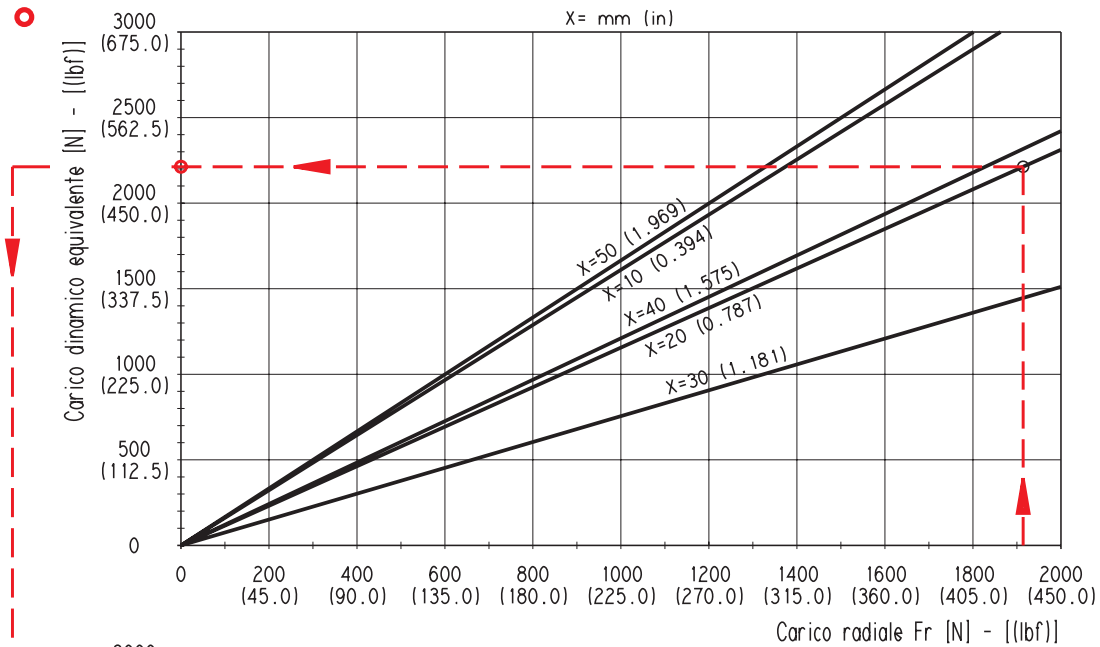

02/07.2006

D033-124/0606

D003-114/0603

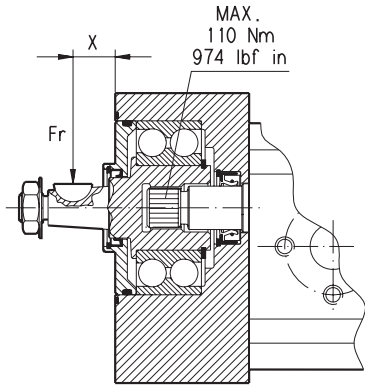

X = Distance of the radial load result from the mounting flange [mm (in)].

Each curve has been obtained at:
 Lubricant oil ISO VG 46
 Temperature 60 °C (140 °F)
 Without or with very low axial load

Example

Fr Radial load	1850 N (416.25 lbf)
X	20 mm (0.7874 in)
Speed	2000 min ⁻¹
Rating fatigue life	≈ 2000 h

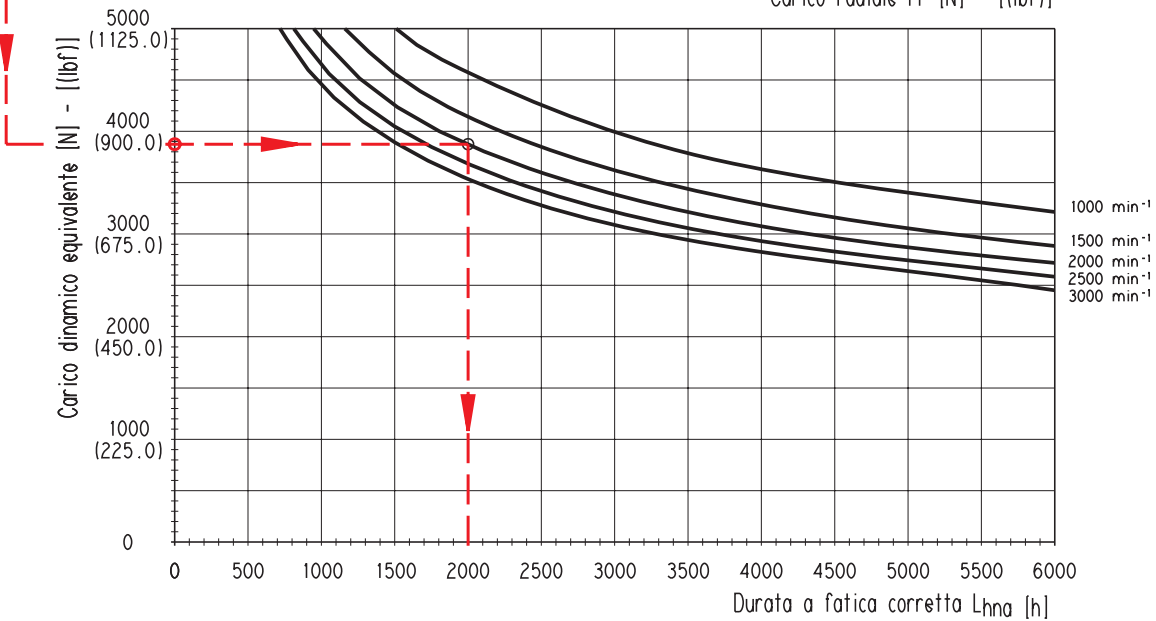
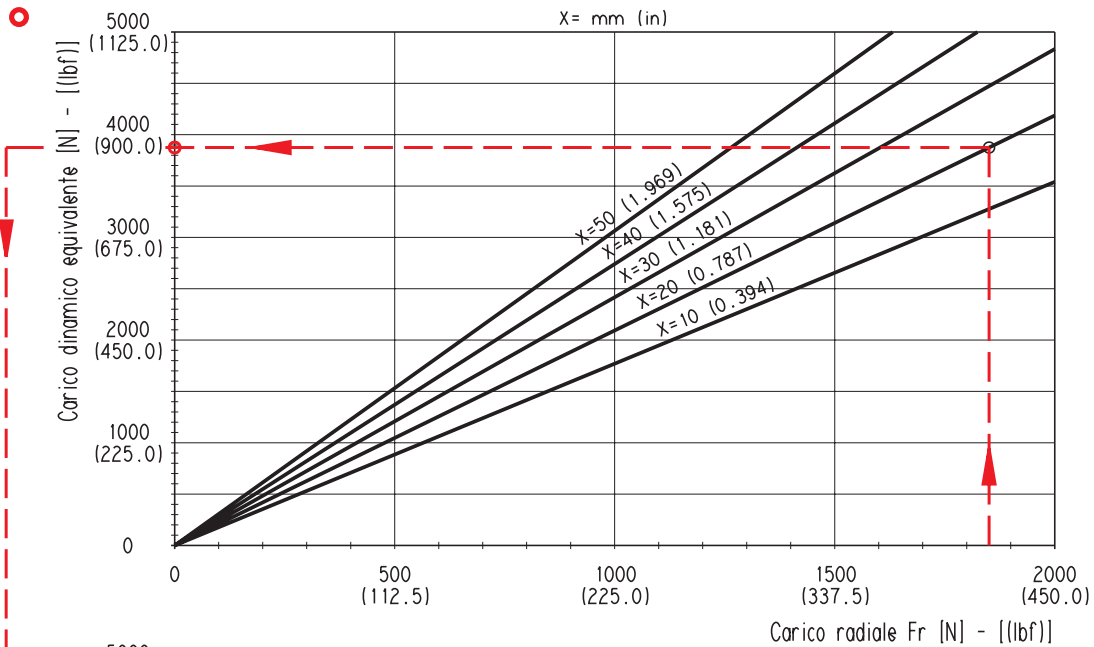

D033-122/0606

Replaces: 01/10.03

02/07.2006

Replaces: 01/10.03

D033-115/0603

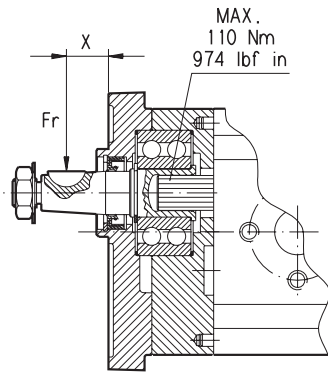

X= Distance of the radial load result from the mounting flange [mm (in)].

Each curve has been obtained at:
Lubricant oil ISO VG 46
Temperature 60 °C (140 °F)
Without or with very low axial load

Example

Fr Radial load	800 N (180 lbf)
X	20 mm (0.7874 in)
Speed	2000 min ⁻¹
Rating fatigue life	≈ 2000 h

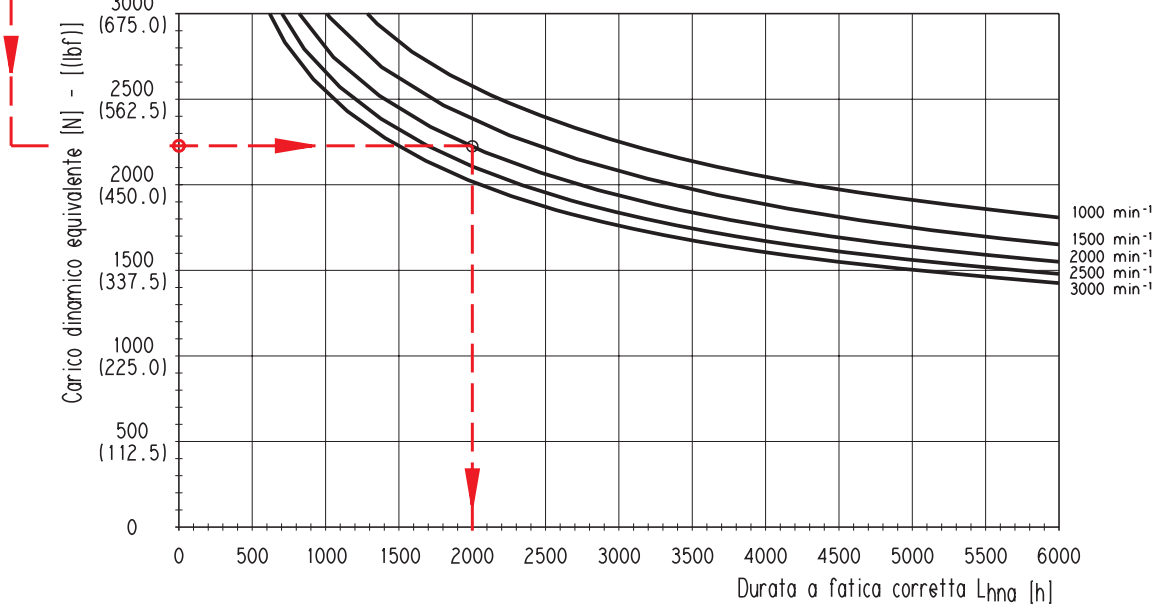
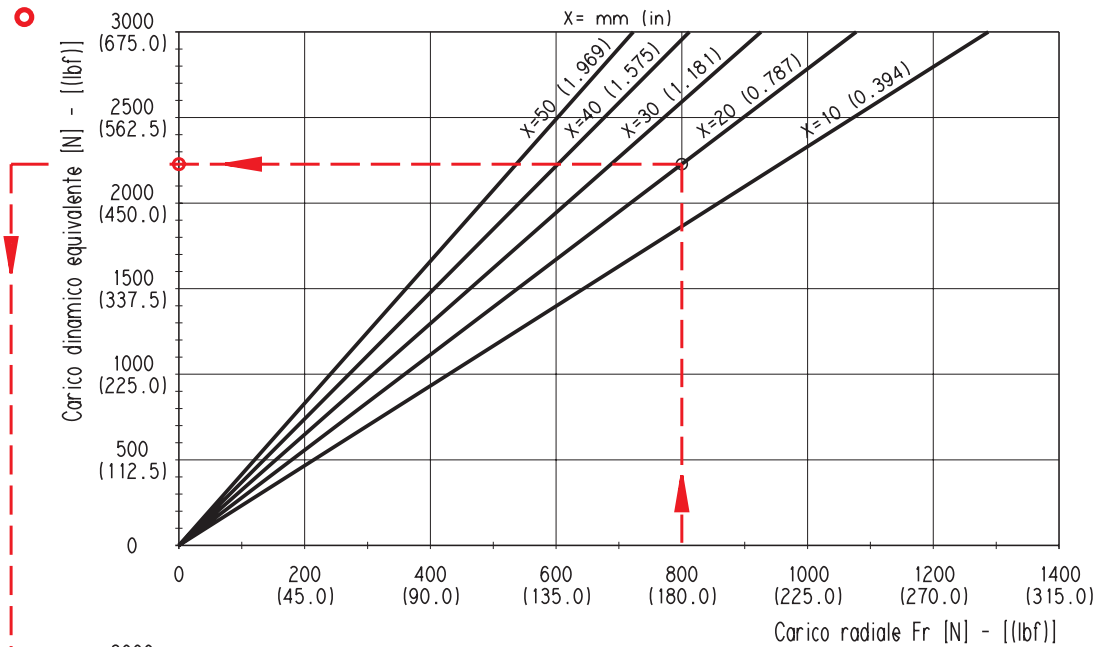

02/07.2006

D033-121/0606

D033-118/0603

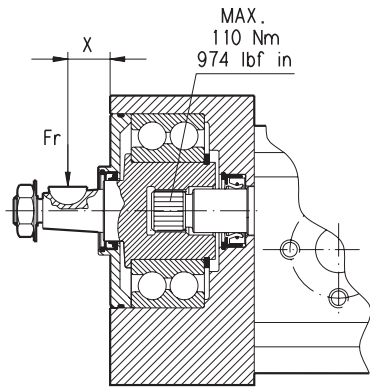

X= Distance of the radial load result from the mounting flange [mm (in)].

Each curve has been obtained at:
Lubricant oil ISO VG 46
Temperature 60 °C (140 °F)
Without or with very low axial load

Example

Fr Radial load	1858 N (524.25 lbf)
X	20 mm (0.787 in)
Speed	2000 min ⁻¹
Rating fatigue life	≈ 2000 h

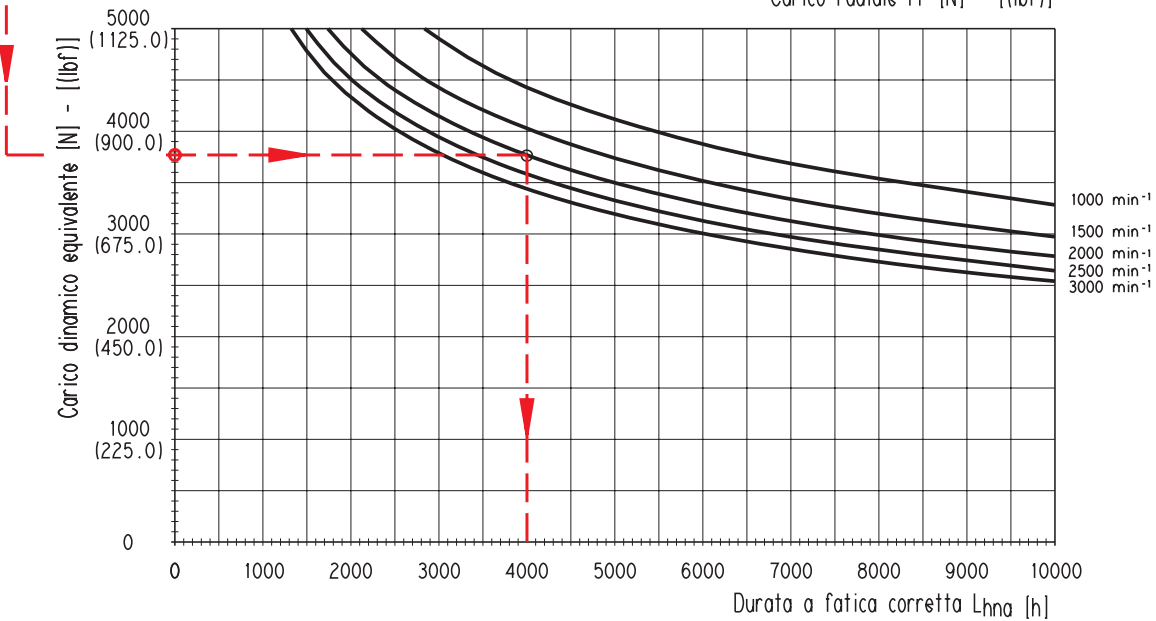
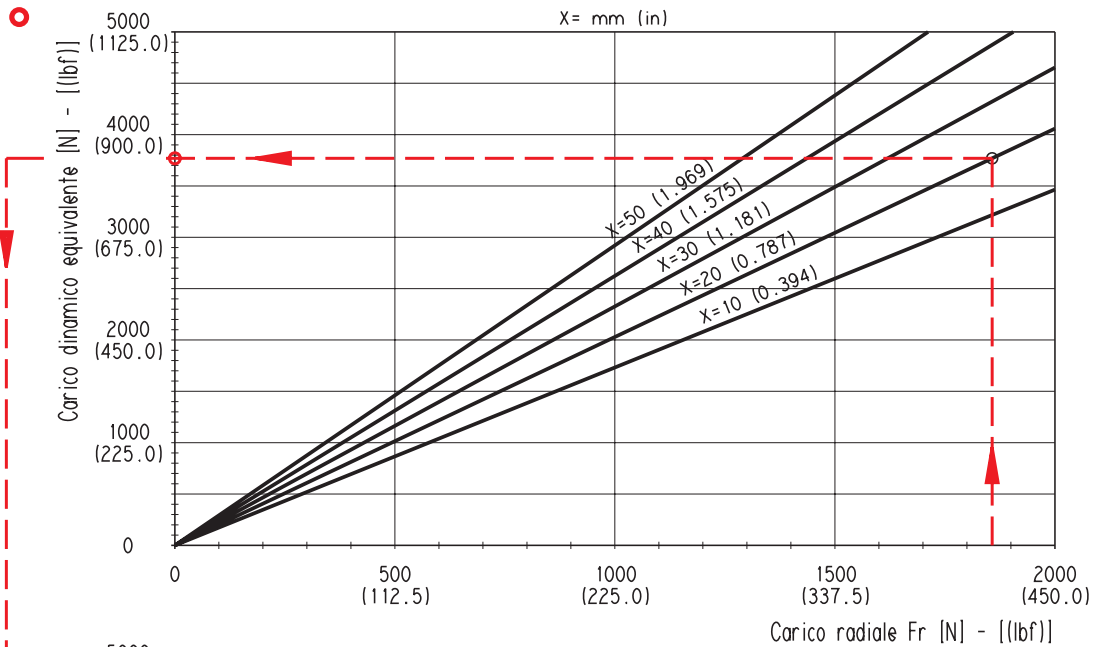

D033-123/0606

Replaces: 01/10.03

02/07.2006

POLARIS 10

DRIVE SHAFTS

EUROPEAN TAPERED 1:8

81

Mounting face refer to flange code **E1**

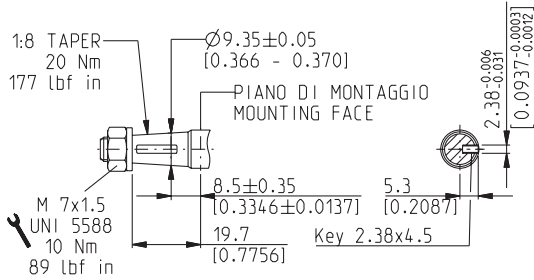

DCAT_033_041

EUROPEAN TAPERED 1:8

86

Mounting face refer to flange code **E7**

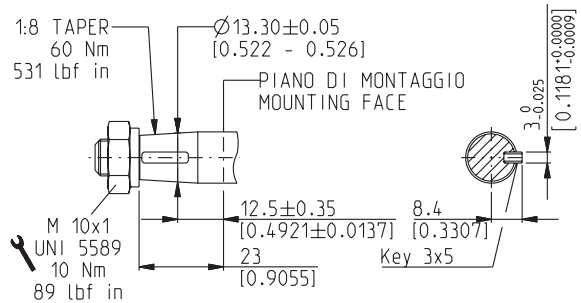

DCAT_033_042

SAE "AA" SPLINE

02

Not available with size:

10•8	With flange: E1, E8, K2, S0
10•1,5 - 10•2,5 - 10•5,8	With flange: R8, R9

Mounting face refer to flange code **R9**

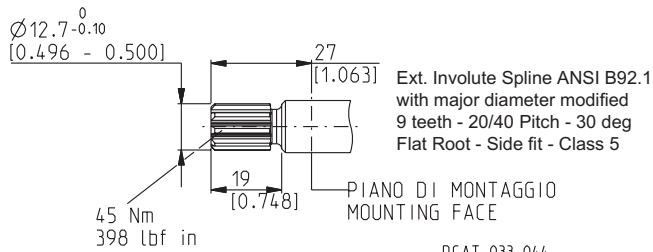

DCAT_033_044

SAE "AA" STRAIGHT

30

Not available with size:

10•1,5 - 10•2,5 - 10•5,8	With flange: E7, B1, K2, R8, R9
10•2,5 - 10•5,8	With flange: S0

Mounting face refer to flange code **S0**

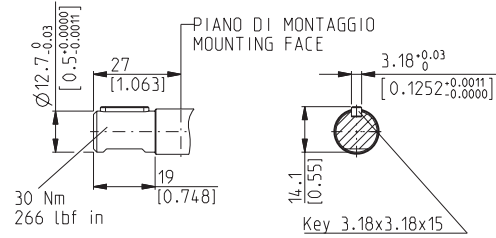

DCAT_033_045

SAE STRAIGHT

36

Not available with size:

10•1,5 - 10•2,5

Mounting face refer to flange code **R8**

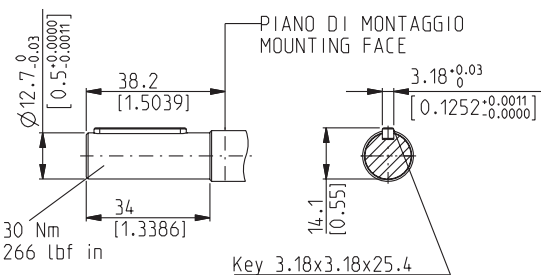

DCAT_033_046

STRAIGHT

29

Not available with size:

10•5,8

Mounting face refer to flange code **E8**

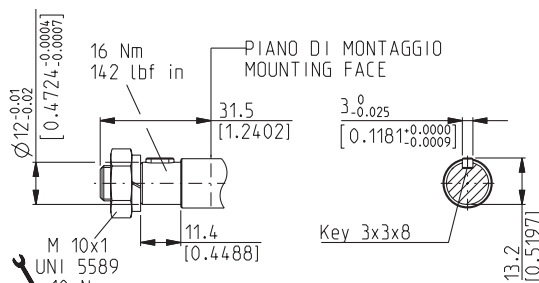

DCAT_033_043

01/10.03

POLARIS 20

DRIVE SHAFTS

EUROPEAN TAPERED 1:8

82

Not available with size:

20•10,5 - 20•24,5 - 20•27,8

Mounting face refer to flange code **E2**

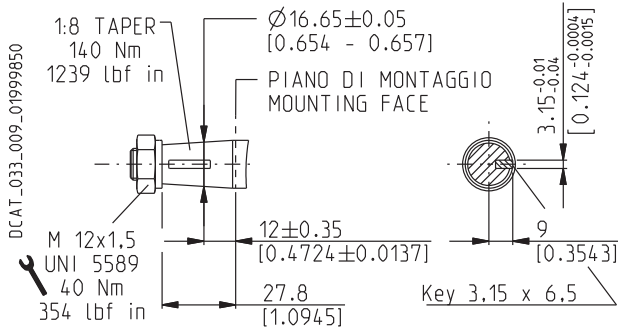

GERMAN TAPERED 1:5

54

Not available with size:

20•7,2 - 20•10,5 - 20•19 - 20•24,5 - 20•27,8 - 20•31,5

Mounting face refer to flange code **B2**

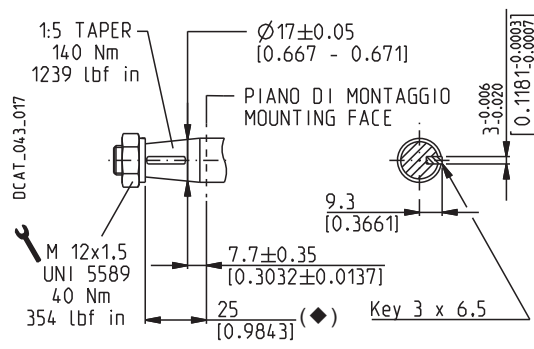

(◆) 27.5 [1.0827] with flanges code **B4** and **B5**

GERMAN TAPERED 1:5

55

Only for version **5, 9** and **W8** with outboard bearing

Mounting face refer to flange code **B2**

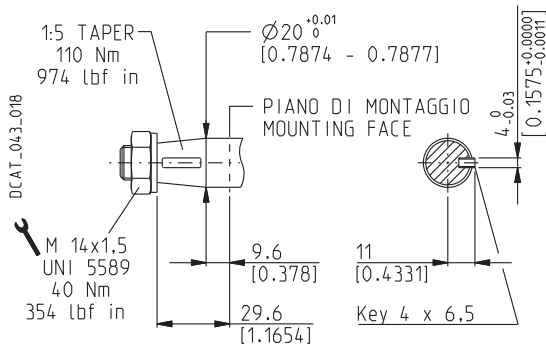

STRAIGHT

46

Not available with size:

20•7,2 - 20•10,5 - 20•19 - 20•24,5 - 20•25 - 20•27,8 - 20•31,5

Mounting face refer to flange code **E2**

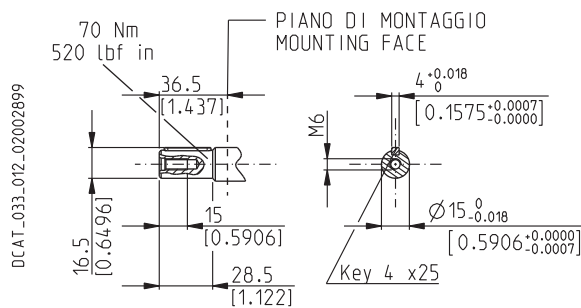

SAE "A" SPLINE

03

Not available with size:

20•24,5 - 20•27,8

Mounting face refer to flange code **S1**

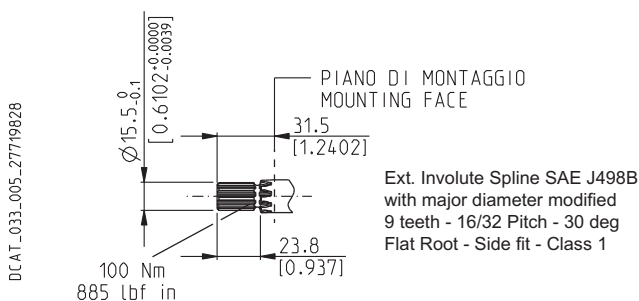

Ext. Involute Spline SAE J498B with major diameter modified 9 teeth - 16/32 Pitch - 30 deg Flat Root - Side fit - Class 1

SPLINE

01

Not available with size:

20•6,3 - 20•9 - 20•10,5 - 20•19

Mounting face refer to flange code **S1**

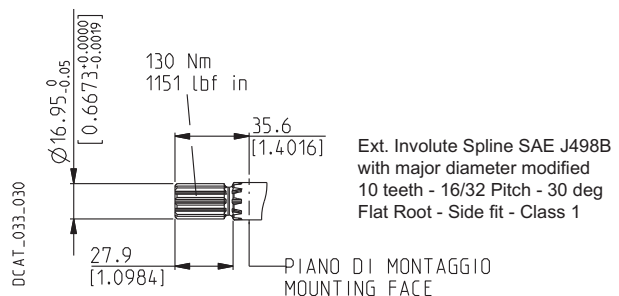

Ext. Involute Spline SAE J498B with major diameter modified 10 teeth - 16/32 Pitch - 30 deg Flat Root - Side fit - Class 1

01/10.03

POLARIS 20

DRIVE SHAFTS

SAE SPLINE

07

Not available with size:

20•7,2 - 20•10,5 - 20•19 - 20•24,5 - 20•27,8

Mounting face refer to flange code **S1**

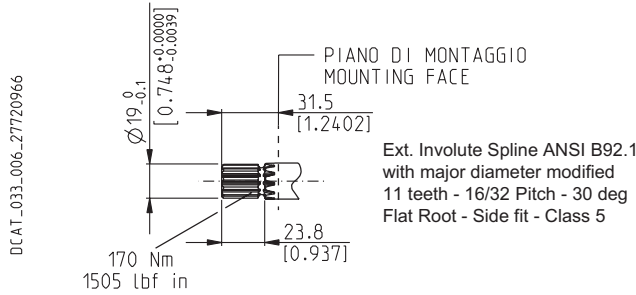

SAE "A" STRAIGHT

31

Not available with size:

20•10,5 - 20•19 - 20•24,5 - 20•27,8

Mounting face refer to flange code **S1**

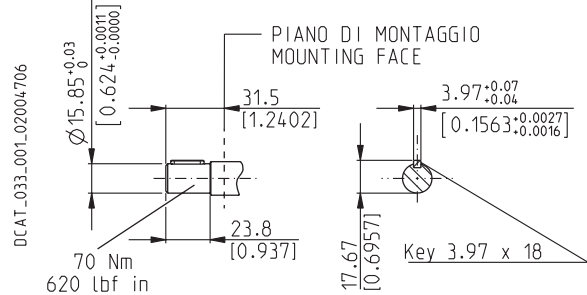

STRAIGHT

49

Not available with size:

20•7,2 - 20•19 - 20•24,5

Mounting face refer to flange code **S1**

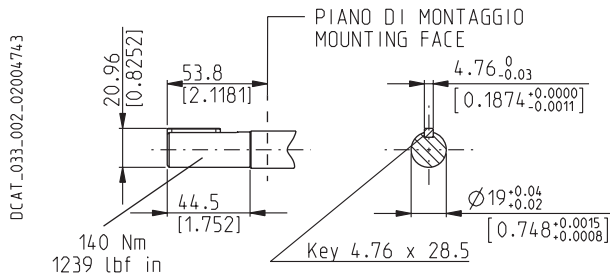

STRAIGHT

50

Not available with size:

20•7,2 - 20•10,5 - 20•19 - 20•24,5 - 20•27,8

Mounting face refer to flange code **S1**

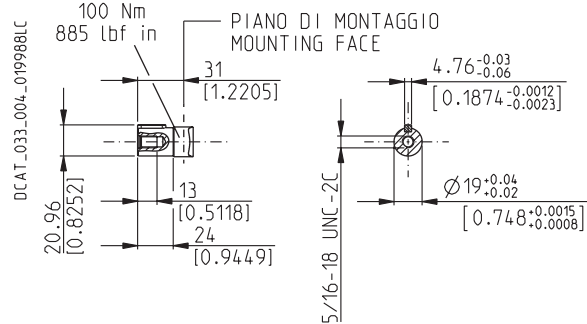

SAE "B" SPLINE

04

Not available with size:

20•4 - 20•7,2 - 20•10,5 - 20•24,5 - 20•27,8

Mounting face refer to flange code **S5**

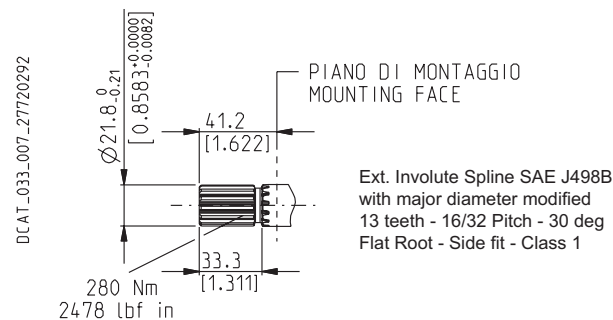

SAE "B" STRAIGHT

32

Not available with size:

20•4 - 20•7,2 - 20•8 - 20•10,5 - 20•11,2

20•19 - 20•24,5 - 20•27,8

Mounting face refer to flange code **S5**

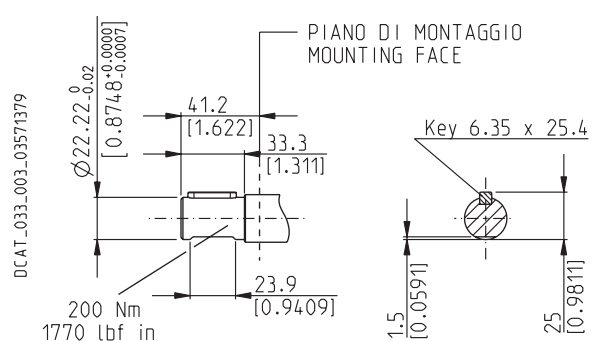

01/10.03

POLARIS 20

DRIVE SHAFTS

DIN 5482 SPLINE

12

Not available with size:

20•10,5 - 20•19 - 20•24,5 - 20•27,8

Mounting face refer to flange code **B2**

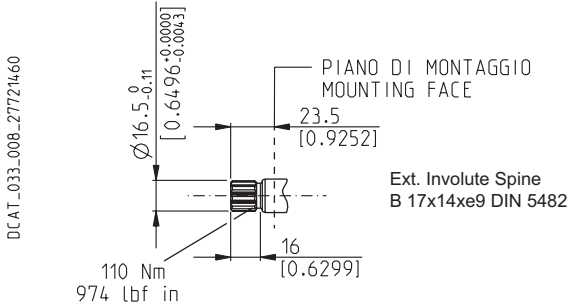

STRAIGHT

48

Only for version **6** with outboard bearing

Available in 0 version only with size:

20•20

Mounting face refer to flange code **E2**

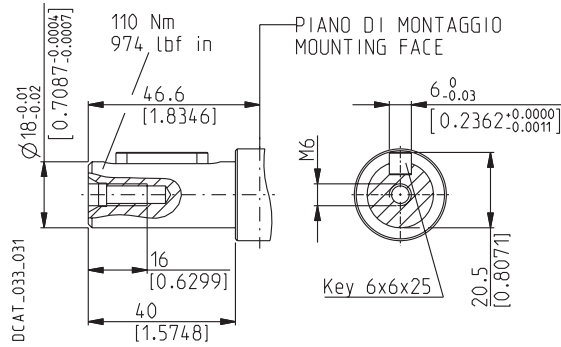

STRAIGHT

B1

Only for version **8** and **5** with outboard bearing

Mounting face refer to flange code **E2**

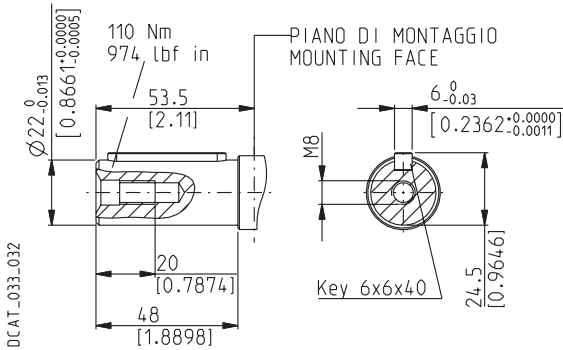

TANG

95

Not available with size:

20•7,2 - 20•10,5 - 20•19 - 20•24,5 - 20•27,8

Mounting face refer to flange code **B6**

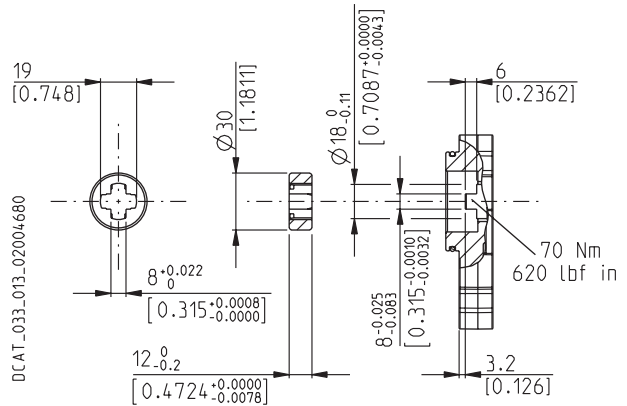

POLARIS 30

DRIVE SHAFTS

EUROPEAN TAPERED 1:8

83

Not available with size:

30•82 - 30•90

Mounting face refer to flange code **E3**

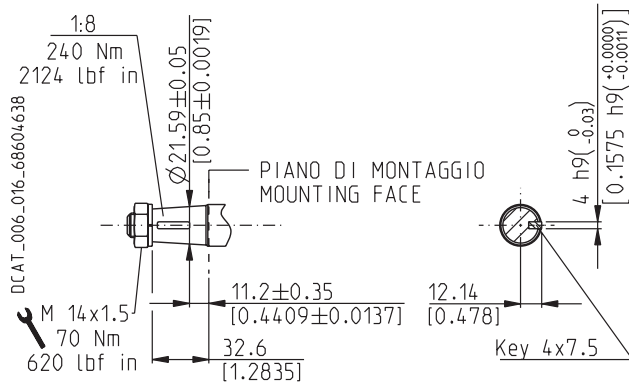

EUROPEAN TAPERED 1:8

84

Not available with size:

30•22 - 30•27 - 30•34 - 30•38

Mounting face refer to flange code **E4**

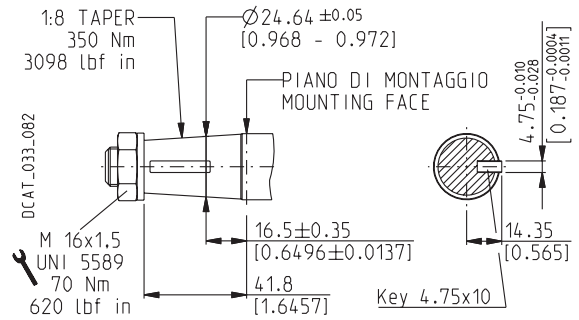

GERMAN TAPERED 1:5

56

Not available with size:

30•61 - 30•73 - 30•82 - 30•90

Mounting face refer to flange code **B3**

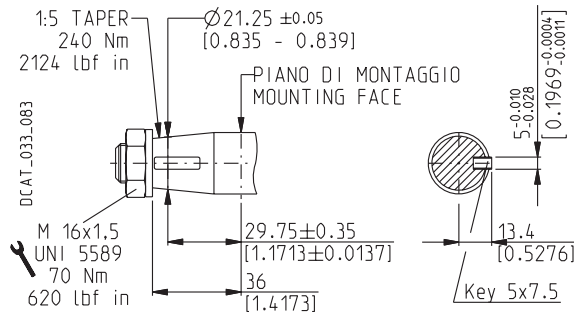

STRAIGHT

41

Not available with size:

30•82 - 30•90

Mounting face refer to flange code **E3**

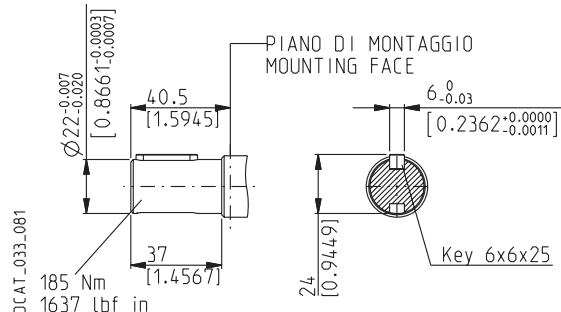

SAE "B" SPLINE

A8

Not available with size:

30•82 - 30•90

Mounting face refer to flange code **U3**

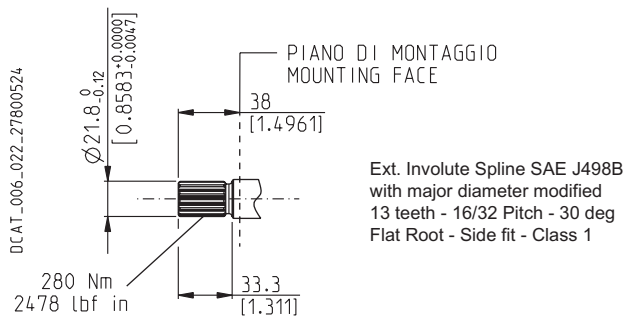

SAE "BB" SPLINE

A5

Not available with size:

30•22 - 30•38 - 30•82 - 30•90

Mounting face refer to flange code **U3**

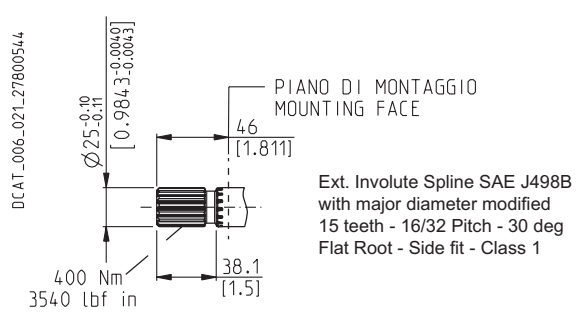

01/10.03

POLARIS 30

DRIVE SHAFTS

SAE "B" SPLINE

04

Mounting face refer to flange code **S5**

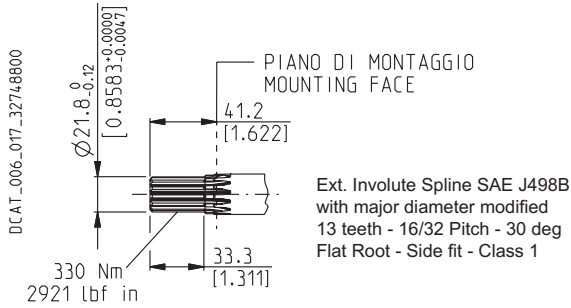

SAE "BB" SPLINE

05

Not available with size:

30•90

Mounting face refer to flange code **S5**

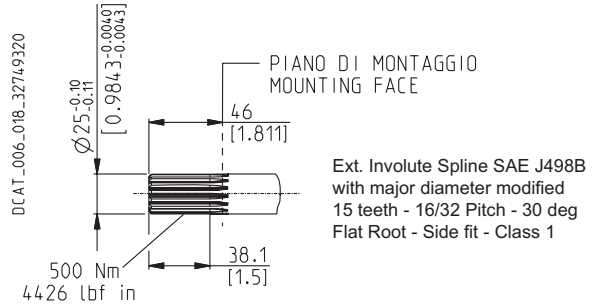

SAE "B" STRAIGHT

32

Mounting face refer to flange code **S5**

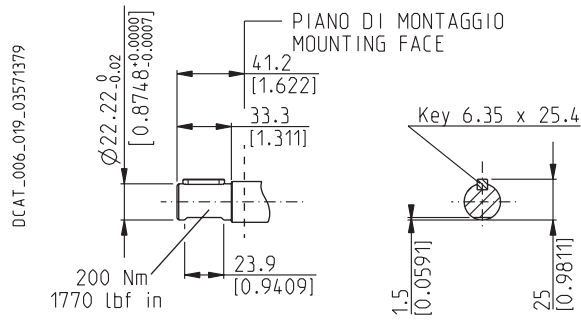

SAE "BB" STRAIGHT

33

Mounting face refer to flange code **S5**

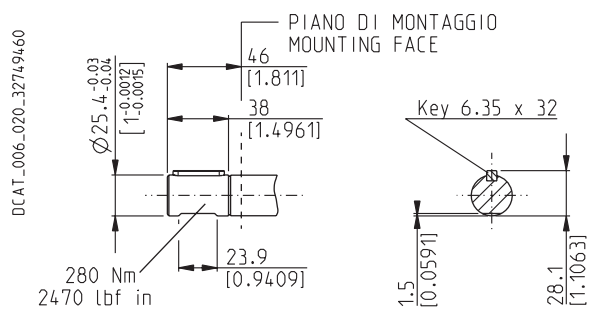

01/10.03

POLARIS 10

MOUNTING FLANGES AND TABLE OF COMPATIBILITY

Replaces: 01/10.03

EUROPEAN E1

Material: cast iron and aluminium

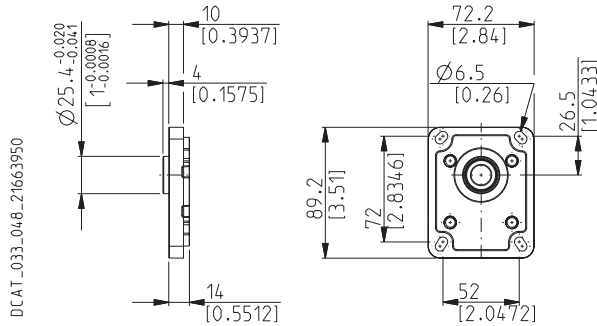

VERSIONS See page 46	DRIVE SHAFTS See page 51			
	81	02	29	86
0	#	x	x	x

Standard combination
x Available combination

EUROPEAN E7

Material: cast iron and aluminium

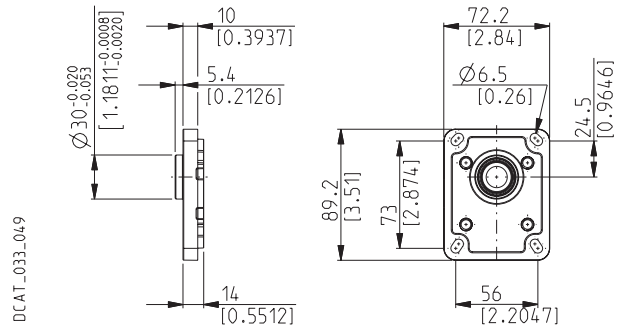

VERSIONS See page 46	DRIVE SHAFTS See page 51		
	86	29	30
0	#	x	x

Standard combination
x Available combination

EUROPEAN E8

Material: cast iron and aluminium

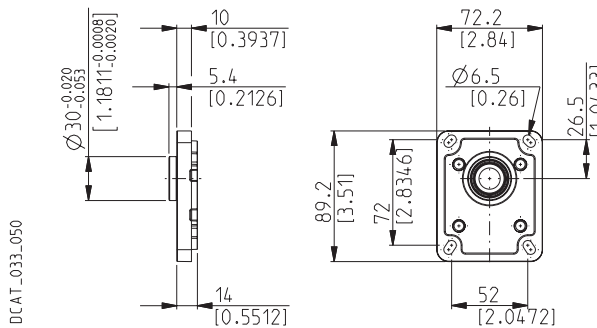

VERSIONS See page 46	DRIVE SHAFTS See page 51	
	29	02
0	#	x

Standard combination
x Available combination

GERMAN 2 BOLTS B1

Material: aluminium

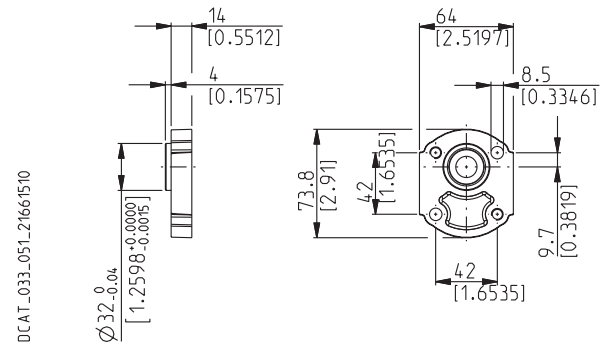

VERSIONS See page 46	DRIVE SHAFTS See page 51	
	30	86
0	#	x

Standard combination
x Available combination

02/07.2006

POLARIS 10

MOUNTING FLANGES AND TABLE OF COMPATIBILITY

GERMAN 4 BOLTS

K2

Material: aluminium

DCAT_033_052_21664100

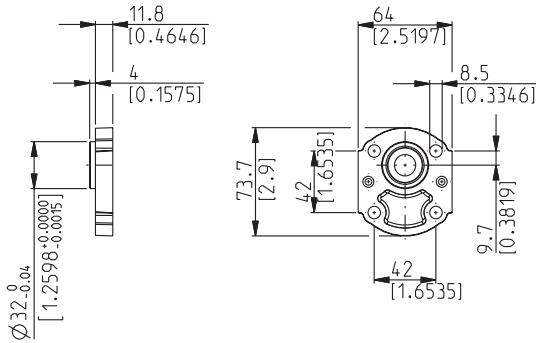

DRIVE SHAFTS
See page 51

VERSIONS See page 46	02	30
0	x	x

Standard combination
x Available combination

SAE "A-A" 2 BOLTS

S0

Material: cast iron and aluminium

DCAT_033_053_21664000

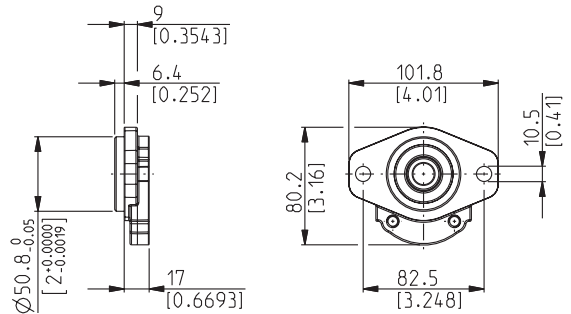

DRIVE SHAFTS
See page 51

VERSIONS See page 46	30	02	86
0	#	x	x

Standard combination
x Available combination

SAE "A-A" 2-4 BOLTS

R9

Material: cast iron

DCAT_033_055

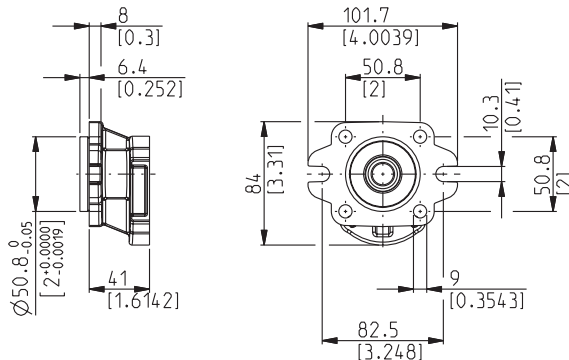

DRIVE SHAFTS
See page 51

VERSIONS See page 46	02	30	36
0	#	x	#

Standard combination
x Available combination

SAE 2-4 BOLTS

R8

Material: cast iron

DCAT_033_054_21662200

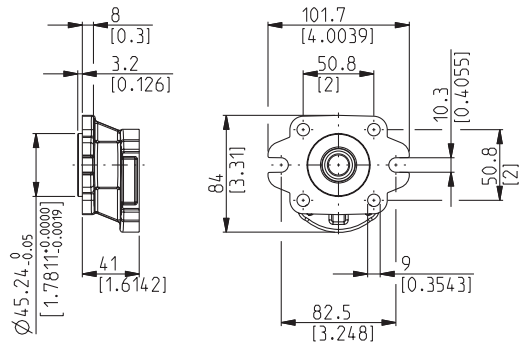

DRIVE SHAFTS
See page 51

VERSIONS See page 46	02	30	36
0	#	x	#

Standard combination
x Available combination

Replaces: 01/10.03

02/07.2006

POLARIS 10

MOUNTING FLANGES AND TABLE OF COMPATIBILITY

SAE 2 BOLTS

W9

Material: cast iron

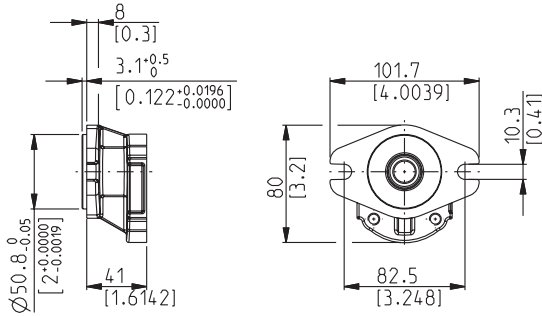

DCAT_033_057_21662215

Replaces: 01/10.03

DRIVE SHAFTS
See page 51

VERSIONS See page 46	36
0	#

Standard combination
x Available combination

02/07.2006

POLARIS 20

MOUNTING FLANGES AND TABLE OF COMPATIBILITY

EUROPEAN

E2

Material: cast iron and aluminium

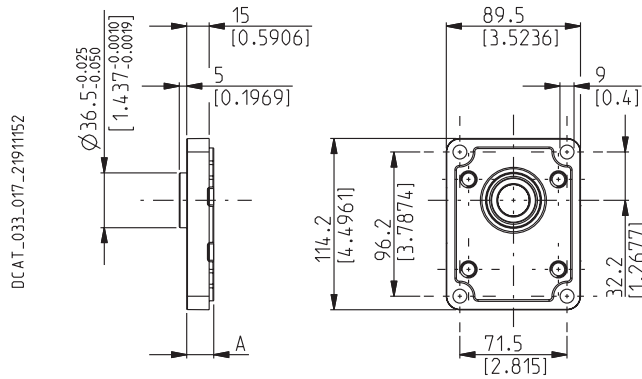

VERSIONS See page 46	A mm (in)	DRIVE SHAFTS See page 52 ÷ 54											
		82	46	B1	03	04	07	12	31	48	49	50	54
0	18 (0.7087)	#	#		x	x	x	x	x	x	x	x	x
4	55,4 (2.1811)	#											
5	43,6 (1.7165)	#		x	x						x	x	x
6	55,4 (2.1811)									#			
7	59,4 (2.3386)	#											
8	59,4 (2.3386)			#									

Standard combination
x Available combination

GERMAN

B2

Material: cast iron and aluminium

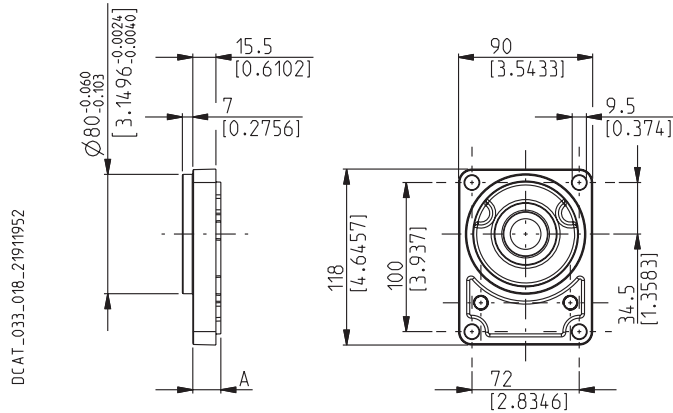

VERSIONS See page 46	A mm (in)	DRIVE SHAFTS See page 52 ÷ 54								
		12	54	55	01	03	31	46	49	82
0	18,8 (0.7402)	#	#		x	x	x	x	x	x
5	44,4 (1.7480)		x	x		x			x	x
9	59,4 (1.7441)			x						

Standard combination
x Available combination

Replaces: 01/10.03

02/07.2006

POLARIS 20

MOUNTING FLANGES AND TABLE OF COMPATIBILITY

GERMAN 2 BOLTS

B4

Material: cast iron and aluminium



DCAT_033_020_21912051

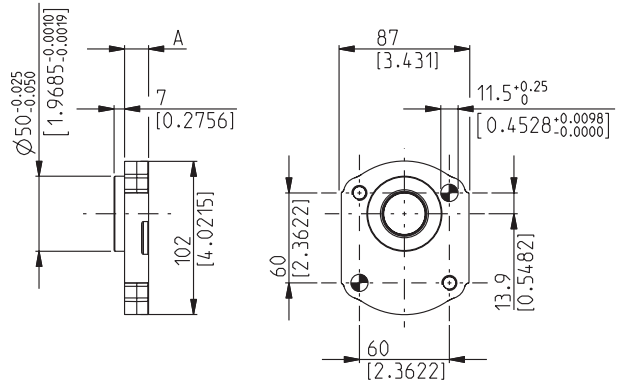

		DRIVE SHAFTS See page 52 ÷ 54						
VERSIONS See page 46	A mm (in)	54	03	12	31	49	54	82
0	16 (0.63)	#	x	x	x	x	x	x
5	41,6 (1.6378)	x	x			x	x	x

Standard combination
x Available combination

GERMAN 2 BOLTS

B5

Material: cast iron and aluminium



DCAT_033_021_21912256

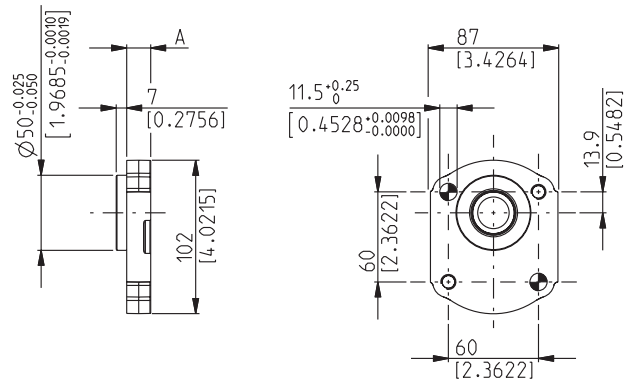

		DRIVE SHAFTS See page 52 ÷ 54						
VERSIONS See page 46	A mm (in)	54	03	12	31	49	54	82
0	16 (0.63)	#	x	x	x	x	x	x
5	41,6 (1.6378)	x	x			x	x	x

Standard combination
x Available combination

Replaces: 01/10.03

02/07.2006

POLARIS 20

MOUNTING FLANGES AND TABLE OF COMPATIBILITY

GERMAN 4 BOLTS

B6

Material: cast iron and aluminium ●

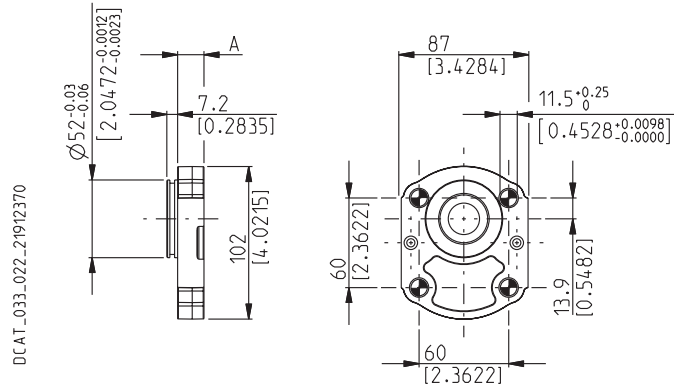

DRIVE SHAFTS
See page 52 ÷ 54

VERSIONS See page 46	A mm (in)	95	07	12
0	17,7 (0.6968)	#	x	x
5	43,3 (1.747)	x		

Standard combination
x Available combination

SAE "A" 2 BOLTS

S1

Material: cast iron and aluminium ●

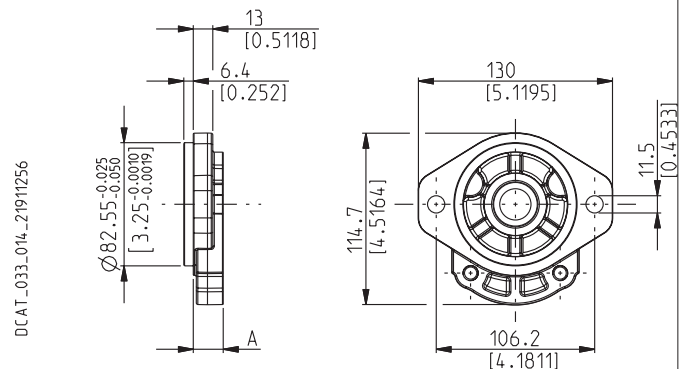

DRIVE SHAFTS
See page 52 ÷ 54

VERSIONS See page 46	A mm (in)	01	03	04	07	12	31	32	46	49	50	54	82
0	20 (0.787)	#	#	x	#	x	#	x	x	#	x	x	x
5	45,6 (1.7953)		x							x	x	x	x

Standard combination
x Available combination

Replaces: 01/10.03

● 02/07.2006

POLARIS 20

MOUNTING FLANGES AND TABLE OF COMPATIBILITY

SAE "A" 2 BOLTS

S2

Material: cast iron and aluminium

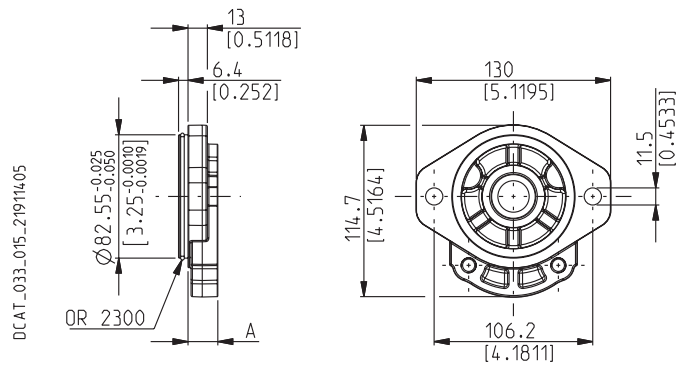

DRIVE SHAFTS

See page 52 ÷ 54

VERSIONS See page 46	A mm (in)	01	03	04	07	12	31	32	46	49	50	54	82
0	20 (0.7874)	#	#	x	#	x	#	x	x	#	x	x	x
5	45,6 (1.7953)		x							x	x	x	x

Standard combination
x Available combination

SAE "A" 2 BOLTS

S9

Material: cast iron and aluminium

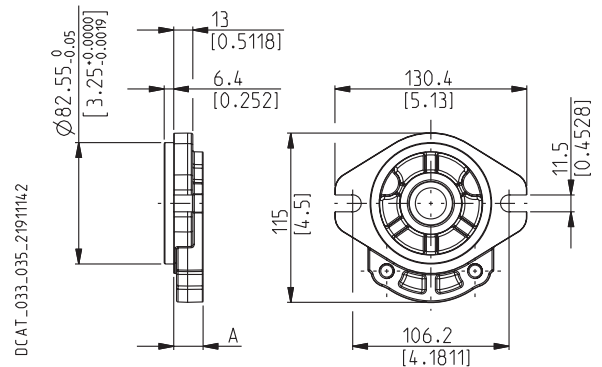

DRIVE SHAFTS

See page 52 ÷ 54

VERSIONS See page 46	A mm (in)	01	03	04	07	12	31	32	46	49	50	54	82
0	20 (0.7874)	#	#	x	#	x	#	x	x	#	x	x	x
5	45,6 (1.7953)		x							x	x	x	x

Standard combination
x Available combination

Replaces: 01/10.03

02/07.2006

POLARIS 20

MOUNTING FLANGES AND TABLE OF COMPATIBILITY

SAE "B" 2 BOLTS

S5

Material: cast iron

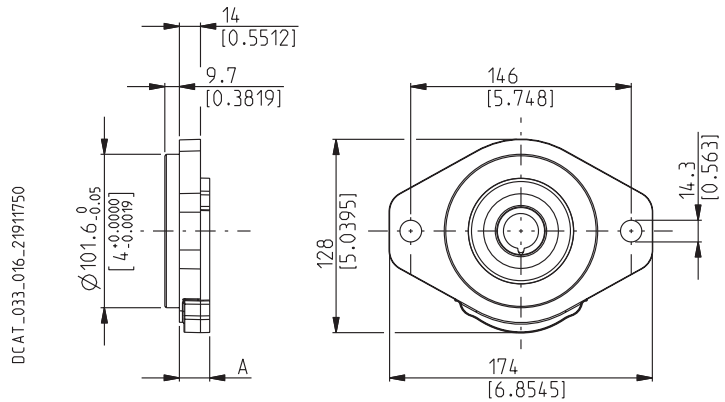

DRIVE SHAFTS

See page 52 ÷ 54

VERSIONS See page 46	A mm (in)	04	32	49
0	20 (0.7874)	#	#	x
5	45,6 (1.7953)			x

Standard combination
x Available combination

GERMAN

W8

Material: cast iron

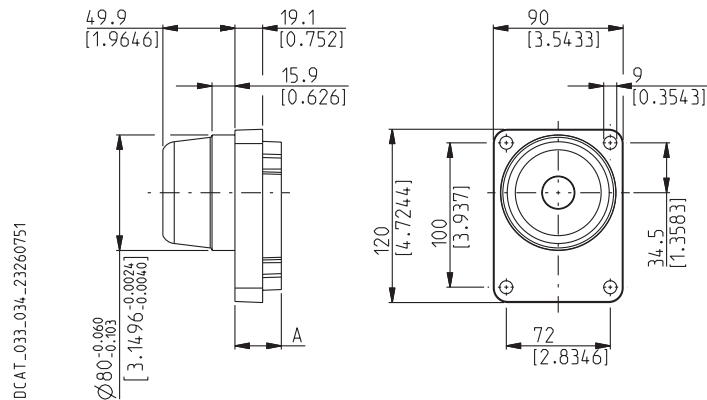

DRIVE SHAFTS

See page 52 ÷ 54

VERSIONS See page 46	A mm (in)	55
W8	32,1 (1.2638)	#

Standard combination
x Available combination

Replaces: 01/10.03

02/07.2006

POLARIS 30

MOUNTING FLANGES AND TABLE OF COMPATIBILITY

EUROPEAN

E3

Material: cast iron

D033-199/0706

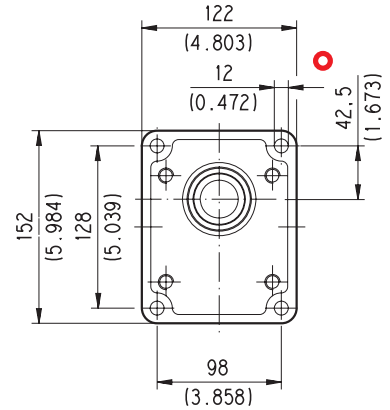
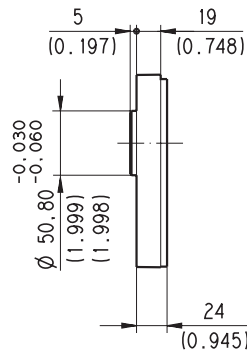

DRIVE SHAFTS

See page 55 e 56

VERSIONS See page 46	83	41	04	05	32	33	A5	A8
0	#	#	x	x	x	x	x	x

Standard combination
 x Available combination

EUROPEAN

E4

Material: cast iron

D033-200/0703

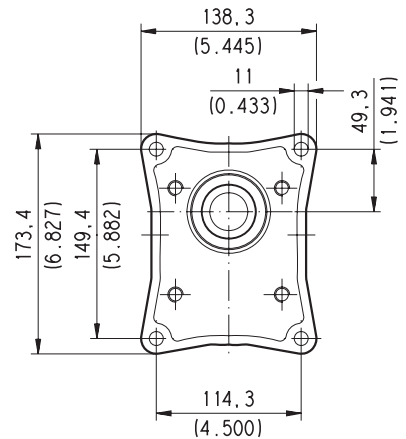
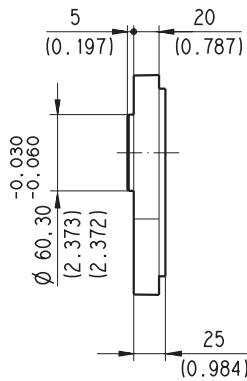

DRIVE SHAFTS

See page 55 e 56

VERSIONS See page 46	84	41	A5	A8
0	#	x	x	x

Standard combination
 x Available combination

Replaces: 01/10.03

02/07.2006

POLARIS 30

MOUNTING FLANGES AND TABLE OF COMPATIBILITY

GERMAN

B3

Material: cast iron

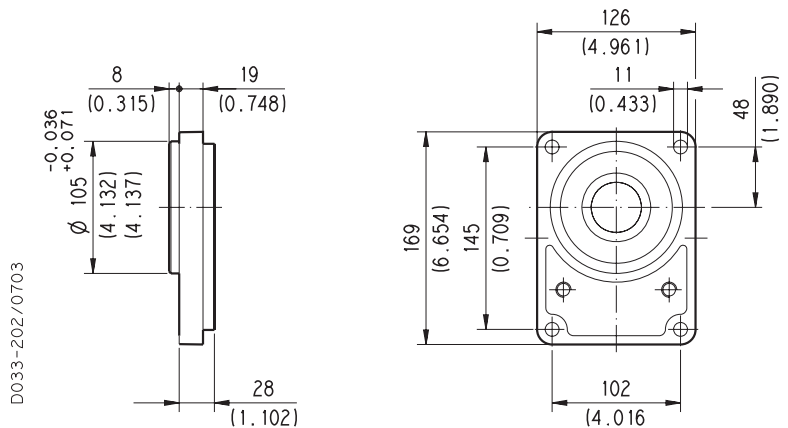

DRIVE SHAFTS

See page 55 e 56

VERSIONS See page 46	56	83	A5	A8
0	#	x	x	x

Standard combination
x Available combination

SAE "B" 2 BOLTS

S5

Material: cast iron

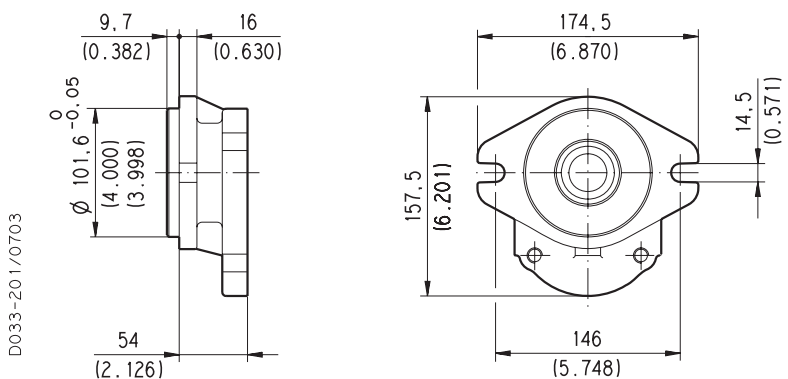

DRIVE SHAFTS

See page 55 e 56

VERSIONS See page 46	04	05	32	33
0	#	#	#	#

Standard combination
x Available combination

Replaces: 01/10.03

02/07.2006

POLARIS 30

MOUNTING FLANGES AND TABLE OF COMPATIBILITY

SAE "B" 2 BOLTS

U3

Material: cast iron



D033-203/0703

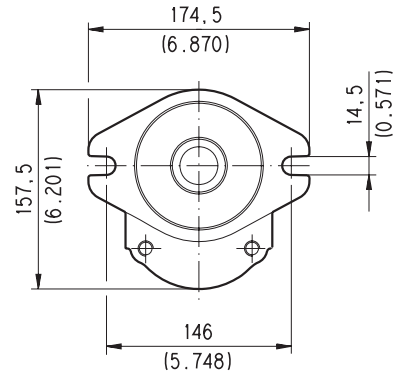
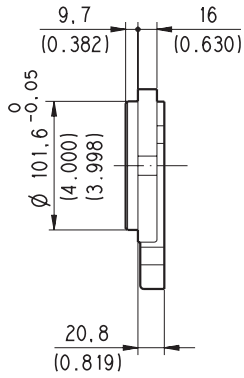

DRIVE SHAFTS
See page 55 e 56

VERSIONS See page 46	A5	A8	83
0	#	#	x

Standard combination
x Available combination

Replaces: 01/10.03

02/07.2006

IN/OUT PORTS TYPE

PORTS TYPE	SIDE PORTS												REAR PORTS				
	German		European		Split SSM		Split SSS		Gas BSPP		SAE ODT		Gas BSPP		SAE ODT		
Pump type	IN	OUT	IN	OUT	IN	OUT	IN	OUT	IN	OUT	IN	OUT	IN	OUT	IN	OUT	
Motor type	OUT	IN	OUT	IN	OUT	IN	OUT	IN	OUT	IN	OUT	IN	OUT	IN	OUT	IN	
PL. 10•1	BB	BA								GC	GC	OB	OA	GC	GC	OB	OA
PL. 10•1,5	BB	BA								GC	GC	OB	OA	GC	GC	OB	OA
PL. 10•2	BB	BA								GC	GC	OB	OA	GC	GC	OB	OA
PL. 10•2,5	BB	BA								GC	GC	OB	OA	GC	GC	OB	OA
PL. 10•3,15	BB	BA								GC	GC	OB	OA	GC	GC	OB	OA
PL. 10•4	BB	BA								GC	GC	OB	OA	GC	GC	OB	OA
PL. 10•5	BB	BA								GD	GD	OB	OA	GD	GD	OB	OA
PL. 10•5,8	BB	BA								GD	GD	OB	OA	GD	GD	OB	OA
PL. 10•6,3	BB	BA								GD	GD	OB	OA	GD	GD	OB	OA
PL. 10•8	BB	BA								GD	GD	OC	OB	GD	GD	OB	OB
PL. 10•10	BB	BA								GD	GD	OC	OB	GD	GD	OB	OB
PL. 20•4	BE	BC	EA	EA	MA	MA	SA	SA	GD	GD	OC	OC	GD	GD	OC	OC	
PL. 20•6,3	BE	BC	EA	EA	MA	MA	SA	SA	GD	GD	OC	OC	GD	GD	OC	OC	
PL. 20•7,2	BE	BC	EA	EA	MA	MA	SA	SA	GD	GD	OC	OC	GD	GD	OC	OC	
PL. 20•8	BE	BC	EA	EA	MA	MA	SA	SA	GD	GD	OC	OC	GD	GD	OC	OC	
PL. 20•9	BE	BC	EA	EA	MA	MA	SA	SA	GD	GD	OC	OC	GD	GD	OC	OC	
PL. 20•10,5	BE	BC	EA	EA	MA	MA	SA	SA	GD	GD	OC	OC	GD	GD	OC	OC	
PL. 20•11,2	BE	BC	EA	EA	MA	MA	SA	SA	GD	GD	OC	OC	GD	GD	OC	OC	
PL. 20•14	BE	BC	EB	EA	MB	MA	SB	SA	GE	GD	OD	OC	GE	GD	OD	OC	
PL. 20•16	BE	BC	EB	EA	MB	MA	SB	SA	GE	GD	OD	OC	GE	GD	OD	OC	
PL. 20•19	BE	BC	EB	EA	MB	MA	SB	SA	GE	GD	OD	OC	GE	GD	OD	OC	
PL. 20•20	BE	BC	EB	EA	MB	MA	SB	SA	GE	GD	OD	OC	GE	GD	OD	OC	
PL. 20•24,5	BE	BC	EB	EA	MC	MB	SC	SB	GE	GD	OD	OC	GE	GD	OD	OC	
PL. 20•25	BE	BC	EB	EA	MC	MB	SC	SB	GE	GD	OD	OC	GE	GD	OD	OC	
PL. 20•27,8	BE	BC	EB	EA	MC	MB	SC	SB	GE	GD	OD	OC	GE	GD	OD	OC	
PL. 20•31,5	BE	BC	EB	EA	MC	MB	SC	SB	GE	GD	OD	OC	GE	GD	OD	OC	
PL. 30•22	BM	BL	ED	EB	MB	MA	SB	SA	GF	GF	OF	OD					
PL. 30•27	BM	BL	ED	EB	MC	MB	SC	SB	GF	GF	OF	OD					
PL. 30•34	BM	BL	ED	EB	MC	MB	SC	SB	GF	GF	OF	OD					
PL. 30•38	BM	BL	ED	EB	MD	MC	SD	SC	GF	GF	OG	OF					
PL. 30•43	BM	BL	ED	EB	MD	MC	SD	SC	GF	GF	OG	OF					
PL. 30•46	BM	BL	ED	EB	MD	MC	SD	SC	GF	GF	OG	OF					
PL. 30•51	BM	BL	ED	EB	MD	MC	SD	SC	GF	GF	OG	OF					
PL. 30•61	BM	BL	ED	EB	ME	MD	SE	SD	GG	GF	OH	OG					
PL. 30•73	BM	BL	EF	ED	ME	MD	SE	SD	GG	GF	OH	OG					
PL. 30•82	BM	BL	EF	ED	ME	MD	SE	SD	GH	GG	OH	OG					
PL. 30•90	BM	BL	EF	ED	MF	ME	SF	SE	GH	GG	OH	OG					

01/10.03

EXTERNAL DRAIN PORTS

IN/OUT PORTS TYPE	SIDE PORTS						REAR PORTS	
	German	European	Split SSM	Split SSS	Gas BSPP	SAE ODT	Gas BSPP	SAE ODT
PL. 10	GA	-	-	-	GA	03	GA	03
PL. 20	TA	GB	GB	03	GB	03	GB	03
PL. 30	GC	GC	GC	OA	GC	OA	-	-

DRAIN PORTS SIZES

 Tightening torque for low pressure side port.

GAS STRAIGHT THREAD PORTS							BSPP
British standard pipe parallel (55°) conforms to UNI - ISO 228							
CODE	Nominal size	A	∅ B	∅ C	D	E	 Nm (lbf in)
			mm (in)	mm (in)	mm (in)	mm (in)	
GA	1/8"	G 1/8	16,5 (0.6496)	8,75 (0.3444)	12 (0.4724)	1 (0.0394)	5 ^{+0,25} (44 ÷ 46)
GB	1/4"	G 1/4	21,5 (0.8465)	12 (0.4724)	15 (0.5906)	1,5 (0.0591)	15 ⁺¹ (133 ÷ 142)

DCAT_006_026_21064779

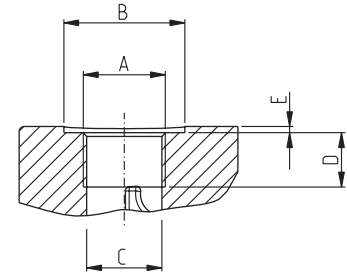

METRIC STRAIGHT THREAD PORTS ISO 6149							METRIC
Metric thread ISO 60° conforms to ISO/R 262							
CODE	A	∅ B	∅ C	D	E	 Nm (lbf in)	
		mm (in)	mm (in)	mm (in)	mm (in)		
TA	M 10x1	22 (0.8661)	9 (0.3543)	13 (0.5118)	0,5 (0.0197)	10 ^{+0,5} (89 ÷ 93)	

DCAT_006_027_21060524

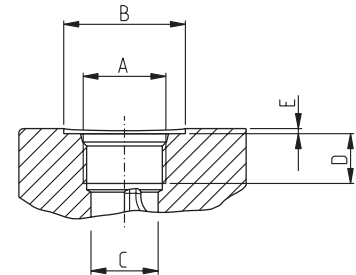



SAE STRAIGHT THREAD PORTS J514							ODT
American straight thread UNC-UNF 60° conforms to ANSI B 1.1							
CODE	A	∅ B	∅ C	D	E	 Nm (lbf in)	
		mm (in)	mm (in)	mm (in)	mm (in)		
03	7/16"-20 UNF-2B	21 (0.8267)	9,5 (0.3740)	14 (0.5512)	1 (0.0394)	12 ⁺¹ (106 ÷ 115)	

01/10.03

Other drain ports are shown on subsequent pages.

PORTS SIZES

 Tightening torque for low pressure side port.



 Tightening torque for high pressure side port [values obtained at 5075 psi (350 bar)]

For reversible rotation, please consult only the tightening torque for high pressure side port.

GERMAN FLANGED PORTS - 4 Bolts

GERMAN

Metric thread ISO 60° conforms to ISO/R 262

CODE	A	B	C		
	mm (in)	mm (in)	Thread Depth mm (in)	Nm (lbf in)	Nm (lbf in)
BA	8 (0.3150)	30 (1.1811)	M6 12 (0.4724)	8 ^{+0,5} (71 ÷ 75)	8 ^{+0,5} (71 ÷ 75)
BB	13 (0.5118)	30 (1.1811)	M6 12 (0.4724)	8 ^{+0,5} (71 ÷ 75)	8 ^{+0,5} (71 ÷ 75)
BC	15 (0.5906)	35 (1.3780)	M 6 12 (0.4724)	8 ^{+0,5} (71 ÷ 75)	8 ^{+0,5} (71 ÷ 75)
BE	20 (0.7874)	40 (1.5748)	M 6 12 (0.4724)	15 ⁺¹ (133 ÷ 142)	15 ⁺¹ (133 ÷ 142)
BL	19 (0.7480)	55 (2.1654)	M8 18 (0.7087)	20 ⁺¹ (177 ÷ 186)	20 ⁺¹ (177 ÷ 186)
BM	27 (1.0630)	55 (2.1654)	M8 18 (0.7087)	15 ⁺¹ (133 ÷ 142)	20 ⁺¹ (177 ÷ 186)

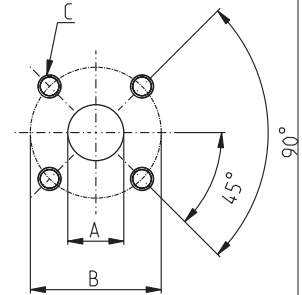

DCAT_033_028_17681888



EUROPEAN FLANGED PORTS - 4 Bolts

EUROPEAN

Metric thread ISO 60° conforms to ISO/R 262

CODE	A	B	C		
	mm (in)	mm (in)	Thread Depth mm (in)	Nm (lbf in)	Nm (lbf in)
EA	13 (0.5118)	30 (1.1811)	M 6 13 (0.5118)	8 ^{+0,5} (71 ÷ 75)	8 ^{+0,5} (71 ÷ 75)
EB	19 (0.7480)	40 (1.5748)	M 8 14 (0.5512)	15 ⁺¹ (133 ÷ 142)	15 ⁺¹ (133 ÷ 142)
			M 8 (◆) 18 (0.7087)	15 ⁺¹ (◆) (133 ÷ 142)	15 ⁺¹ (◆) (133 ÷ 142)
ED	27 (1.0630)	51 (2.0079)	M 10 18 (0.7087)	20 ⁺¹ (177 ÷ 186)	30 ^{+2,5} (266 ÷ 288)
EF	33 (1.2992)	62 (2.4409)	M 12 18 (0.7087)	25 ⁺¹ (221 ÷ 230)	50 ^{+2,5} (443 ÷ 465)

DCAT_006_024_21060533

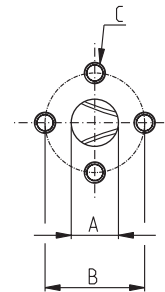

(◆) For POLARIS 30

01/10.03

PORTS SIZES

 Tightening torque for low pressure side port.



 Tightening torque for high pressure side port [values obtained at 5075 psi (350 bar)]

For reversible rotation, please consult only the tightening torque for high pressure side port.

SAE FLANGED PORTS J518 - Standard pressure series 3000 PSI

SSM

Metric thread ISO 60° conforms to ISO/R 262

CODE	A	B	C	D		
	mm (in)	mm (in)	mm (in)	Thread Depth mm (in)	Nm (lbf in)	Nm (lbf in)
MA	12,5 (0.4921)	38,1 (1.50)	17,5 (0.6890)	M 8	15 ⁺¹	15 ⁺¹
				14 (0.5512)	(133 ÷ 142)	(133 ÷ 142)
				M8 (◆)	20 ⁺¹ (◆)	20 ⁺¹ (◆)
MB	19 (0.7480)	47,6 (1.8740)	22,2 (0.8740)	M 10	20 ⁺¹	25 ⁺¹
				14 (0.5512)	(177 ÷ 186)	(266 ÷ 288)
				M 10 (◆)	20 ⁺¹ (◆)	35 ^{+2,5} (◆)
MC	25,4 (1.0000)	52,4 (2.0630)	26,2 (1.0315)	M 10	20 ⁺¹	25 ⁺¹
				14 (0.5512)	(177 ÷ 186)	(266 ÷ 288)
				M 10 (◆)	20 ⁺¹ (◆)	35 ^{+2,5} (◆)
MD	30,5 (1.2008)	58,7 (2.3110)	30,2 (1.1890)	M 10	20 ⁺¹	30 ^{+2,5}
				15 (0.5906)	(177 ÷ 186)	(266 ÷ 288)
				M 10 (◆)	20 ⁺¹ (◆)	35 ^{+2,5} (◆)
ME	39,3 (1.5472)	69,8 (2.7480)	35,7 (1.4055)	M 12	30 ^{+2,5}	60 ⁺⁵
				22 (0.8661)	(266 ÷ 288)	(531 ÷ 575)
MF	51 (2.0079)	77,8 (3.0630)	42,9 (1.6890)	M 12	30 ^{+2,5}	60 ⁺⁵
				22 (0.8661)	(266 ÷ 288)	(531 ÷ 575)

DCAT_006_025_21064252

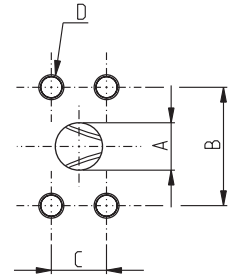



(◆) For POLARIS 30

SAE FLANGED PORTS J518 - Standard pressure series 3000 PSI

SSS

American straight thread UNC-UNF 60° conforms to ANSI B 1.1

CODE	A	B	C	D		
	mm (in)	mm (in)	mm (in)	Thread Depth mm (in)	Nm (lbf in)	Nm (lbf in)
SA	12,5 (0.4921)	38,1 (1.50)	17,5 (0.6890)	5/16-18 UNC-2B	15 ⁺¹	15 ⁺¹
				14 (0.5512)	(133 ÷ 142)	(133 ÷ 142)
				5/16-18 UNC-2B (◆)	20 ⁺¹ (◆)	20 ⁺¹ (◆)
SB	19 (0.7480)	47,6 (1.8740)	22,2 (0.8740)	3/8 - 16 UNC-2B	20 ⁺¹	20 ⁺¹
				14 (0.5512)	(177 ÷ 186)	(177 ÷ 186)
				3/8 - 16 UNC-2B (◆)	30 ^{+2,5} (◆)	20 ⁺¹ (◆)
SC	25,4 (1.0000)	52,4 (2.0630)	26,2 (1.0315)	3/8 - 16 UNC-2B	20 ⁺¹	25 ⁺¹
				14 (0.5512)	(177 ÷ 186)	(221 ÷ 230)
				3/8 - 16 UNC-2B (◆)	20 ⁺¹ (◆)	30 ^{+2,5} (◆)
SD	30,5 (1.2008)	58,7 (2.3110)	30,2 (1.1890)	7/16 - 14 UNC-2B	20 ⁺¹	45 ^{+2,5}
				22 (0.8661)	(177 ÷ 186)	(398 ÷ 420)
SE	39,3 (1.5472)	69,8 (2.7480)	35,7 (1.4055)	1/2 - 13 UNC-2B	30 ^{+2,5}	70 ⁺⁵
				22 (0.8661)	(266 ÷ 288)	(620 ÷ 664)
SF	51 (2.0079)	77,8 (3.0630)	42,9 (1.6890)	1/2 - 13 UNC-2B	30 ^{+2,5} (◆)	70 ⁺⁵
				22 (0.8661)	(266 ÷ 288)	(620 ÷ 664)

DCAT_006_028_21060740

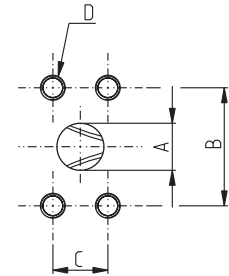

(◆) For POLARIS 30

01/10.03

PORTS SIZES

 Tightening torque for low pressure side port.

 Tightening torque for high pressure side port [values obtained at 5075 psi (350 bar)]

For reversible rotation, please consult only the tightening torque for high pressure side port.



GAS STRAIGHT THREAD PORTS

BSPP

British standard pipe parallel (55°) conforms to UNI - ISO 228

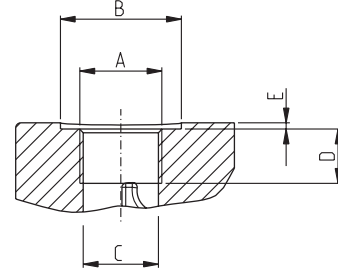
DLAT_006_026_21064779



CODE	Nominal size	A	Ø B	Ø C	D	E		
			mm (in)	mm (in)	mm (in)	mm (in)	Nm (lbf in)	Nm (lbf in)
GC	3/8"	G 3/8	30 (#) (1.1811)	15 (0.5906)	10 (#) (0.3937)	2 (#) (0.0787)	15 ⁺¹ (#) (133 ÷ 142)	-
			-		14 (0.5512)	-	15 ⁺¹ (133 ÷ 142)	25 ⁺¹ (221 ÷ 230)
GD	1/2"	G 1/2	-	19 (0.7480)	14 (0.5512)	-	20 ⁺¹ (177 ÷ 186)	50 ^{+2,5} (443 ÷ 465)
					17 (◆) (0.6693)			
GE	3/4"	G 3/4	-	24,5 (0.9646)	18 (0.7087)	-	30 ^{+2,5} (266 ÷ 288)	90 ⁺⁵ (797 ÷ 841)
GF	1"	G 1	-	30,5 (1.2008)	18 (0.7086)	-	50 ^{+2,5} (443 ÷ 465)	130 ⁺¹⁰ (1151 ÷ 1239)
GG	1" 1/4	G 1 1/4	-	39 (1.5354)	22 (0.8661)	-	60 ⁺⁵ (531 ÷ 575)	170 ⁺¹⁰ (1505 ÷ 1593)
GH	1" 1/2	G 1 1/2	-	45 (1.7716)	24 (0.9448)	-	70 ⁺⁵ (620 ÷ 664)	210 ⁺¹⁵ (1859 ÷ 1992)

(#) Drain port

(◆) For POLARIS 20

Replaces: 01/10.03

02/07.2006

PORTS SIZES

 Tightening torque for low pressure side port.

 Tightening torque for high pressure side port [values obtained at 5075 psi (350 bar)]



For reversible rotation, please consult only the tightening torque for high pressure side port.

SAE STRAIGHT THREAD PORTS J514

ODT

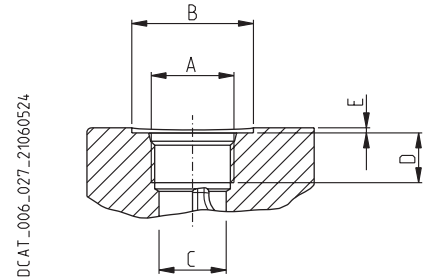
American straight thread UNC-UNF 60° conforms to ANSI B 1.1



CODE	Nominal size	A	∅ B	∅ C	D	E		
			mm (in)	mm (in)	mm (in)	mm (in)	Nm (lbf in)	Nm (lbf in)
OA	3/8"	9/16" - 18 UNF - 2B	26 (1.0236)	13 (0.5118)	15 (0.5906)	1 (0.03934)	15 ⁺¹ (133 ÷ 142)	25 ⁺¹ (221 ÷ 230)
						2 (#) (0.0787)	15 ⁺¹ (#) (133 ÷ 142)	-
OB	1/2"	3/4" - 16 UNF - 2B	32 (1.2598)	17,5 (0.690)	15 (0.5906)	-	20 ⁺¹ (177 ÷ 186)	45 ^{+2,5} (398 ÷ 420)
OC	5/8"	7/8" - 14 UNF - 2B	35 (1.3780)	20,5 (0.8071)	15 (◆) (0.5906)	0,5 (0.0197)	30 ^{+2,5} (266 ÷ 288)	70 ⁺⁵ (620 ÷ 664)
					17 (0.6693)			
OD	3/4"	1 1/16" - 12 UNF - 2B	42 (1.6535)	24,8 (0.9764)	20 (0.7874)	0,5 (0.0197)	40 ^{+2,5} (354 ÷ 376)	120 ⁺¹⁰ (1062 ÷ 1151)
OF	1"	1 5/16" - 12 UNF - 2B	49 (1.9291)	30,5 (1.2008)	20 (0.7874)	0,5 (0.0197)	60 ⁺⁵ (531 ÷ 575)	170 ⁺¹⁰ (1505 ÷ 1593)
OG	1" 1/4	1 5/8" - 12 UNF - 2B	58 (2.2835)	39,1 (1.5394)	20 (0.7874)	0,5 (0.0197)	70 ⁺⁵ (620 ÷ 664)	200 ⁺¹⁰ (1770 ÷ 1858)
OH	1" 1/2	1 7/8" - 12 UNF - 2B	65 (2.5591)	45 (1.7717)	20 (0.7874)	0,5 (0.0197)	100 ⁺⁵ (885 ÷ 929)	270 ⁺¹⁵ (2389 ÷ 2522)

(#) Drain port
 (◆) For POLARIS 10

01/10.03

CHANGING ROTATION

Example of changing rotation: from PLP20 pump clockwise to counterclockwise

To change rotation of Polaris unidirectional pumps and motors it is necessary to operate in the following way:

- 1 - Clean the pump externally with care.
- 2 - Loosen, and remove, the clamp bolts (1).
- 3 - Coat the sharp edges of the drive shaft (4) with adhesive tape and smear a layer of clean grease on the shaft end extension to avoid damaging the lip of the shaft seal when removing the mounting flange.
- 4 - Remove the mounting flange (2), taking care to keep the flange as straight as possible during removal. If the flange is stuck, tap around the edge with a fibre or rubber mallet in order to break away from the body. Ensure that while removing the front mounting flange, the drive shaft and other components remain in position.
- 5 - Ease the drive gear (4) up to facilitate removal the front plate (3), taking care that the precision ground surfaces do not become damaged, and remove the drive gear.
- 6 - Remove the driven gear (5) without overturning. The rear plate has not to be removed.

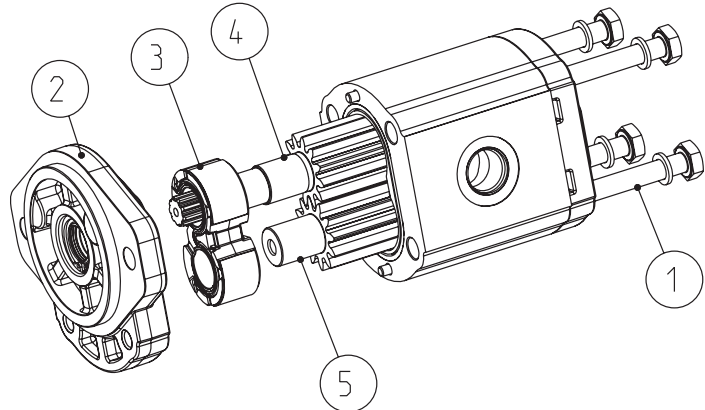

DCA7_033_040

- 7 - Re-locate the driven gear (5) in the position previously occupied by the drive gear (4)
- 8 - Re-locate the drive gear (4) in the position previously occupied by the driven gear (5).
- 9 - Replace the front plate (3) in its original position.

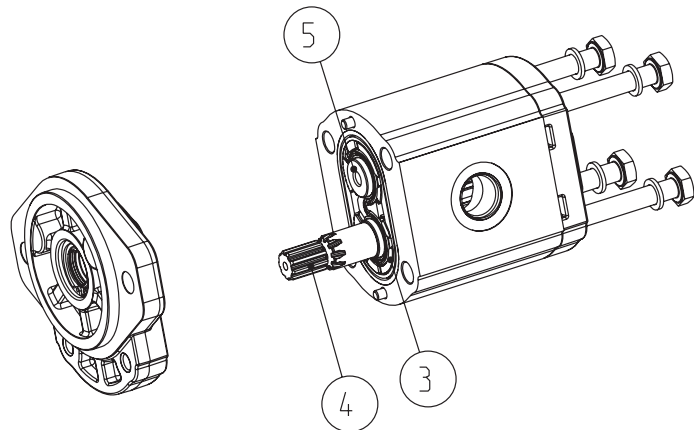

DCA7_033_029

- 10 - Gently wipe the machined surface of the mounting flange (2) and the body with a flat hand stone.
- 11 - Refit the front mounting flange (2) turned 180° from its original position.
- 12 - Refit the clamp bolts (1) with the washers and tighten in a crisscross pattern with the following torque value:
70⁺⁵ Nm (620 ÷ 664 lbf in) with cast iron cover.
45⁺⁵ Nm (398 ÷ 443 lbf in) with one or both cover in aluminium.
- 13 - Check that the pump rotates freely when the drive shaft (4) is turned by hand. If not a pressure plate seal may be pinched.
- 14 - The pump is ready for installation with the original rotation reversed.

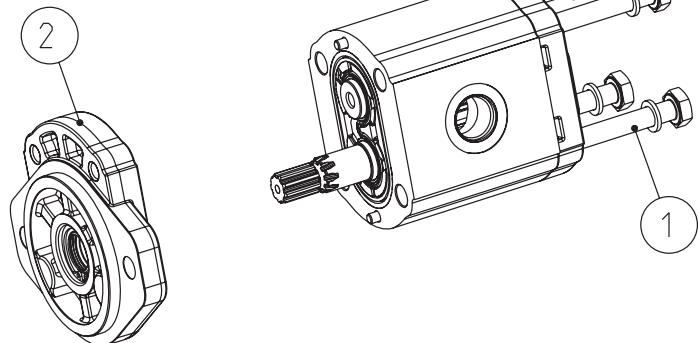

DCA7_033_011

01/10.03

INSTRUCTIONS

INSTALLATION

Pump

The direction of rotation of single-rotation pumps must be the same as that of the drive shaft. Check that the coupling flange correctly aligns the transmission shaft and the pump shaft. Flexible couplings should be used (never rigid fittings) which will not generate an axial or radial load on the pump shaft.

Motor

The direction of rotation of single-rotation motors must match circuit connections. Check that the coupling flange correctly aligns the transmission shaft and the motor shaft. Flexible couplings should be used (never rigid fittings) which will not generate an axial or radial load on the motor shaft.

TANK

Tank capacity must be sufficient for the system's operating conditions (~ 3 times the amount of oil in circulation) to avoid overheating of the fluid. A heat exchanger should be installed if necessary. The intake and return lines in the tank must be spaced apart (by inserting a vertical divider) to prevent the return-line oil from being taken up again immediately.

LINES

The lines must have a major diameter which is at least as large as the diameter of pump or motor ports, and must be perfectly sealed. To reduce loss of power, the lines should be as short as possible, reducing the sources of hydraulic resistance (elbow, throttling, gate valves, etc.) to a minimum. A length of flexible tubing is recommended to reduce the transmission of vibrations. All return lines must end below the minimum oil level, to prevent foaming. Before connecting the lines, remove any plugs and make sure that the lines are perfectly clean.

FILTERS

We recommend filtering the entire system flow. Filters on suction and return line must be fitted in according to the contamination class as indicated in the first pages of the catalogue. Casappa recommends to use its own production filters:



HYDRAULIC FLUID

Use hydraulic fluid conforming to ISO/DIN standards, having viscosity as specified in the first pages of the catalogue. Avoid using mixtures of different oils which could result in decomposition and reduction of the oil's lubricating power.

STARTING UP

Check that all circuit connections are tight and that the entire system is completely clean. Insert the oil in the tank, using a filter. Bleed the circuit to assist in filling. Set the pressure relief valves to the lowest possible setting. Turn on the system for a few moments at minimum speed, then bleed the circuit again and check the level of oil in the tank. In the difference between pump or motor temperature and fluid temperature exceeds 50 °F (10 °C), rapidly switch the system on and off to heat it up gradually. Then gradually increase the pressure and speed of rotation until the pre-set operating levels as specified in the catalogue are attained.

PERIODICAL CHECKS - MAINTENANCE

Keep the outside surface clean especially in the area of the drive shaft seal. In fact, abrasive powder can accelerate wear on the seal and cause leakage. Replace filters regularly to keep the fluid clean. The oil level must be checked and oil replaced periodically depending on the system's operating conditions.

Replaces: 01/10.03

02/07.2006

VALVE OPTIONS (◆)

PRIORITY VALVE			MAX PRESSURE RELIEF VALVE		
P1	Costant delivery and internal recirculation of excess flow.		VPEF..	Fixed setting with external drain.	
P2	Costant delivery at controlled pressure. Internal recirculation of excess flow and drain valve.		VPIF..	Fixed setting with internal drain.	
P3	Costant delivery at controlled pressure. Excess flow and drain valve must be connected to tank.		VPER..	Adjustable setting with external drain.	
P4	Costant delivery and excess flow can both be used under load.		VPIR..	Adjustable setting with internal drain.	
ELECTRIC VALVE FOR MOTORS			LOAD SENSING VALVE		
P5T	Costant delivery at controlled pressure with drain valve connected to tank. Excess flow can be used under load.		...	Static.	
P7	Costant delivery. Excess flow at controlled pressure can be used under load. Internal recirculation of drain valve.		...	Dynamic.	
P9	Costant delivery at controlled pressure. Internal recirculation of valve drain. Excess flow can be used under load.		...	Dynamic with relief valve fitted on the main line.	
EC08..	By-pass valve normally closed with max. pressure relief valve and anti-cavitation valve.		...	Dynamic with relief valve fitted on controlled line.	
DBVSA..	Proportional relief valve and anti-cavitation valve.		CHECK VALVE		
V8	Anti-cavitation valve.				

01/10.03

(◆) For more information please consult our technical sales department.

HOW TO ORDER POLARIS 10 SINGLE UNITS

1 2 3 4 5 6 7 8 9 10 11 12 13

PLP10•1 - L 0 81 E1 - L - BB/BA - N EL C L - GA - FS

Replaces: 01/10.03

1	Type	PUMP TYPE	MOTOR TYPE
	in ³ /rev (cm ³ /rev)		
0.07 (1,07)		PLP 10•1	PLM 10•1
0.10 (1,60)		PLP 10•1,5	PLM 10•1,5
0.13 (2,13)		PLP 10•2	PLM 10•2
0.16 (2,67)		PLP 10•2,5	PLM 10•2,5
0.20 (3,34)		PLP 10•3,15	PLM 10•3,15
0.26 (4,27)		PLP 10•4	PLM 10•4
0.33 (5,34)		PLP 10•5	PLM 10•5
0.38 (6,20)		PLP 10•5,8	PLM 10•5,8
0.41 (6,67)		PLP 10•6,3	PLM 10•6,3
0.52 (8,51)		PLP 10•8	PLM 10•8
0.65 (10,67)		PLP 10•10	PLM 10•10

2	Rotation	CODE
Left		S
Right		D
Reversible rear external drain		R
Reversible side external drain		L
Reversible internal drain		B

3	Version	CODE
Without outboard bearing		0

4	Drive shaft	CODE
European tapered 1:8		81
European tapered 1:8		86
SAE "AA" spline (9 teeth)		02
SAE "AA" straight		30
SAE straight		36
Straight		29

5	Mounting flange	CODE
European		E1
European		E7
European		E8
German 2 bolt		B1
German 4 bolt		K2
SAE "AA" 2 bolt		S0
SAE "AA" 2-4 bolt		R9
SAE 2-4 bolt		R8
SAE 2 bolt		W9

6	Ports position	CODE
Side		L
Rear		P

02/07.2006

CODE	Ports IN/OUT			7
GERMAN FLANGED PORTS				
Side	Rear	Type		
BB/BA		PLP 10	1-1,5-2-2,5-3,15	
BA/BB		PLM 10	4-5-5,8-6,3-8-10	
GAS STRAIGHT THREAD PORTS (BSPP)				
Side	Rear	Type		
GC/GC	GC/GC	PLP 10	1-1,5-2-2,5-3,15-4	
		PLM 10		
GD/GD	GD/GD	PLP 10	5-5,8-6,3-8-10	
		PLM 10		
SAE STRAIGHT THREAD PORTS (ODT)				
Side	Rear	Type		
OB/OA	OB/OA	PLP 10	1-1,5-2-2,5-3,15-4	
OA/OB	OA/OB	PLM 10	5-5,8-6,3	
OC/OB	OB/OB	PLP 10	8-10	
OB/OC	OB/OB	PLM 10		

CODE	Seals (a)	8
N	Buna (standard)	
V	Viton	

CODE	Cover options (b)	9
	Cast iron mounting flange and rear cover (standard - no code)	
E	Aluminium mounting flange and cast iron rear cover	
L	Cast iron mounting flange and aluminium rear cover	
EL	Aluminium mounting flange and rear cover	

CODE	Shaft seal options	10
C	High back pressure seal with wiper seal	
D	Standard seal with wiper seal	
H	High back pressure seal	

CODE	Drain port position - Rev. rotation L	11
L	Side drain with side port position	
*	Side drain with bottom port position	

CODE	Drain port			12
IN/OUT GERMAN FLANGED PORTS				
Side	Rear	Type		
GA		PLP 10	1-1,5-2-2,5-3,15	
		PLM 10	4-5-5,8-6,3-8-10	
IN/OUT GAS STRAIGHT THREAD PORTS (BSPP)				
Side	Rear	Type		
GA	GA	PLP 10	1-1,5-2-2,5-3,15	
		PLM 10	4-5-5,8-6,3-8-10	
IN/OUT SAE STRAIGHT THREAD PORTS (ODT)				
Side	Rear	Type		
03	03	PLP 10	1-1,5-2-2,5-3,15	
		PLM 10	4-5-5,8-6,3-8-10	

CODE	Shaft arrangement	13
FS	Female spline	

(a) Choose the seals according to the temperature shown on page 3.

(b) Mounting flange material on page 57 ÷ 59
Rear cover material on page 31 ÷ 32

HOW TO ORDER POLARIS 20 SINGLE UNITS

1
2
3
4
5
6
7
8
9
10
11
12
13

PLP20•4 - L 0 82 E2 - L - EA/EA - N EL C * - GB - FS

1	Type	PUMP TYPE	MOTOR TYPE
	in ³ /rev (cm ³ /rev)		
0.30 (4,95)		PLP 20•4	PLM 20•4
0.40 (6,61)		PLP 20•6,3	PLM 20•6,3
0.44 (7,29)		PLP 20•7,2	PLM 20•7,2
0.50 (8,26)		PLP 20•8	PLM 20•8
0.56 (9,17)		PLP 20•9	PLM 20•9
0.66 (10,9)		PLP 20•10,5	PLM 20•10,5
0.69 (11,23)		PLP 20•11,2	PLM 20•11,2
0.89 (14,53)		PLP 20•14	PLM 20•14
1.03 (16,85)		PLP 20•16	PLM 20•16
1.16 (19,09)		PLP 20•19	PLM 20•19
1.29 (21,14)		PLP 20•20	PLM 20•20
1.52 (24,84)		PLP 20•24,5	PLM 20•24,5
1.61 (26,42)		PLP 20•25	PLM 20•25
1.72 (28,21)		PLP 20•27,8	PLM 20•27,8
2.01 (33,03)		PLP 20•31,5	PLM 20•31,5

2	Rotation	CODE
Left		S
Right		D
Reversible rear external drain		R
Reversible side external drain		L
Reversible internal drain		B

3	Version	CODE
Without outboard bearing		0
With outboard bearing		W8
With outboard bearing		4
With outboard bearing		5
With outboard bearing		6
With outboard bearing		7
With outboard bearing		8
With outboard bearing		9

4	Drive shaft	CODE
European tapered 1:8		82
German tapered 1:5		54
German tapered 1:5		55
Straight		46
SAE "A" spline (9 teeth)		03
SAE spline (10 teeth)		01
SAE "A" spline (11 teeth)		07
SAE "A" straight		31
Straight		49
Straight		50
SAE "B" spline		04
SAE "B" straight		32
DIN 54 82 spline		12
Straight (only for version 6)		48
Straight (only for version 8)		B1
Tang		95

CODE	Mounting flange	5
E2	European	
B2	German	
B4	German 2 bolt	
B5	German 2 bolt	
B6	German 4 bolt	
S1	SAE "A" 2 bolt	
S2	SAE "A" 2 bolt	
S9	SAE "A" 2 bolt	
S5	SAE "B" 2 bolt	
W8	German	

CODE	Ports position	6
L	Side	
P	Rear	

CODE	Ports IN/OUT		7
GERMAN FLANGED PORTS			
Side	Rear	Type	
BE/BC		PLP 20	4-6,3-7,2-8-9-10,5-11,2 14-16-19-20-24,5-25 27,8-31,5
BC/BE		PLM 20	
EUROPEAN FLANGED PORTS			
Side	Rear	Type	
EA/EA		PLP 20	4-6,3-7,2-8-9-10,5-11,2
		PLM 20	
EB/EA		PLP 20	14-16-19-20-24,5-25 27,8-31,5
EA/EB		PLM 20	
SAE FLANGED PORTS (SSM)			
Side	Rear	Type	
MA/MA		PLP 20	4-6,3-7,2-8-9-10,5-11,2
		PLM 20	
MB/MA		PLP 20	14-16-19-20
MA/MB		PLM 20	
MC/MB		PLP 20	24,5-25-27,8-31,5
MB/MC		PLM 20	
SAE FLANGED PORTS (SSS)			
Side	Rear	Type	
SA/SA		PLP 20	4-6,3-7,2-8-9-10,5-11,2
		PLM 20	
SB/SA		PLP 20	14-16-19-20
SA/SB		PLM 20	
SC/SB		PLP 20	24,5-25-27,8-31,5
SB/SC		PLM 20	

01/10.03

HOW TO ORDER POLARIS 20 SINGLE UNITS

Replaces: 01/10.03

7 Ports IN/OUT				CODE
GAS STRAIGHT THREAD PORTS (BSPP)				
Type		Side		Rear
4-6,3-7,2-8-9-10,5-11,2	PLP 20	GD/GD	GD/GD	GD/GD
	PLM 20			
14-16-19-20-24,5-25 27,8-31,5	PLP 20	GE/GD	GE/GD	GE/GD
	PLM 20			
SAE STRAIGHT THREAD PORTS (ODT)				
Type		Side		Rear
4-6,3-7,2-8-9-10,5-11,2	PLP 20	OC/OC	OC/OC	OC/OC
	PLM 20			
14-16-19-20-24,5-25 27,8-31,5	PLP 20	OD/OC	OD/OC	OD/OC
	PLM 20			

8 Seals (a)		CODE
Buna (standard)		N
Viton		V

9 Cover options (b)		CODE
Cast iron mounting flange and rear cover (standard - no code)		
Aluminium mounting flange and cast iron rear cover		E
Cast iron mounting flange and aluminium rear cover		L
Aluminium mounting flange and rear cover		EL

10 Shaft seal options		CODE
High back pressure seal with wiper seal		C
Standard seal with wiper seal		D
High back pressure seal		H

CODE	Drain port position - Rev. rotation L	11
L	Side drain with side port position	
*	Side drain with bottom port position	

CODE	Drain port		12
IN/OUT GERMAN FLANGED PORTS			
Side	Rear	Type	
TA		PLP 20	4-6,3-7,2-8-9-10,5-11,2 24,5-25-27,8-31,5
		PLM 20	

IN/OUT EUROPEAN FLANGED PORTS			
Side	Rear	Type	
GB		PLP 20	4-6,3-7,2-8-9-10,5-11,2 24,5-25-27,8-31,5
		PLM 20	

IN/OUT SAE FLANGED PORTS (SSM)			
Side	Rear	Type	
GB		PLP 20	4-6,3-7,2-8-9-10,5-11,2 24,5-25-27,8-31,5
		PLM 20	

IN/OUT SAE FLANGED PORTS (SSS)			
Side	Rear	Type	
03		PLP 20	4-6,3-7,2-8-9-10,5-11,2 24,5-25-27,8-31,5
		PLM 20	

IN/OUT GAS STRAIGHT THREAD PORTS (BSPP)			
Side	Rear	Type	
GB	GB	PLP 20	4-6,3-7,2-8-9-10,5-11,2 24,5-25-27,8-31,5
		PLM 20	

IN/OUT SAE STRAIGHT THREAD PORTS (ODT)			
Side	Rear	Type	
03	03	PLP 20	4-6,3-7,2-8-9-10,5-11,2 24,5-25-27,8-31,5
		PLM 20	

CODE	Shaft arrangement	13
FS	Female spline	

- (a) Choose the seals according to the temperature shown on page 3.
- (b) Mounting flange material on page 60 ÷ 64
Rear cover material on page 33 ÷ 34

○ 02/07.2006

HOW TO ORDER POLARIS 30 SINGLE UNITS

1
2
3
4
5
6
7
8
9
10

PLP30-22 - R 0 83 E3 - L - ED/EB - N - C - FS

1	Type	PUMP TYPE	MOTOR TYPE
	in ³ /rev (cm ³ /rev)		
	1.34 (21,99)	PLP 30-22	PLM 30-22
	1.63 (26,70)	PLP 30-27	PLM 30-27
	2.11 (34,55)	PLP 30-34	PLM 30-34
	2.40 (39,27)	PLP 30-38	PLM 30-38
	2.68 (43,98)	PLP 30-43	PLM 30-43
	3.16 (51,83)	PLP 30-51	PLM 30-51
	3.74 (61,26)	PLP 30-61	PLM 30-61
	4.50 (73,82)	PLP 30-73	PLM 30-73
	4.98 (81,68)	PLP 30-82	PLM 30-82
	5.56 (91,10)	PLP 30-90	PLM 30-90

2	Rotation	CODE
	Left	S
	Right	D
	Reversible rear external drain	R

3	Version	CODE
	Without outboard bearing	0

4	Drive shaft	CODE
	European tapered 1:8	83
	European tapered 1:8	84
	German tapered 1:5	56
	Straight	41
	SAE "B" spline	A8
	SAE "BB" spline	A5
	SAE "B" spline	04
	SAE "BB" spline	05
	SAE "B" straight	32
	SAE "BB" straight	33

5	Mounting flange	CODE
	European	E3
	European	E4
	German	B3
	SAE "B" 2 bolt	S5
	SAE "B" 2 bolt	U3

6	Ports position	CODE
	Side	L

7	Ports IN/OUT		CODE
GERMAN FLANGED PORTS			
	Type	Side	
	22-27-34-38-43	PLP30	BM/BL
	46-51-61-73-82-90	PLM30	BL/BM
EUROPEAN FLANGED PORTS			
	Type	Side	
	22-27-34-38-43	PLP30	ED/EB
	46-51-61	PLM30	EB/ED
	73-82-90	PLP30	EF/ED
		PLM30	ED/EF

CODE	Ports IN/OUT		7
SAE FLANGED PORTS (SSM)			
	Side	Type	
MB/MA	PLP 30	22	
MA/MB	PLM 30		
MC/MB	PLP 30	27-34	
MB/MC	PLM 30		
MD/MC	PLP 30	38-43-46-51	
MC/MD	PLM 30		
ME/MD	PLP 30	61-73-82	
MD/ME	PLM 30		
MF/ME	PLP 30	90	
ME/MF	PLM 30		

SAE FLANGED PORTS (SSS)			
	Side	Type	
SB/SA	PLP 30	22	
SA/SB	PLM 30		
SC/SB	PLP 30	27-34	
SB/SC	PLM 30		
SD/SC	PLP 30	38-43-46-51	
SC/SB	PLM 30		
SE/SD	PLP 30	61-73-82	
SD/SE	PLM 30		
SF/SE	PLP 30	90	
SE/SF	PLM 30		

GAS STRAIGHT THREAD PORTS (BSPP)			
	Side	Type	
GF/GF	PLP 30	22-27-34-38-43-46-51	
	PLM 30		
GG/GF	PLP 30	61-73	
GF/GG	PLM 30		
GH/GG	PLP 30	82-90	
GG/GH	PLM 30		

SAE STRAIGHT THREAD PORTS (ODT)			
	Side	Type	
OF/OD	PLP 30	22-27-34	
OD/OF	PLM 30		
OG/OF	PLP 30	38-43-46-51	
OF/OG	PLM 30		
OH/OG	PLP 30	61-73-82-90	
OG/OH	PLM 30		

CODE	Seals (a)	8
N	Buna (standard)	
V	Viton	

CODE	Shaft seal options	9
C	High back pressure seal with wiper seal	
D	Standard seal with wiper seal	
H	High back pressure seal	

CODE	Shaft arrangement	10
FS	Female spline	

(a) Choose the seals according to the temperature shown on page 3.

01/10.03

HOW TO ORDER POLARIS 10 MULTIPLE PUMPS

1 2 3 4 5 6 7 8 9 10 11 12

PLP10•1 – 81 E1 – L BA/BA /
Front section

10•1 – L BA/BA /
Intermediate section

10•1 – L **/BA – V7 – S 0 N EL C FS
Rear section

Replaces: 01/10.03

1	Type	PUMP TYPE
	in ³ /rev (cm ³ /rev)	
0.07 (1,07)		PLP 10•1
0.10 (1,60)		PLP 10•1,5
0.13 (2,13)		PLP 10•2
0.16 (2,67)		PLP 10•2,5
0.20 (3,34)		PLP 10•3,15
0.26 (4,27)		PLP 10•4
0.33 (5,34)		PLP 10•5
0.38 (6,20)		PLP 10•5,8
0.41 (6,67)		PLP 10•6,3
0.52 (8,51)		PLP 10•8
0.65 (10,67)		PLP 10•10

2	Drive shaft	CODE
	European tapered 1:8	81
	European tapered 1:8	86
	SAE "AA" spline (9 teeth)	02
	SAE "AA" straight	30
	SAE straight	36
	Straight	29

3	Mounting flange	CODE
	European	E1
	European	E7
	European	E8
	German 2 bolt	B1
	German 4 bolt	K2
	SAE "AA" 2 bolt	S0
	SAE "AA" 2-4 bolt	R9
	SAE 2-4 bolt	R8
	SAE 2 bolt	W9

4	Ports position	CODE
	Side	L

CODE	Ports IN/OUT	5
GERMAN FLANGED PORTS		
Side	Type	
BB/BA	PLP 10 1-1,5-2-2,5-3,15-4-5-5,8-6,3-8-10	
GAS STRAIGHT THREAD PORTS (BSPP)		
Side	Type	
GC/GC	PLP 10 1-1,5-2-2,5-3,15-4	
GD/GD	PLP 10 5-5,8-6,3-8-10	
SAE STRAIGHT THREAD PORTS (ODT)		
Side	Type	
OB/OA	PLP 10 1-1,5-2-2,5-3,15-4-5-5,8-6,3	
OC/OB	PLP 10 8-10	

CODE	Combination type	6
V6	Standard	
V7	Common inlet	

CODE	Rotation	7
S	Left	
D	Right	

CODE	Version	8
0	Without outboard bearing (standard) no code	

CODE	Seals (a)	9
N	Buna (standard)	
V	Viton	

CODE	Cover options	10
	Cast iron mounting flange and rear cover (standard - no code)	
E	Aluminium mounting flange and cast iron rear cover	
L	Cast iron mounting flange and aluminium rear cover	
EL	Aluminium mounting flange and rear cover	

CODE	Shaft seal options	11
C	High back pressure seal with wiper seal	
D	Standard seal with wiper seal	
H	High back pressure seal	

CODE	Shaft arrangement	12
FS	Female spline	

02/07.2006

- (a) Choose the seals according to the temperature shown on page 3.
- (b) Mounting flange material on page 57 ÷ 59
Rear cover material on page 42

HOW TO ORDER POLARIS 20 MULTIPLE PUMPS

1
2
3
4
5
6
7
8
9
10
11
12
PLP20•4 – 82 E2 – L EA/EA /
Front section
20•4 – L EA/EA /
Intermediate section
20•4 – L **/EA – S7 – S 0 N EL C FS
Rear section

1	Type	PUMP TYPE
	in ³ /rev (cm ³ /rev)	
0.30 (4,95)		PLP 20•4
0.40 (6,61)		PLP 20•6,3
0.44 (7,29)		PLP 20•7,2
0.50 (8,26)		PLP 20•8
0.56 (9,17)		PLP 20•9
0.66 (10,9)		PLP 20•10,5
0.69 (11,23)		PLP 20•11,2
0.89 (14,53)		PLP 20•14
1.03 (16,85)		PLP 20•16
1.16 (19,09)		PLP 20•19
1.29 (21,14)		PLP 20•20
1.52 (24,84)		PLP 20•24,5
1.61 (26,42)		PLP 20•25
1.72 (28,21)		PLP 20•27,8
2.01 (33,03)		PLP 20•31,5

2	Drive shaft	CODE
	European tapered 1:8	82
	German tapered 1:5	54
	German tapered 1:5	55
	Straight	46
	SAE "A" spline (9 teeth)	03
	SAE spline (10 teeth)	01
	SAE "A" spline (11 teeth)	07
	SAE "A" straight	31
	Straight	49
	Straight	50
	SAE "B" spline	04
	SAE "B" straight	32
	DIN 54 82 spline	12
	Straight (only for version 6)	48
	Straight (only for version 8)	B1
	Tang	95

3	Mounting flange	CODE
	Europea	E2
	German	B2
	German 2 bolt	B4
	German 2 bolt	B5
	German 4 bolt	B6
	SAE "A" 2 bolt	S1
	SAE "A" 2 bolt	S2
	SAE "A" 2 bolt	S9
	SAE "B" 2 bolt	S5
	German	W8

4	Ports position	CODE
	Side	L

CODE	Ports IN/OUT		5
GERMAN FLANGED PORTS			
Side	Type		
BE/BC	PLP 20	4-6,3-7,2-8-9-10,5-11,2 14-16-19-20-24,5-25 27,8-31,5	

EUROPEAN FLANGED PORTS			
Side	Type		
EA/EA	PLP 20	4-6,3-7,2-8-9-10,5-11,2	
EB/EA	PLP 20	14-16-19-20-24,5-25 27,8-31,5	

SAE FLANGED PORTS (SSM)			
Side	Type		
MA/MA	PLP 20	4-6,3-7,2-8-9-10,5-11,2	
MB/MA	PLP 20	14-16-19-20	
MC/MB	PLP 20	24,5-25-27,8-31,5	

SAE FLANGED PORTS (SSS)			
Side	Type		
SA/SA	PLP 20	4-6,3-7,2-8-9-10,5-11,2	
SB/SA	PLP 20	14-16-19-20	
SC/SB	PLP 20	24,5-25-27,8-31,5	

GAS STRAIGHT THREAD PORTS (BSP)			
Side	Type		
GD/GD	PLP 20	4-6,3-7,2-8-9-10,5-11,2	
GE/GD	PLP 20	14-16-19-20-24,5-25-27,8-31,5	

SAE STRAIGHT THREAD PORTS (ODT)			
Side	Type		
OC/OC	PLP 20	4-6,3-7,2-8-9-10,5-11,2	
OD/OC	PLP 20	4-16-19-20-24,5 25-27,8-31,5	

01/10.03

HOW TO ORDER POLARIS 20 MULTIPLE PUMPS

Replaces: 01/10.03

6	Combination type	CODE
	Standard	S6
	Common inlet	S7
	Separate stages	Z6

7	Rotation	CODE
	Left	S
	Right	D

8	Version	CODE
	Without outboard bearing (standard) no code	0
	With outboard bearing	W8
	With outboard bearing	4
	With outboard bearing	5
	With outboard bearing	6
	With outboard bearing	7
	With outboard bearing	8
	With outboard bearing	9

CODE	Seals (a)	9
N	Buna (standard)	
V	Viton	

○

CODE	Cover options (b)	10
	Cast iron mounting flange and rear cover (standard - no code)	
E	Aluminium mounting flange and cast iron rear cover	
L	Cast iron mounting flange and aluminium rear cover	
EL	Aluminium mounting flange and rear cover	

CODE	Shaft seal options	11
C	High back pressure seal with wiper seal	
D	Paraolio standard con parapolvere	
H	High back pressure seal	

CODE	Shaft arrangement	12
FS	Female spline	

- (a) Choose the seals according to the temperature shown on page 3.
- (b) Mounting flange material on page 60 ÷ 64
Rear cover material on page 43

○ 02/07.2006

HOW TO ORDER POLARIS 30 MULTIPLE PUMPS

1
2
3
4
5
6
7
8
9
10
11

PLP30•22 – 83 E3 – L ED/EB /

Front section

30•22 – L ED/EB /

Intermediate section

30•22 – L ED/EB – M6 S 0 N C FS

Rear section

1	Type	PUMP TYPE
	in ³ /rev (cm ³ /rev)	
	1.34 (21,99)	PLP 30•22
	1.63 (26,70)	PLP 30•27
	2.11 (34,55)	PLP 30•34
	2.40 (39,27)	PLP 30•38
	2.68 (43,98)	PLP 30•43
	3.16 (51,83)	PLP 30•51
	3.74 (61,26)	PLP 30•61
	4.50 (73,82)	PLP 30•73
	4.98 (81,68)	PLP 30•82
	5.56 (91,10)	PLP 30•90

2	Drive shaft	CODE
	European tapered 1:8	83
	European tapered 1:8	84
	German tapered 1:5	56
	Straight	41
	SAE "B" spline	A8
	SAE "BB" spline	A5
	SAE "B" spline	04
	SAE "BB" spline	05
	SAE "B" straight	32
	SAE "BB" straight	33

3	Mounting flange	CODE
	European	E3
	European	E4
	German	B3
	SAE "B" 2 bolt	S5
	SAE "B" 2 bolt	U3

4	Ports position	CODE
	Side	L

5	Ports IN/OUT	CODE
GERMAN FLANGED PORTS		
	Type	Side
	22-27-34-38-43 46-51-61-73-82-90	PLP30 BM/BL
EUROPEAN FLANGED PORTS		
	Type	Side
	22-27-34-38-43 46-51-61	PLP30 ED/EB
	73-82-90	PLP30 EF/ED

CODE	Ports IN/OUT			5
SAE FLANGED PORTS (SSM)				
	Side	Rear	Type	
MB/MA			PLP 30	22
MC/MB			PLP 30	27-34
MD/MC			PLP 30	38-43-46-51
ME/MD			PLP 30	61-73-82
MF/ME			PLP 30	90

SAE FLANGED PORTS (SSS)				
	Side	Rear	Type	
SB/SA			PLP 30	22
SC/SB			PLP 30	27-34
SD/SC			PLP 30	38-43-46-51
SE/SD			PLP 30	61-73-82
SF/SE			PLP 30	90

GAS STRAIGHT THREAD PORTS (BSPP)				
	Side	Rear	Type	
GF/GF			PLP 30	22-27-34-38-43-46-51
GG/GF			PLP 30	61-73
GH/GG			PLP 30	82-90

SAE STRAIGHT THREAD PORTS (ODT)				
	Side	Rear	Type	
OF/OD			PLP 30	22-27-34
OG/OF			PLP 30	38-43-46-51
OH/OG			PLP 30	61-73-82-90

CODE	Combination type	6
M6	Standard	

CODE	Rotation	7
S	Left	
D	Right	

CODE	Version	8
0	Without outboard bearing (standard) no code	

CODE	Seals (a)	9
N	Buna (standard)	
V	Viton	

CODE	Shaft seal options	10
C	High back pressure seal with wiper seal	
D	Standard seal with wiper seal	
H	High back pressure seal	

CODE	Shaft arrangement	11
FS	Female spline	

(a) Choose the seals according to the temperature shown on page 3.

01/10.03

HOW TO ORDER POLARIS DOUBLE PUMPS DIFFERENT GROUPS

Replaces: 01/10.03

PLP30/PLP20

1	2	3	4	5	6	7	8	9	10	11
Pump type	Drive shaft	Mount. flange	Ports posit.	Ports IN/OUT	Comb. type	Rotation	Version	Shaft arrang.	Cover options	Seals
PLP30•22 - 83 E3 - L ED/EB /										
Front section										
20•4 - L EA/EA -					S - 0 - FS - L - N					
					Rear section					

PLP30/PLP10

PLP30•22 - 83 E3 - L ED/EB - 52 /										
Front section										
10•1 - L BB/BA -					S - 0 - FS - L - N					
					Rear section					

PLP20/PLP10

PLP20•4 - 82 E2 - L EA/EA - 51 /										
Front section										
10•1 - L BB/BA -					S - 0 - FS - EL - N					
					Rear section					

02/07.2006

1	Type	PUMP TYPE
	in ³ /rev (cm ³ /rev)	
	The same of multiple pumps	PLP ..
2	Drive shaft	CODE
	The same of multiple pumps	...
3	Mounting flange	CODE
	The same of multiple pumps	...
4	Ports position	CODE
	Side	L
5	Ports IN/OUT	CODE
	The same of multiple pumps	../..
6	Combination type	CODE
	PLP30/20 Standard - No code	N6
	PLP30/20 Common inlet	N7
	PLP30/20 Separate stages	Z6
	PLP30/10 Standard - No code	Q6
	PLP30/10 Common inlete	Q7
	PLP20/10 Standard - No code	T6
	PLP20/10 Common inlet	T7
	PLP20/10 Separate stages	Z6

CODE	Rotation	7
S	Left	
D	Right	

CODE	Version	8
...	The same of multiple pumps	

CODE	Shaft arrangement	9
FS	Female spline	

CODE	Cover options (a)	10
	Cast iron mounting flange and rear cover (standard - no code)	
E	Aluminium mounting flange and cast iron rear cover (only for PLP20/10)	
L	Cast iron mounting flange and aluminium rear cover	
EL	Aluminium mounting flange and rear cover (only for PLP20/10)	

CODE	Seals	11
	The same of multiple pumps	

- (a) Mounting flange material:
 PLP 20 on page 60 ÷ 64 - PLP 30 on page 65 ÷ 67
 Rear cover material:
 PLP 10 on page 43 ÷ 44 - PLP 20 on page 44

NOTES

01/10.03

Our policy is one of continuous improvement in product. Specification of items may, therefore, be changed without notice.

Casappa: Fluid Power Design at 360°

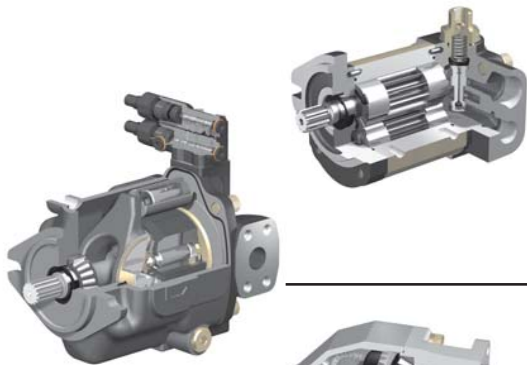

WHISPER

Gear pumps.
High performance, low noise.

PLATA

Variable displacement axial piston pumps,
for open circuit.



STRADA

Fixed displacement bent axis piston pumps,
for truck applications.



MAGNUM

Cast iron gear pumps and
motors of three part construction.



FORMULA

Cast iron gear pumps,
for truck applications.



KAPPA

Cast iron gear pumps and
motors of two part construction.



POLARIS

Gear pumps and
motors in aluminium.



UpEasy

Double acting hydraulic hand pumps
with or without reservoir.



IKRON
Fluid Filtration

Filters : suction filters, return filters, in line filters spin-on
type, for medium and high pressure filters.

CASAPPA
FLUID POWER DESIGN

CASAPPA S.p.A. - Parma - Italy - Tel.: + 39 0521 304111 - Fax: + 39 0521 804600

CASAPPA Corp. - Batavia, IL 60510 U.S.A. - Phone: 630 761-0041 - Fax: 630 761-0048

CASAPPA GmbH - Plüderhausen - Germany - Tel.: + 49 (0)7181 989830 - Fax: + 49 (0)7181 989831

CASAPPA SARL - La Rochelle - France - Tel.: + 33 (0)5 46372433 - Fax: + 33 (0)5 46423907

www.casappa.com
e-mail: info@casappa.com

SHOP ONLINE at www.airlinehyd.com

800-999-7378