

saip.it



# L/LAV/AMP Type

Screwed  
Diaphragm  
Accumulators  
L/LAV/AMP  
for pressure up to  
330 barg

# Screwed Diaphragm Accumulators L/LAV/AMP



## Operating principle

One of the primary functions of accumulators is to store a certain amount of pressurized fluid from a hydraulic system, then return it, in whole or in part, to the system when required. Diaphragm accumulators function like a hydraulic spring: the gas (nitrogen) contained in the rubber diaphragm is separated from the system fluid. When the system's hydraulic pressure exceeds the nitrogen's precharge pressure, the fluid enters the accumulator and is stored as potential energy within, thanks to the gas's compressibility. When the system fluid pressure decreases, the nitrogen pressure expands and returns the stored fluid to the system. Operating pressures appropriate for the maximum allowable pressure allow a pressurized liquid to be accumulated, stored, and recovered at any time. As pressurized vessels, they must be sized for the maximum (over) operating pressure, taking into account the acceptance standards applicable in the country of installation. Our screwed diaphragm accumulators are repairable and refillable with a rubber separator element. These hydraulic accumulators are compact and easy to maintain, making them ideal for hydraulic applications. Volumes range from 0.05 to 2.5 liters, and pressures up to 330 barg. The gas valve fills the membrane with nitrogen up to the required precharge pressure  $P_0$  (special equipment must be used for precharging).

The bottom plate, located at the bottom of the diaphragm, rests against the lower part of the body, preventing extrusion when the gas pressure is higher than the fluid pressure. This prevents the diaphragm from entering the fluid conduit and being destroyed.

## Product Description

Repairable diaphragm accumulator with seamless body for use in mobile machines and stationary systems.

## Applications

- Energy reserve in systems with intermittent operation due to pump power reduction.
- Energy reserve for emergencies, such as in the event of a motor-pump unit failure or power failure.
- Compensation for losses due to leakage.
- Pressure compensator (balancer).
- Vibration damping in the event of periodic oscillations.
- Volume compensation in the event of pressure and temperature variations.
- Hydraulic spring for vehicle suspensions.
- Shock absorption in the event of mechanical impact.
- Pulsation damping

## Suggested positions for certain applications

The fluid-side connection is available with the threaded connections shown in the table.

The technical data and characteristics of the hydraulic accumulator are shown on the appropriate marking and/or label affixed to the accumulator body.

Screwed-in diaphragm accumulators can be installed vertically, in an inclined position (oil fluid connection at the bottom), or horizontally. If the installation position is horizontal or inclined, the effective fluid volume and the maximum permissible flow rate of the operating fluid are reduced.

## Characteristics

- A** GAS VALVE
- B** UPPER CAP
- C** DIAPHRAGM SEAL RING
- D** DIAPHRAGM SUPPORT RING
- E** DIAPHRAGM
- F** BOTTOM CAP
- G** LOWER CAP
- H** FLUID CONNECTION

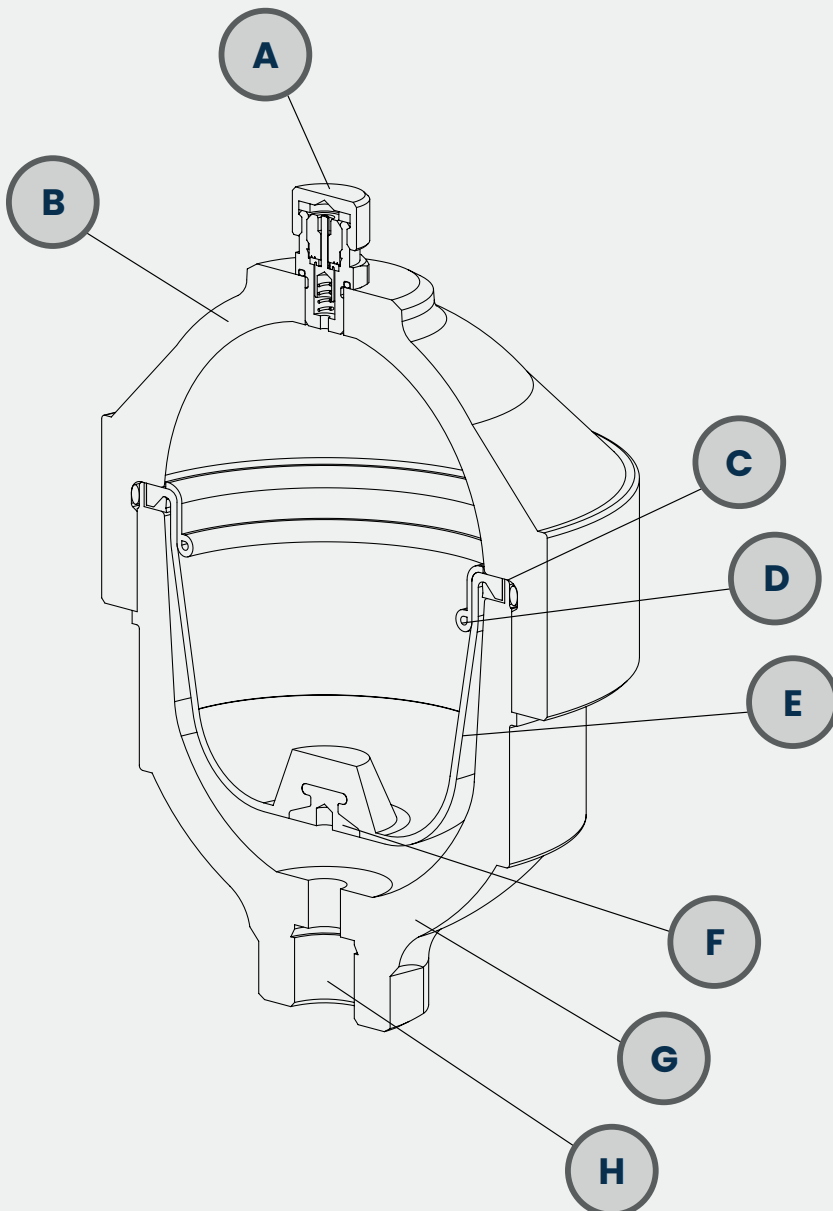

## General characteristics

Nominal volume from  
**0.05 to 2,5 litres**

Up to  
**MAX pressure 330 barg**

According to  
**PED 2014/68/EU**  
**EN 14359**  
**EN13445-3**  
**ASME VIII Div.1**

## Technical characteristics

Repairable construction

Screwed accumulators in  
carbon steel, stainless steel,  
and duplex

Standard coating  
for carbon steel

**RAL 9005**

Two-component anti-corrosive  
primer with water-based  
epoxy resins

*alternatively*  
treatment of zinc-nickel plating  
(800 h salt-spray resistance)  
Chemical nickel plating

Gas side connection  
5/8" UNF -M28x1,5

Fluid side connection  
(*see table*)

Separator element material  
(*see table*)

\* For ASME VIII Div. 1  
contact SAIP to verify  
design pressures

# L/LAV/AMP Type

Screwed diaphragm accumulators in carbon steel for pressures up to 330 BAR

## Description

Accumulator /Pulsation dampener type L - Valv. 5/8" UNF - Vol. 0,05 L - NBR - CARB. STEEL -M. 1/4" GAS

CODE EXAMPLE												
<b>L</b>	.	<b>1</b>	.	<b>0,05</b>	.	<b>1</b>	.	<b>O</b>	.	<b>A2</b>	.	<b>A</b>
1		2		3		4		5		6		7

1. ACCUMULATOR TYPE	
MODEL	barg
<b>L</b>	210
<b>LAV</b>	210
<b>AMP</b>	330

3. NOMINAL VOLUME	
<b>0,05</b>	L
<b>0,1*</b>	L
<b>0,35*</b>	L
<b>0,5*</b>	L
<b>0,75*</b>	L
<b>1,5</b>	L
<b>2,5</b>	L
<b>0,05</b>	L
<b>0,1*</b>	L
<b>0,35*</b>	L
<b>0,5*</b>	L

5. BODY MATERIAL	
<b>O</b>	Carbon steel
<b>OZN</b>	Zinc-Nickel plated carbon steel
<b>O2</b>	Kanigen-treated carbon steel

6. FLUID CONNECTION	
<b>A2</b>	M. 1/4" BSP-P
<b>M8</b>	F.M18x1,5
<b>G4</b>	F. 1/2" BSP-P
<b>M8</b>	F.M18x1,5
<b>G4</b>	F. 1/2" BSP-P
<b>M8</b>	F.M18x1,5
<b>G4</b>	F. 1/2" BSP-P
<b>M8</b>	F.M18x1,5
<b>G4</b>	F. 1/2" BSP-P
<b>M8</b>	F.M18x1,5
<b>G5</b>	F. 3/4" BSP-P
<b>M8</b>	F.M18x1,5
<b>G5</b>	F. 3/4" BSP-P
<b>A2</b>	M. 1/4" GAS
<b>M8</b>	F.M18x1,5
<b>G4</b>	F. 1/2" BSP-P
<b>M8</b>	F.M18x1,5
<b>G4</b>	F. 1/2" BSP-P
<b>M8</b>	F.M18x1,5
<b>G4</b>	F. 1/2" BSP-P

2. GAS CONNECTION (NITROGEN)	
<b>1</b>	5/8" UNF
<b>2</b>	M28x1,5

4. SEPARATOR ELEMENT MATERIAL	
<b>1</b>	Nitrile (NBR)
<b>2</b>	Butyl
<b>4</b>	Ethylene/propylene (EPDM)
<b>8</b>	Epichlorohydrin (ECO)
<b>10</b>	FKM
<b>21C</b>	FFKM

7. CERTIFICATION	
<b>A</b>	PED 2014/68/EU EN 14359:2017 EN13445-3:2021
<b>E</b>	PED 2014/68/EU ASME VIII Div.1

\* Volume for which FFKM diaphragm is available

**Description**

Accumulator /Pulsation dampener type L - Valv. 5/8" UNF - Vol. 0,05 L - NBR - AISI 316L - M. 1/4" GAS

CODE EXAMPLE												
L	.	1	.	0,05	.	1	.	X	.	A2	.	A
1		2		3		4		5		6		7

1. ACCUMULATOR TYPE
MODEL
L **

3. NOMINAL VOLUME	
0,05	L
0,1*	L
0,35*	L
0,5*	L
0,75*	L
1,5	L
2,5	L

5. BODY MATERIAL	
X	Stainless steel
D	Duplex

6. FLUID CONNECTION	
A2	M. 1/4" BSP-P
M8	F.M18x1,5
N4	F. 1/2" NPT
M8	F.M18x1,5
N4	F. 1/2" NPT
M8	F.M18x1,5
N4	F. 1/2" NPT
M8	F.M18x1,5
N5	F. 3/4" NPT
M8	F.M18x1,5
N5	F. 3/4" NPT

2. GAS CONNECTION (NITROGEN)	
1	5/8" UNF
2	M28x1,5

4. MATERIALE ELEMENTO SEPARATORE	
1	Nitrile (NBR)
2	Butyl
4	Ethylene/propylene (EPDM)
8	Epichlorohydrin (ECO)
10	FKM
21C	FFKM

7. CERTIFICATION	
A	PED 2014/68/EU EN 14359:2017 EN13445-3:2021
E	PED 2014/68/EU ASME VIII Div.1

** DESIGN PRESSURE [barg]		
L	Stainless steel	150
LAV		
L	Duplex	250
LAV		

\* Volume for which FFKM diaphragm is available

BLADDER COMPATIBILITY / TEMPERATURE / FLUID*			
1	Rubber Perbunan Nitrile (NBR)	-15 / +80°C	<p><b>Suitable for:</b></p> <ul style="list-style-type: none"> <li>• Mineral fats and oils</li> <li>• Aliphatic hydrocarbons (propane, butane, petrol, oils, mineral fats, diesel fuel, fuel oil, kerosene)</li> <li>• HFA - HFB - HFC fluids</li> <li>• Many diluted acids</li> <li>• Saline solutions</li> <li>• Water</li> <li>• Glycol water</li> </ul>
8	Epichlorohydrin (ECO)	-30 / +120°C	<p>Low gas permeability, good resistance to ozone, ageing and weathering.</p> <p><b>Suitable for:</b></p> <ul style="list-style-type: none"> <li>• Mineral fats and oils</li> <li>• Aliphatic hydrocarbons (propane, butane, petrol)</li> <li>• Silicone oils and greases</li> <li>• Water at room temperature</li> </ul>
2	Butyl	-20 / +100°C	<p><b>Suitable for:</b></p> <ul style="list-style-type: none"> <li>• Hot water up to 100° C</li> <li>• glycol-based brake fluids</li> <li>• silicone oils and greases</li> <li>• many acids and bases of phosphoric acid esters</li> <li>• salt solutions, polar solvents such as alcohols, ketones and esters</li> <li>• polyglycol-based hydraulic fluids</li> </ul>
4	Ethylene/propylene (EPDM)	-30 / +130°C	<p><b>Suitable for:</b></p> <ul style="list-style-type: none"> <li>• Hot water up to 100° C</li> <li>• glycol-based brake fluids</li> <li>• silicone oils and greases</li> <li>• many acids and bases of phosphoric acid esters</li> <li>• many polar solvents such as alcohols, ketones and esters</li> </ul>
21C	Perfluoroelastomer (FFKM)	-10 / +220° C	<p><b>Suitable for:</b></p> <ul style="list-style-type: none"> <li>• Mineral oils and greases, silicone oils and greases, animal and vegetable oils and fats</li> <li>• Aliphatic hydrocarbons (gasoline, butane, propane, natural gas), aromatic hydrocarbons (benzene, toluene), chlorinated hydrocarbons (tetrachloroethylene, carbon tetrachloride)</li> <li>• Fuels (regular, premium, and containing methanol or ethanol)</li> <li>• Non-flammable fluids in the HFD group</li> <li>• Strong acids (sulfuric, nitric, hydrochloric), strong bases (caustic soda, ammonia), aggressive organic solvents (ketones, esters, ethers, alcohols)</li> <li>• Strong oxidants (hydrogen peroxide, ozone), steam, and high temperatures</li> </ul>
10	Fluorinated Rubber (FKM)	-10 / +150°C	<p><b>Suitable for:</b></p> <ul style="list-style-type: none"> <li>• Mineral oils and fats, silicone oils and fats, animal and vegetable oils and fats</li> <li>• aliphatic hydrocarbons (petrol, butane, propane, natural gas), aromatic hydrocarbons (benzole, toluol)</li> <li>• chlorinated hydrocarbons (tetrachloroethylene, carbon tetrachloride)</li> <li>• fuels (normal, super and methanol-containing)</li> <li>• non-flammable fluids of the HFD group</li> </ul>

\* For use with different fluids and/or temperatures please contact SAIP

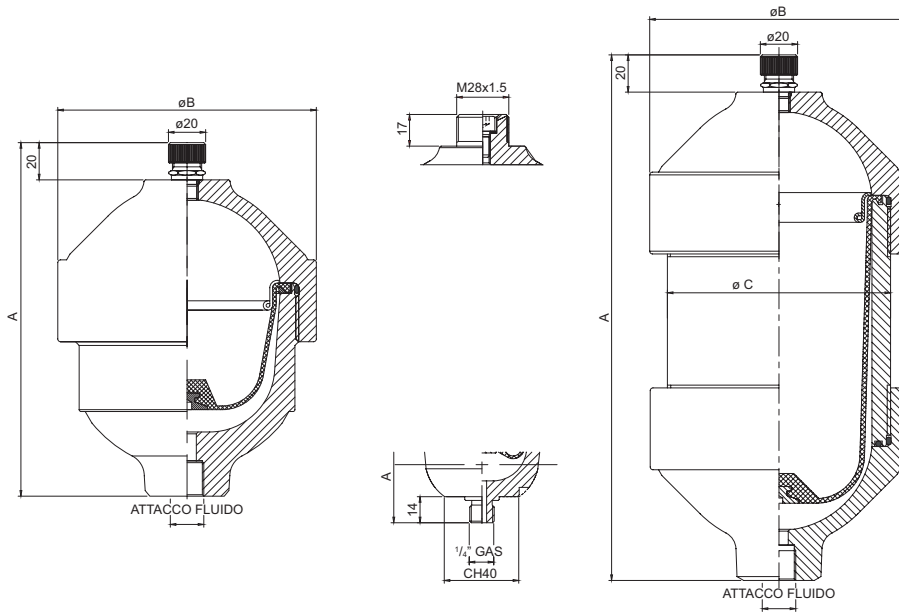

Type **L/LAV/AMP** Screwed diaphragm accumulators in carbon steel for pressures up to 330 BAR

Volume	Model	Effective gas volume	Nominal volume	Design pressure EN (*)	Gas connection	A	B	C	D	Fluid Connection	Weight
		[L]	[L]	[barg]		[mm]	[mm]	[mm]	[mm]		
0,05	L	0,05	0,05	210	5/8" UNF M28x1,5	109	64,5	-	CH40	M. 1/4" BSP-P	1,3
0,1	L	0,1	0,1			133	77	-	CH36	F.M18x1,5 F. 1/2" BSP-P	1,9
0,35	L	0,35	0,35			159	99	-	CH36	F.M18x1,5 F. 1/2" BSP-P	2,9
0,50	LAV	0,50	0,50			173,5	116	-	CH36	F.M18x1,5 F. 1/2" BSP-P	4
0,75	LAV	0,75	0,75			190	139	-	CH36	F.M18x1,6 F. 1/2" BSP-P	6
1,50	LAV	1,50	1,50			283	139	120	CH41	F.M18x1,4 F. 3/4" BSP-P	10
2,5	LAV	2,5	2,5			437	139	120	CH41	F.M18x1,4 F. 3/4" BSP-P	14
0,05	AMP	0,05	0,05	330	5/8" UNF M28x1,5	109	64,5	-	CH40	M. 1/4" BSP-P	1,3
0,1	AMP	0,1	0,1			133	77	-	CH36	F.M18x1,5 F. 1/2" BSP-P	1,9
0,35	AMP	0,35	0,35			159	99	-	CH36	F.M18x1,5 F. 1/2" BSP-P	2,9
0,50	AMP	0,50	0,50			173,5	116	-	CH36	F.M18x1,5 F. 1/2" BSP-P	4

Type **L/LAV** Diaphragm Accumulators in stainless steel and Duplex for pressures up to 250 bar

Volume	Model	Effective gas volume	Nominal volume	Stainless steel design pressure (*)	Duplex design pressure (*)	Gas connection	A	B	C	D	Fluid Connection	Weight
		[L]	[L]	[barg]	[barg]		[mm]	[mm]	[mm]	[mm]		
0,05	L	0,05	0,05	150	250	5/8" UNF M28x1,5	109	65	-	CH40	M. 1/4" BSP-P	1,3
0,1	L	0,1	0,1	150	250		133	79	-	CH36	F.M18x1,5 F. 1/2" NPT	1,9
0,35	L	0,35	0,35	150	250		159	99	-	CH36	F.M18x1,5 F. 1/2" NPT	2,9
0,50	LAV	0,50	0,50	150	210		173,5	116	-	CH36	F.M18x1,5 F. 1/2" NPT	4
0,75	LAV	0,75	0,75	150	210		190	139	-	CH36	F.M18x1,6 F. 1/2" NPT	6
1,50	LAV	1,50	1,50	150	210		283	139	120	CH41	F.M18x1,4 F. 3/4" NPT	10
2,5	LAV	2,5	2,5	150	210		437	139	120	CH41	F.M18x1,4 F. 3/4" NPT	14

\*Design pressure calculated according to EN14359:2017 (for pressure values according to other norms please contact SAIP)

## Sizing

When sizing an accumulator, several factors must be considered:

- Minimum (P1) and maximum (P2) working pressures
- Minimum (T1) and maximum (T2) working temperatures
- Precharge pressure (P0)
- Required volumes

The formulas for correct sizing can be found in the data sheet:

**GENERAL INFORMATION -> SIZING**

## Certifications

All hydraulic accumulators are pressure vessels and are subject to the national regulations and directives in force in the country of installation.

L-LAV-AMP accumulators are built in accordance with the European Pressure Equipment Directive 2014/68/EU, reference standards EN 14359:2017 and EN 13445-3:2021; they can be compliant with ASME VIII Div. 1.

For use with dangerous fluids (group 1) SAIP needs to be contacted.  
For other countries, applications, norms, SAIP needs to be contacted.

## Status conditions

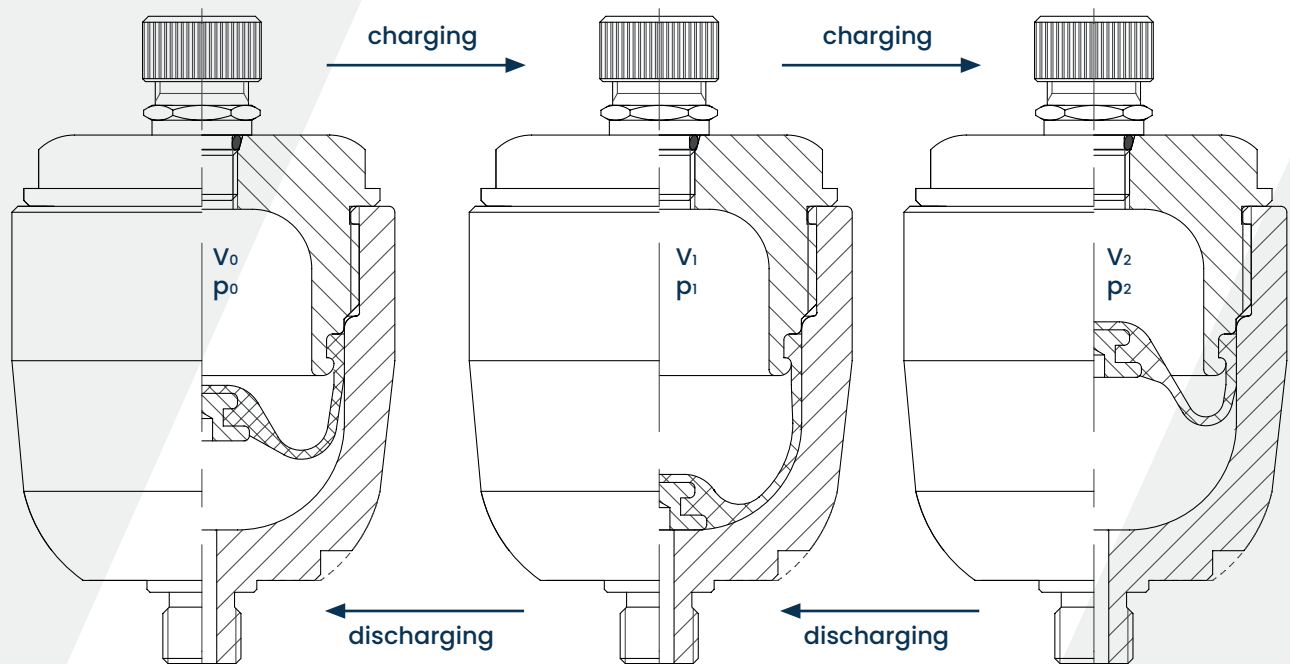

## Usage information

Please refer to the following SAIP documents:

- WA USER AND MAINTENANCE MANUAL
- USER MANUAL FOR THE STORAGE AND PRESERVATION OF HYDRAULIC ACCUMULATORS/PULSATION DAMPENERS

## Safety Equipment

**Warning:**

**Hydropneumatic accumulators must be protected against operation beyond permissible limits in accordance with Directive 2014/68/EU on pressure equipment.**

In order not to exceed the maximum operating pressure, SAIP recommends the use of a safety block. (see Saip BSF catalogue)



**CAUTION!**  
HIGH PRESSURE ACCUMULATOR  
NEVER USE OXYGEN OR SHOP AIR.

1. DO NOT OPERATE WITHOUT SUFFICIENT DRY NITROGEN GAS PRECHARGE.
2. RELEASE ALL PRESSURE PRIOR TO SERVICING OR DISASSEMBLY.
3. CONSULT THE INSTRUCTION MANUAL BEFORE USE.
4. DO NOT OPERATE BEYOND STAMPED MAXIMUM WORKING PRESSURE.
5. DO NOT WELD OR MODIFY THIS UNIT IN ANY WAY.

**SAIP**



use & maintenance manual

## Spare parts Carbon steel

Model	Effective volume	Complete diaphragm kit	Only 5/8" UNF nitrogen valve	for M28x1,5
L	0,05	KRL0,05-##PA16-01 *	VALPRE58OZ-IV2	VITCM814TF-O12-B + GUAUSITM8-1
	0,1	KRL0,1-##PA16-01*		
	0,35	KRL0,35-##PA16-01*		
LAV	0,5	KRLAV0,5-##PA16-01*		
	0,75	KRLAV0,75-##PA22-01*		
	1,5	KRLAV1,5-##PA22-01*		
	2,5	KRLAV2,5-##O32-01		
AMP	0,05	KRAMP0,05-##O16-01		
	0,1	KRAMP0,1-##O16-01		
	0,35	KRAMP0,35-##O16-01		
	0,5	KRAMP0,5-##O16-01		

PA up to P0 <= 120 bar and O for P0 > 120 bar

## Spare parts Stainless steel and Duplex

Model	Effective volume	Material	Complete diaphragm kit	Only 5/8" UNF nitrogen valve	for M28x1,5
L	0,05	Stainless steel	KRL0,05-##X16-01	VALPRE58X-10V0	VITCM814TF-X48+ GUAUSITM8-1X
		Duplex	KRL0,05-##D16-01	VALPRE58D-10V0	
	0,1	Stainless steel	KRL0,1-##X16-01	VALPRE58X-10V0	
		Duplex	KRL0,1-##D16-01	VALPRE58D-10V0	
	0,35	Stainless steel	KRL0,35-##X16-01	VALPRE58X-10V0	
		Duplex	KRL0,35-##D16-01	VALPRE58D-10V0	
LAV	0,5	Stainless steel	KRLAV0,5-##X16-01	VALPRE58X-10V0	
		Duplex	KRLAV0,5-##D16-01	VALPRE58D-10V0	
	0,75	Stainless steel	KRLAV0,75-##X22-01	VALPRE58X-10V0	
		Duplex	KRLAV0,75-##D22-01	VALPRE58D-10V0	
	1,5	Stainless steel	KRLAV1,5-##X22-01	VALPRE58X-10V0	
		Duplex	KRLAV1,5-##D22-01	VALPRE58D-10V0	
	2,5	Stainless steel	KRLAV2,5-##X32-01	VALPRE58X-10V0	
		Duplex	KRLAV2,5-##D32-01	VALPRE58D-10V0	

Replace ## with the code of the rubber part as per table below

<b>1</b>	Nitrile (NBR)	<b>4</b>	Ethylene/propylene (EPDM)
<b>8</b>	Epichlorohydrin (ECO)	<b>10</b>	Fluororated Rubber (FKM)
<b>2</b>	Butyl	<b>21C</b>	Perfluoroelastomer (FFKM)**

\*\*Available only for the volumes mentioned at page 4

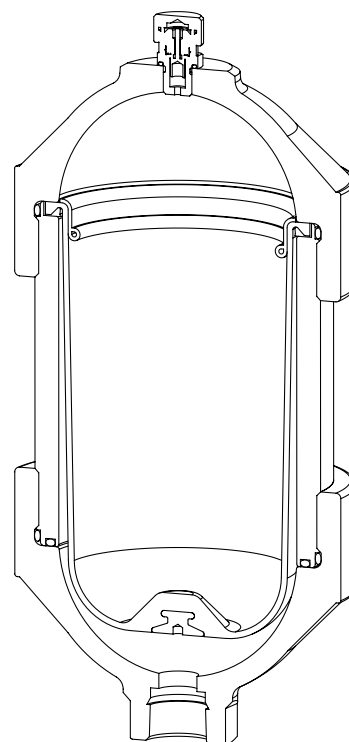
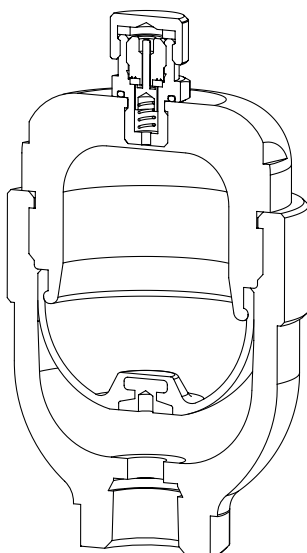

# Accessories

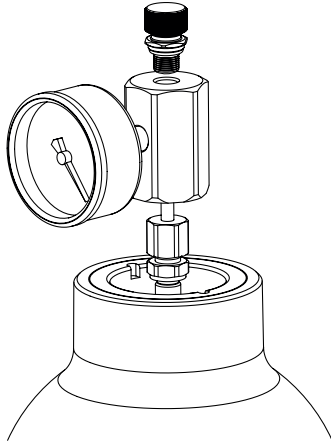

## Nitrogen side pressure monitoring

Nozzle assembly with provision for mounting pressure gauge and/or fitting with rupture disk.

For codes or characteristics contact SAIP

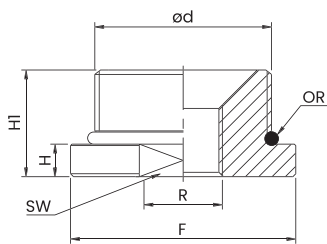

## Adapters and reductions for Fluid connection

Adaptors and reductions for fluid connection: supliable on request in different dimensions, materials, etc. For codes or characteristics please contact SAIP

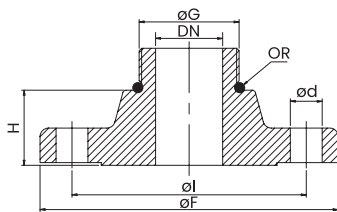

## Flange for fluid connection

Flange for fluid connection: supliable on request for norm (i.e. ASME B16.5, EN1092-1) dimensions, different material, etc. For codes or characteristics please contact SAIP

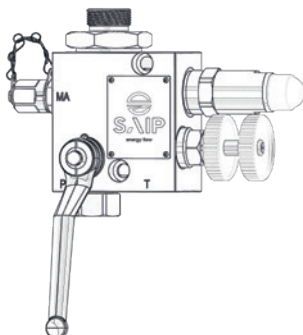

## Safety block

See BSF saip catalogue

## Mounting clamps light series

### Mounting clamps

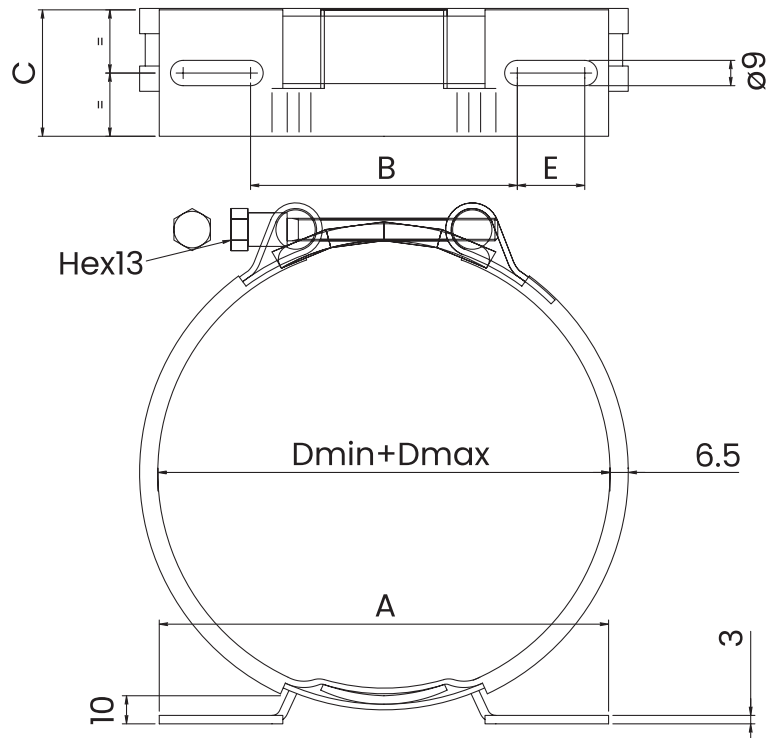

### Dimensions

Type		Description							
AISI 316L	CARBON STEEL	Dmin	Dmax	A	B	C	E	Peso	Use with L/LAV/AMP
		[mm]	[mm]	[mm ±1]	[mm ±1]	[mm ±0,5]	[mm ±0,5]	[kg]	
CFXZ96LF120	CFOZ96LF120	91	96	124	81	45	13	0,3	LAV 0,5 - AMP 0,5
CFXZ96LF160	CFOZ96LF160	91	96	144	93	45	17	0,5	
CFX102LF160	CFOZ102LF160	97	105	144	93	45	17	0,5	L 0,35 - AMP 0,35
CFX120LF160	CFOZ120LF160	115	123	144	93	45	17	0,5	LAV 0,75-1,5-2,5



L/LAV/AMP - October 2025

[saip.it](http://saip.it)

**SAIP S.r.l.**  
Hydropneumatic  
Accumulator Company

Via Lambro 23/25/27  
20073 Opera (MI) Italy  
P.Iva 10218550159

[DONWLOAD  
DATA SHEET](#)

