

MS11 - MSE11

HYDRAULIC MOTORS



T E C H N I C A L C A T A L O G



CHARACTERISTICS

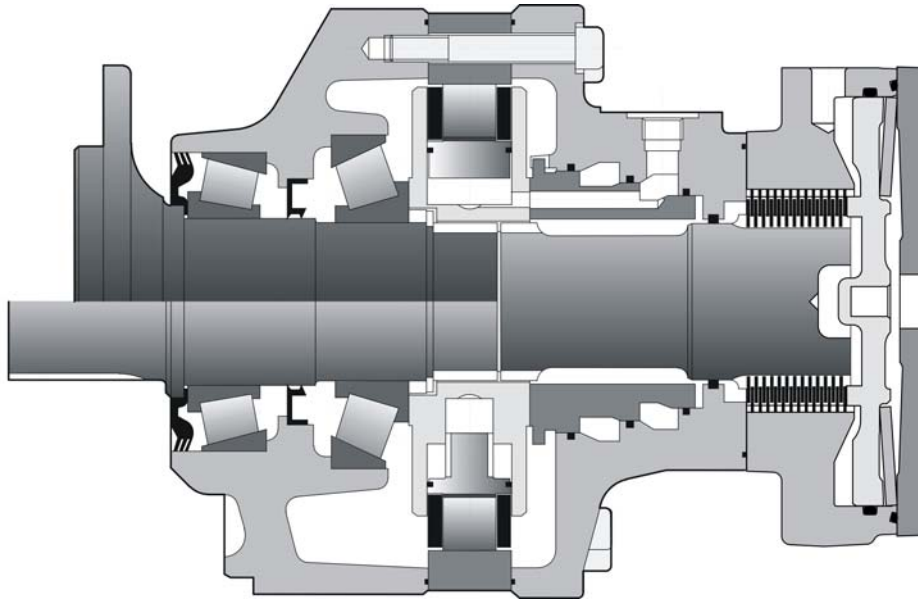

Motor inertia 0.05 kg.m²

	C	Displacement		Theoretical torque		1	Max. power		Max. speed		Max. pressure
		1	2	at 100 bar			1	2	1	2	
		cm ³ /tr [cu.in./rev.]	cm ³ /tr [cu.in./rev.]	Nm	[lb.ft]		kW [HP]	preferred kW [HP]	non-preferred kW [HP]	tr/min [RPM]	
Cams with equal lobes MS11		7	730 [44.5]	365 [22.3]	1,161 [590]	50 [67]	33 [44]	25 [34]	200		450 [6,527]
		8	837 [51.0]	419 [25.5]	1,331 [677]				195		
		9	943 [57.5]	472 [28.8]	1,499 [762]				190		
		0	1,048 [63.9]	524 [32.0]	1,666 [847]				185		
		1	1,147 [70.0]	574 [35.0]	1,824 [927]				180		
		2	1,259 [76.8]	630 [38.4]	2,002 [1,018]				170	175	
Cams with unequal lobes MSE11		9	1,263 [77.0]	632 [38.5]	2,008 [1,021]	50 [67]	33 [44]	25 [34]	170	190	400 [5,802]
		0	1,404 [85.6]	702 [42.8]	2,232 [1,135]				155	185	
		1	1,536 [93.7]	768 [46.8]	2,442 [1,242]				140	180	
		2	1,687 [102.9]	844 [51.4]	2,682 [1,364]				130	165	
Cams with unequal lobes	MS11 A	1,048 [63.9]	629 [38.4]	419 [25.6]	1,666 [847]	50 [67]	33 [44]	25 [34]			450 [6,527]
Cams with unequal lobes	MSE11 A	1,404 [85.6]	843 [51.4]	561 [34.2]	2,232 [1,135]	50 [67]	33 [44]	25 [34]	120		400 [5,802]

1 First displacement

2 Second displacement

* See option "M" for higher speed.

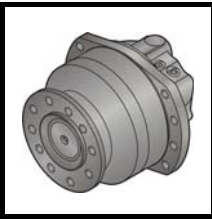
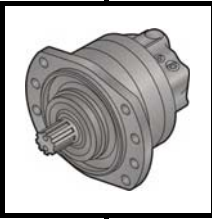
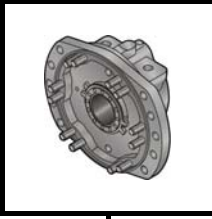
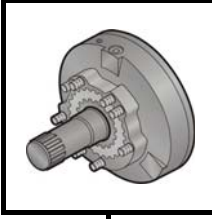
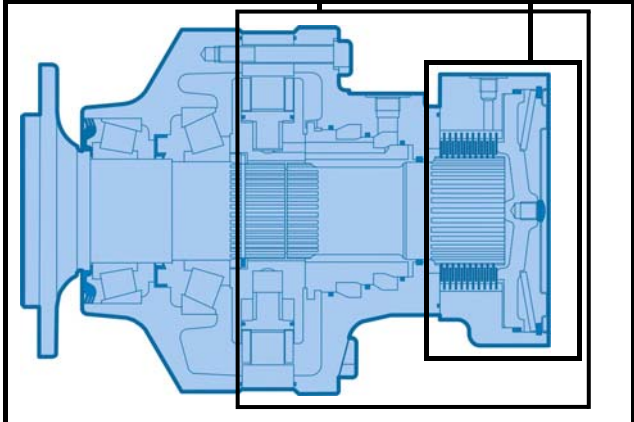

CONTENT

	MODULARITY	4	Modularity and Model code
	MODEL CODE	6	
	WHEEL MOTOR	8	Wheel motor
	Dimensions for standard (1110) 1-displacement motor	8	
	Dimensions for standard (1110) 2-displacement motor	9	
	Dimensions for standard (1110) Twin-Lock™	9	
	Support types	10	
	Studs	10	
	Support types (continued)	12	
	Load curves (continued)	13	
	SHAFT MOTOR	15	Shaft motor
	Dimensions for standard (2A50) 1-displacement motor	15	
	Dimensions for standard (2A50) 2-displacement motor	15	
	Support types	16	
	Splined coupling	16	
	Load curves	17	
	VALVING SYSTEMS AND HYDROBASES	19	Valving systems and hydrobases
	Dimensions for 1-displacement valving	19	
	Cylinder block splines	19	
	Exchange	22	
	Hydraulic connections	24	
	BRAKES	27	Brake
	Rear brake	27	
	Drum brake (315 x 80)	28	
	OPTIONS	29	Options



MODUL

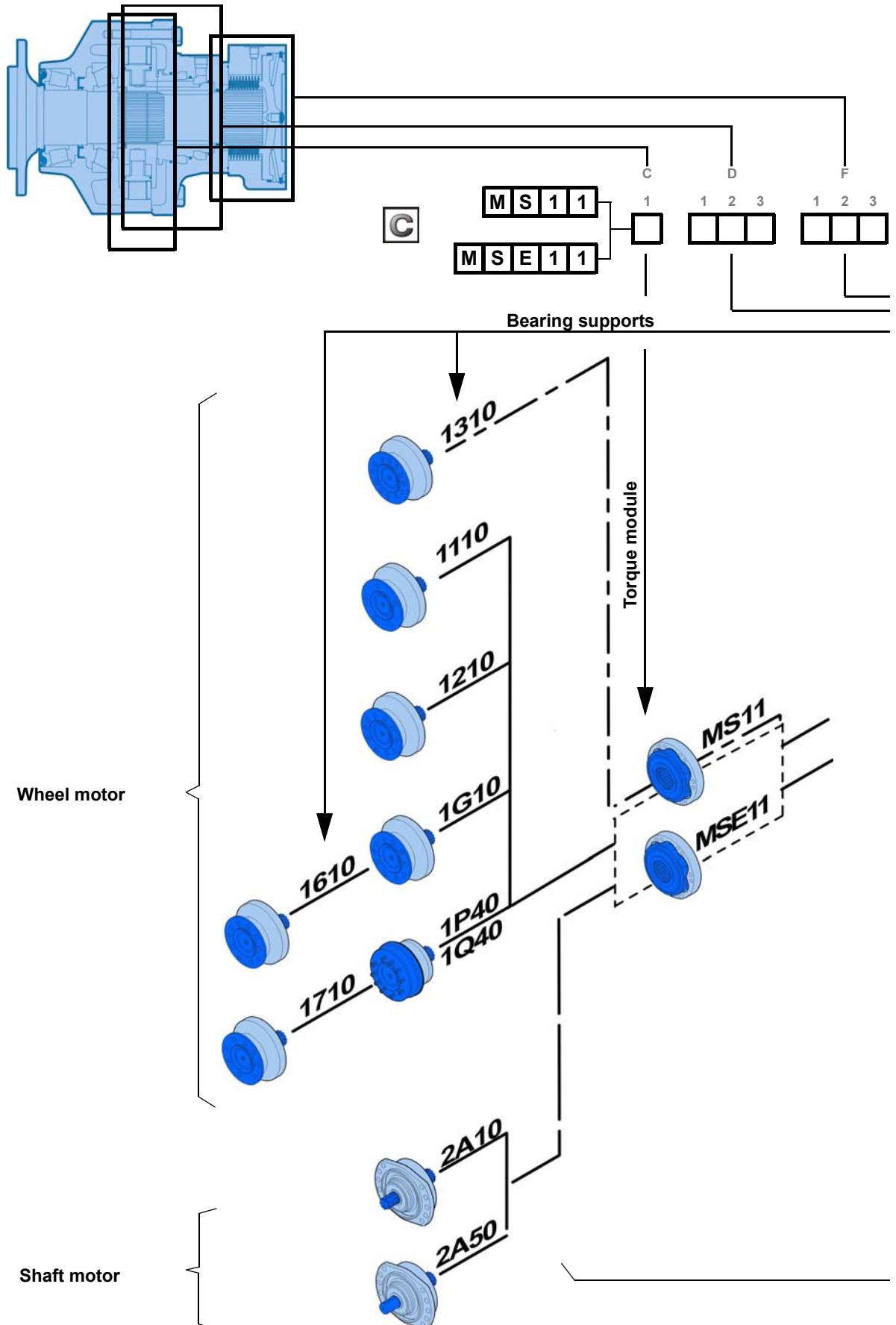



ARITY

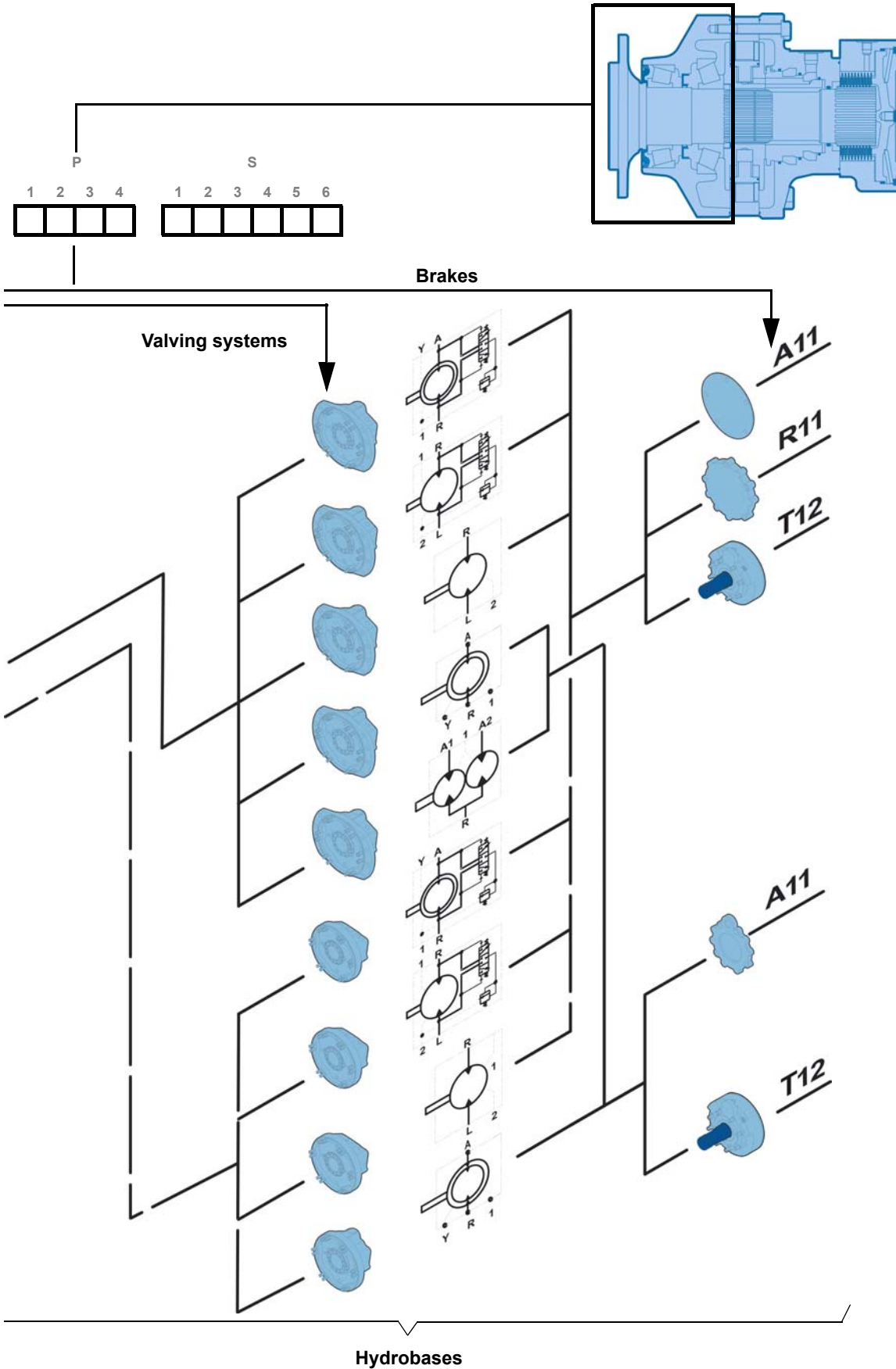

Modularity and Model code

Wheel motor

Shaft motor

Valving systems and hydrobases

Brake

Options



MODEL

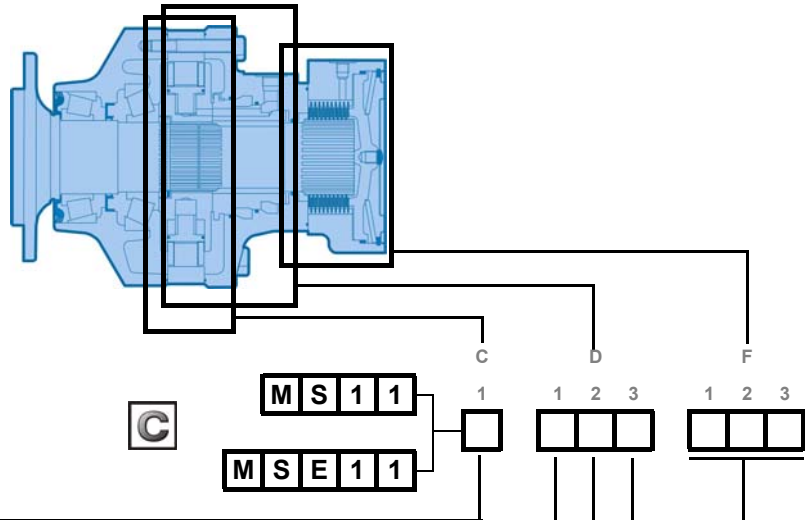

		cm ³ /tr [cu.in./rev.]	
		1	2
Cams with equal lobes	MS11	7	730 [44.5] 365 [22.3]
		8	837 [51.0] 419 [25.5]
		9	943 [57.5] 472 [28.8]
		0	1,048 [63.9] 524 [32.0]
		1	1,147 [70.0] 574 [35.0]
		2	1,259 [76.8] 630 [38.4]
Cams with unequal lobes	MSE11	9	1,263 [77.0] 632 [38.5]
		0	1,404 [85.6] 702 [42.8]
		1	1,536 [93.7] 768 [46.8]
		2	1,687 [102.9] 844 [51.4]

Cams with unequal lobes	MS11	A	1,048 [63.9]	629 [38.4]
				419 [25.6]
Cams with unequal lobes	MSE11	A	1,404 [85.6]	843 [51.4]
				561 [34.2]

- 1 First displacement
- 2 Second displacement

1-displacement valving	1
2-displacement & Twin-Lock™ valving (Clockwise)	D Ratio 2 E Ratio <2 F Ratio >2
2-displacement & Twin-Lock™ valving (Counterclockwise)	G Ratio 2 H Ratio <2 J Ratio >2

Without mounting	1	4	D
With mounting	2	5	E
	1 Displacement	2 Displacement	Exchange Twin-Lock™

No transmission cover		0
ISO 6162 flanges	1 DN 19	1
ISO 9974-1 connections	2 DN 13	1
ISO 6162 flanges	1 DN 19	2
ISO 1179-1 connections	2 DN 13	2
ISO 1179-1 connections	G3/4	3
ISO 9974-1 connections	M27 x 2	4
ISO 6162 flanges	1 DN 13	7
ISO 11926-1 connections	2 DN 19	7
ISO 11926-1 connections	1" 1/16-12 UNF	A
	1 First displacement	
	2 Second displacement	

Without brake	Simple plate Reinforced plate
Brake	Screwed environmental cover

A	1	1
R	1	1
T	1	2



CODE

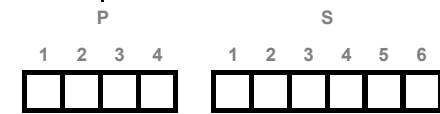
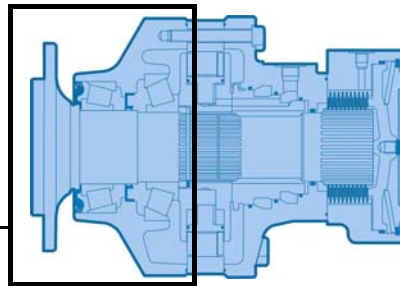

0	Without bearing support
1	Without mounting
2	Lug mounting

Without shaft	0
5 x Ø24 on Ø225	1
10 x Ø22 on Ø225	2
8 x Ø22 on Ø275	7
12 x Ø20 on Ø205	3
10 x Ø22 on Ø225	6
10 x Ø24 on Ø225	G
Drum brake (315 x 80)	Mineral P DOT 3&4 Q
For male shaft bearing support	A

Without studs	1
With studs + nuts	2
With studs	3
M threaded holes	4

Male shafts	
NF E22-141 splines	1
DIN 5480 splines	5

Connection	
Without cable	1
Right-hand cable outlet	2
Left-hand cable outlet	3
Without cable	Q
Right-hand cable outlet	R
Left-hand cable outlet	S
M14 x 1.5	
M10 x 1	

For drum brake (315 x 80)

Without Options or Adaptations	0
Fluorinated elastomer seals	1
T4 speed sensor (without rotation direction)	2
Brake environmental cover without plug	3
Drainage	5
Industrial bearing support	6
Diamond™	7
Predisposition for speed sensor	8
Double-centering valving cover	9
Hollow shaft	A
Drain on the bearing support	B
Abrasive environment	C
Special paint or without paint	D
Reinforced sealing	E
Special wheel rim mounting	G
High performance	H
Surface heat treatment of the shaft	J
High speed	M
TD speed sensor (two phase shifted frequencies)	Q
TR speed sensor (digital rotation direction)	S
Soft Shift™	T

Modularity and Model code

Wheel motor

Shaft motor

Valving systems and hydrobases

Brake

Options



Methodology :

This document is intended for manufacturers of machines that incorporate Poclair Hydraulics products. It describes the technical characteristics of Poclair Hydraulics products and specifies installation conditions that will ensure optimum operation. This document includes important comments concerning safety. They are indicated in the following way :This document also includes essential



Safety comment.

operating instructions for the product and general information. These are indicated in the following way:



Essential instructions.



General information.



Information on the model number.



Weight of component without oil.



Volume of oil.



Units.



Tightening torque.



Screws.



Information intended for Poclair-Hydraulics personnel.

The views in this document are created using metric standards. The dimensional data is given in mm and in inches (inches are given in brackets in italics).



Dimensions for standard (1110) 1-displacement motor

	86 kg [189 lb]	112 kg [246 lb]
	2 L [120 cu.in]	1.5 L [90 cu.in]

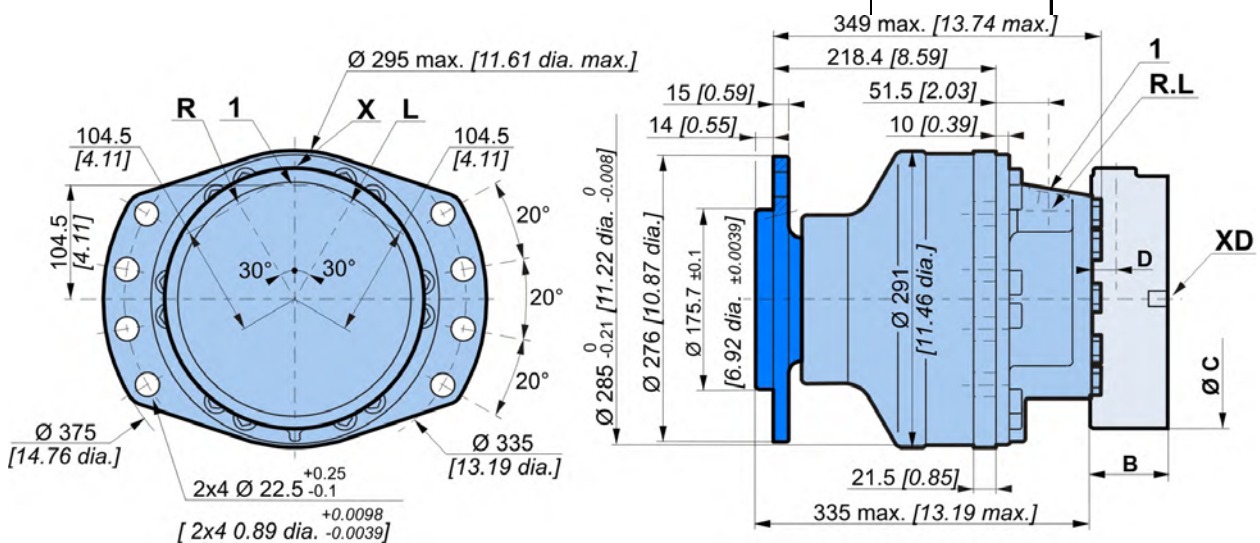



WHEEL MOTOR

Dimensions for standard (1110) 2-displacement motor

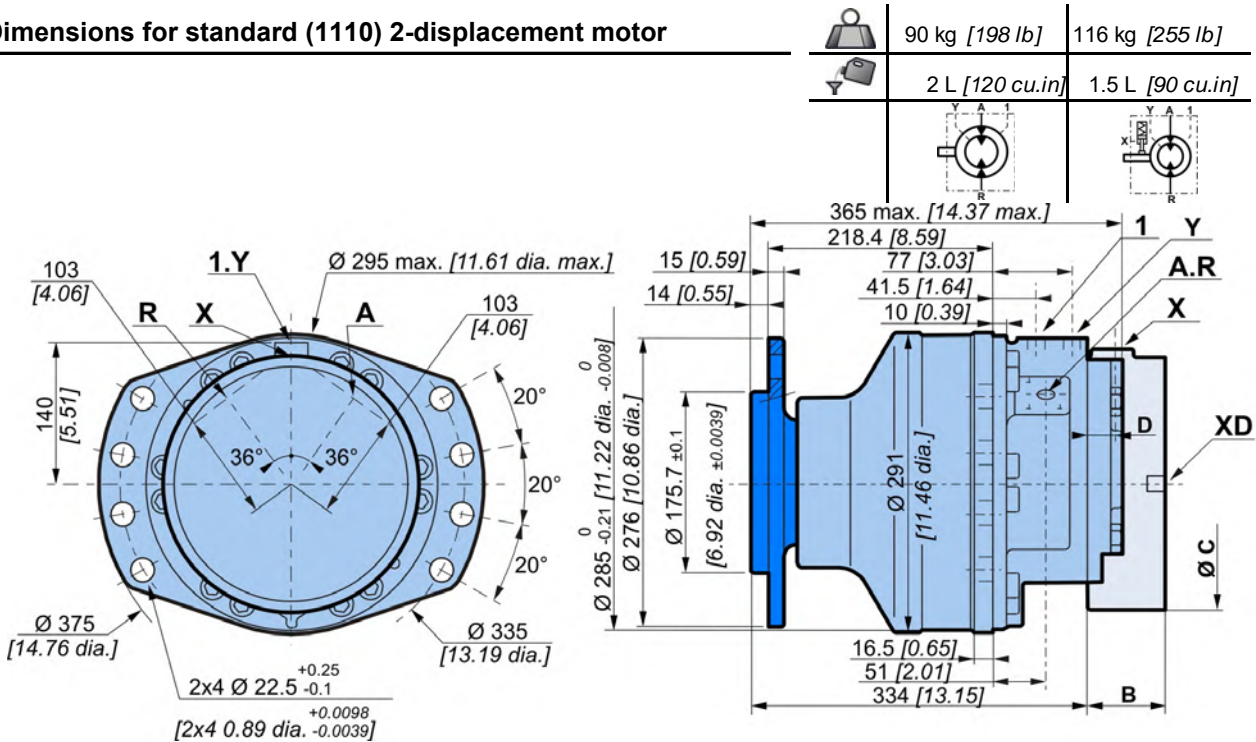

Dimensions for standard (1110) Twin-Lock™

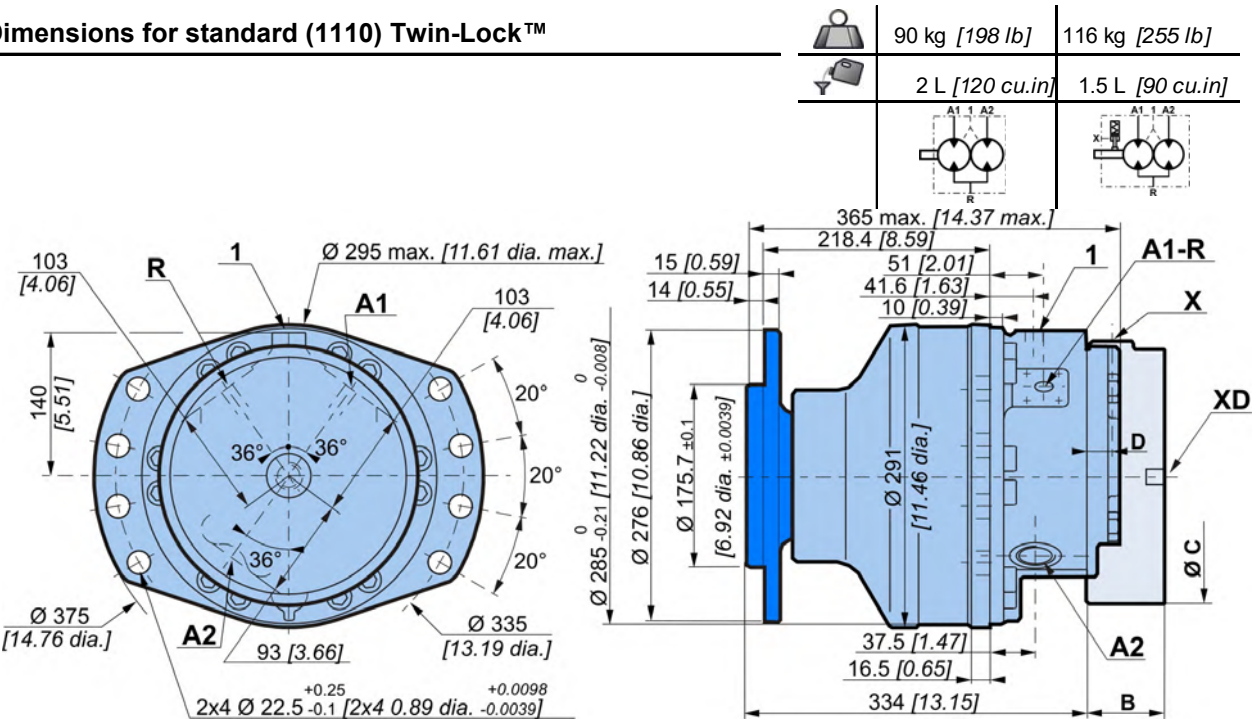

C	T12
B	92.5 [3.64]
C	Ø273.6 [10.77]
D	25.0 [0.96]

Also see 'Valving systems and hydrobases' section (thumbnail opposite).

- Modularity and Model code
- Wheel motor
- Shaft motor
- Valving systems and hydrobases
- Brake
- Options



Support types

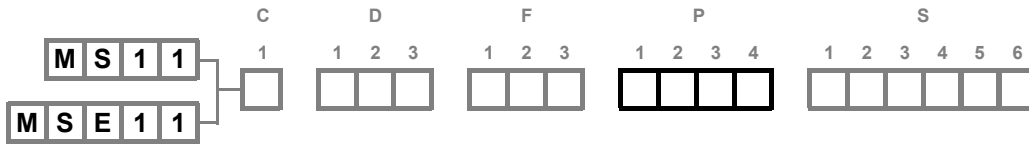

C	A mm [in]	B mm [in]	C mm [in]	D mm [in]	E mm [in]	N mm [in]	Wheel rim mountings	L mm [in]	
	Ø 175.7 [6.92 dia.]	Ø 225 [8.86 dia.]	Ø 276 [10.87 dia.]	218.6 [8.61]	Ø 291 [11.46 dia.]	Ø 24 [0.94 dia.]	5 x M22x1.5	14 [0.55]	
	Ø 175.7 [6.92 dia.]	Ø 225 [8.86 dia.]	Ø 276 [10.87 dia.]	218.6 [8.61]	Ø 291 [11.46 dia.]	Ø 22 [0.87 dia.]	10 x M20x1.5	14 [0.55]	
	Ø 160.7 [6.33 dia.]	Ø 205.0 [8.07 dia.]	Ø 250 [9.84 dia.]	174.4 [6.87]	Ø 289.5 [11.40 dia.]	Ø 20 [0.79 dia.]	12 x M18x1.5	15 [0.59]	
	Ø 175.7 [6.92 dia.]	Ø 225 [8.86 dia.]	Ø 276 [10.87 dia.]	219.6 [8.65]	Ø 291 [11.46 dia.]	Ø 22 [0.87 dia.]	10 x M20x1.5	21 [0.83]	
	Ø 220.7 [8.69 dia.]	Ø 275 [10.83 dia.]	Ø 314 [12.36 dia.]	218.6 [8.61]	Ø 291 [11.46 dia.]	Ø 22 [0.87 dia.]	8 x M20x1.5	14 [0.55]	



The supports in gray must not be assembled with an MSE hydrobase.

Studs

		P mm [in]	C min. mm [in]	C max. mm [in]	D mm [in]	Class
Various studs	M18 x 1.5	55 [2,17]	5 [0,20]	17 [0,67]	23 [0,91]	 12,9
	M20 x 1.5	60 [2,36]		14 [0,55]	25 [0,98]	
	M22 x 1.5	65 [2,56]		24 [0,94]	26 [1,02]	
Screws	M12					



You can accumulate more than one optional part. Consult your Poclair Hydraulics sales engineer.



Load curves

Permissible radial loads

Test conditions :

Static : 0 tr/min [0 RPM] 0 bar [0 PSI]

Dynamic : 0 tr/min [0 RPM], code 0 displacement, without axial load at max. torque

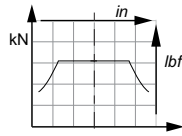

Service life of bearings

Test conditions :

L : Millions B10 revolutions at 150 bars (average pressure), with 25 cSt fluid, code 0 displacement, without axial load.

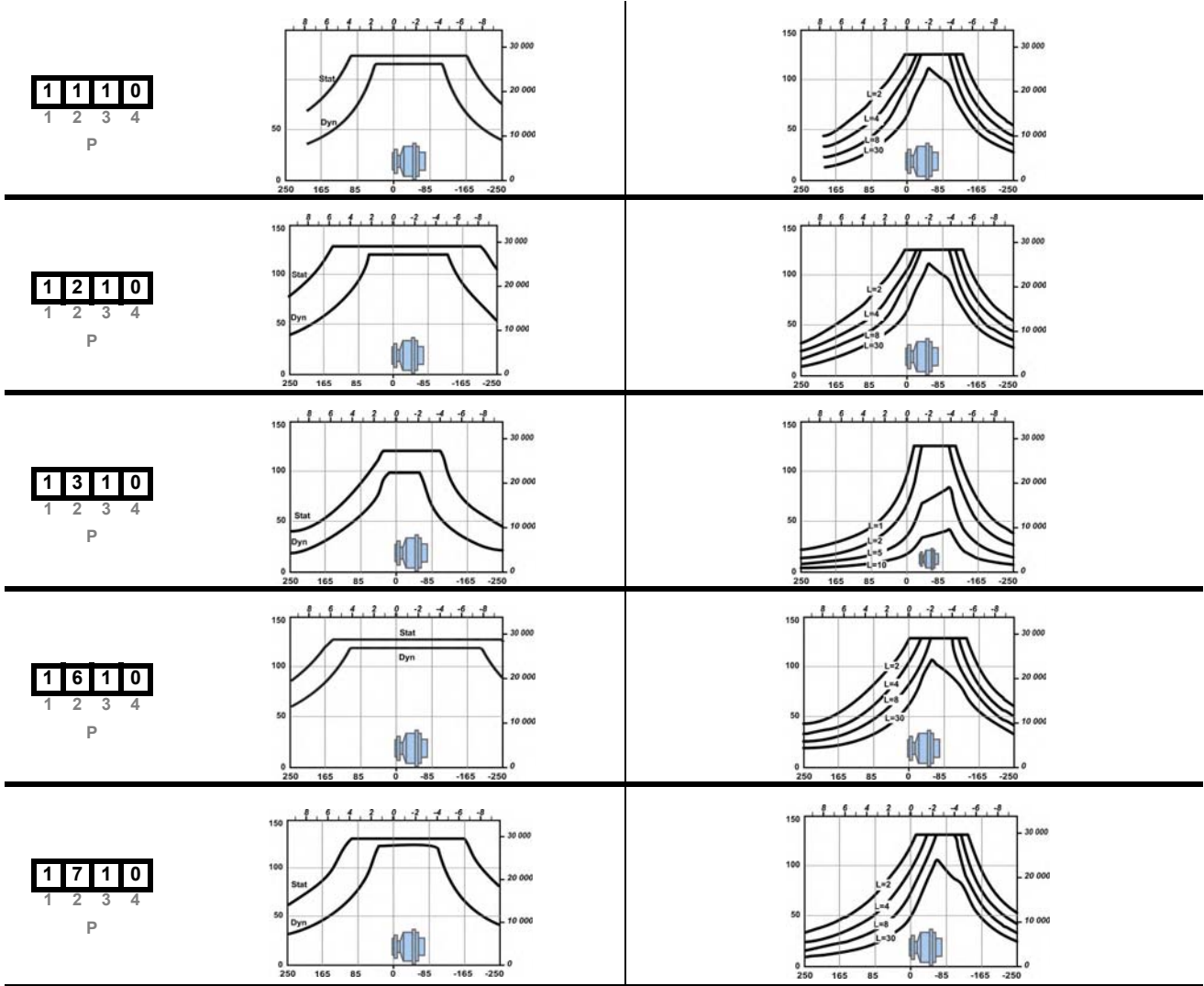

Modularity and Model code

Wheel motor

Shaft motor

Valving systems and hydrobases

Brake

Options



The service life of the components is influenced by the pressure. You must check that the combination of forces applied (Axial load / Radial load) is compatible with the permissible loads for the components, and that the resulting service lives of these components complies with the application's specifications. For an accurate calculation, consult your Poclain Hydraulics application engineer.

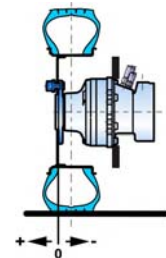



Support types (continued)

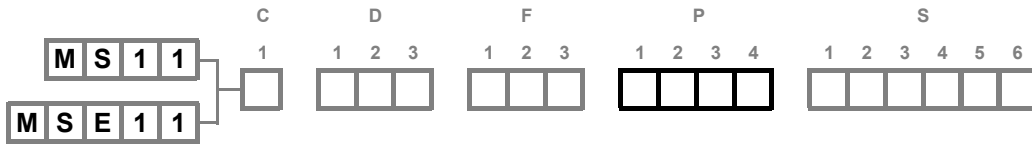

C	A m m [in]	B m m [in]	C m m [in]	D m m [in]	E m m [in]	N m m [in]	Wheel rim mountings	L m m [in]																					
<table border="1"> <tr><td>1</td><td>G</td><td>1</td><td>0</td></tr> <tr><td>1</td><td></td><td>2</td><td></td></tr> <tr><td></td><td></td><td>3</td><td></td></tr> <tr><td></td><td></td><td>4</td><td></td></tr> </table> <p style="text-align: center;">P</p>	1	G	1	0	1		2				3				4		Ø 175.7 [6.92 dia.]	Ø 225 [8.86 dia.]	Ø 270 [10.63 dia.]	284.6 [11.20]	Ø 291 [11.46 dia.]	Ø 24 [0.94 dia.]	10 x M22x1.5	16 [0.63]					
1	G	1	0																										
1		2																											
		3																											
		4																											
<table border="1"> <tr><td>1</td><td>Q</td><td>4</td><td>0</td></tr> <tr><td>1</td><td>P</td><td>4</td><td>0</td></tr> <tr><td>1</td><td></td><td>2</td><td></td></tr> <tr><td></td><td></td><td>3</td><td></td></tr> <tr><td></td><td></td><td>4</td><td></td></tr> </table> <p style="text-align: center;">P</p>	1	Q	4	0	1	P	4	0	1		2				3				4		Ø 175.7 [6.92 dia.]	Ø 225 [8.86 dia.]	Ø 354 [13.94 dia.]	294.6 [11.60]		Ø 24 [0.94 dia.]	10 x M22x1.5	39 [1.54]	
1	Q	4	0																										
1	P	4	0																										
1		2																											
		3																											
		4																											
<table border="1"> <tr><td>1</td><td>P</td><td>3</td><td>0</td></tr> <tr><td>1</td><td>Q</td><td>3</td><td>0</td></tr> <tr><td>1</td><td></td><td>2</td><td></td></tr> <tr><td></td><td></td><td>3</td><td></td></tr> <tr><td></td><td></td><td>4</td><td></td></tr> </table> <p style="text-align: center;">P</p>	1	P	3	0	1	Q	3	0	1		2				3				4		Ø 175.7 [6.92 dia.]	Ø 225 [8.86 dia.]	Ø 354 [13.94 dia.]	294.6 [11.60]		Ø 24 [0.94 dia.]	10 x M22x10	39 [1.54]	
1	P	3	0																										
1	Q	3	0																										
1		2																											
		3																											
		4																											

Also see "Brake" section (thumbnail opposite).

Also see "Brake" section (thumbnail opposite).



Load curves (continued)

Permissible radial loads

Test conditions :

Static : 0 tr/min [0 RPM] 0 bar [0 PSI]

Dynamic : 0 tr/min [0 RPM], code 0 displacement, without axial load at max. torque

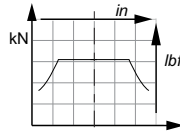

Service life of bearings

Test conditions :

L : Millions B10 revolutions at 150 bars (average pressure), with 25 cSt fluid, code 0 displacement, without axial load.

1	G	1	0
1	2	3	4

P

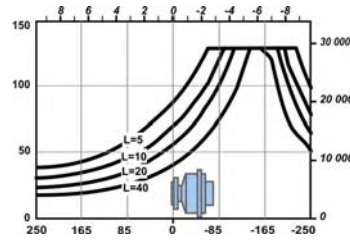
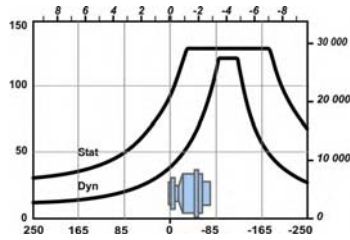

1	P	3	0
1	Q	3	0
1	P	4	0
1	Q	4	0
1	2	3	4

P

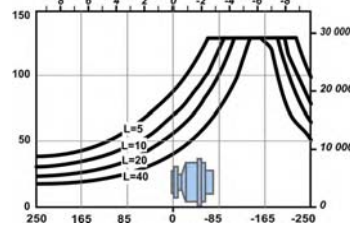
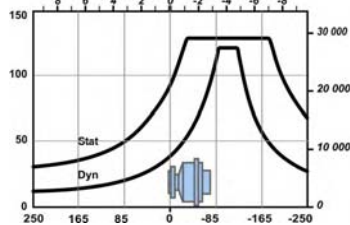

The service life of the components is influenced by the pressure. You must check that the combination of forces applied (Axial load / Radial load) is compatible with the permissible loads for the components, and that the resulting service lives of these components complies with the application's specifications. For an accurate calculation, consult your Poclain Hydraulics application engineer.

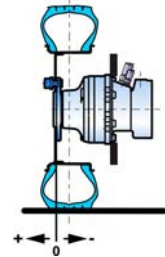

Modularity and Model code

Wheel motor

Shaft motor

Valving systems and hydrobases

Brake

Options





SHAFT MOTOR

Dimensions for standard (2A50) 1-displacement motor

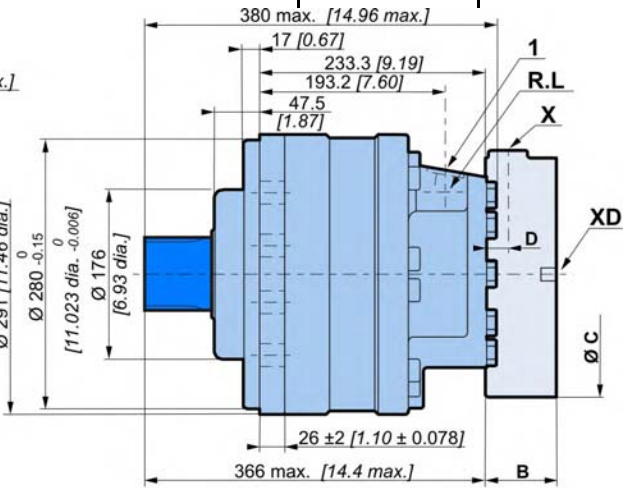
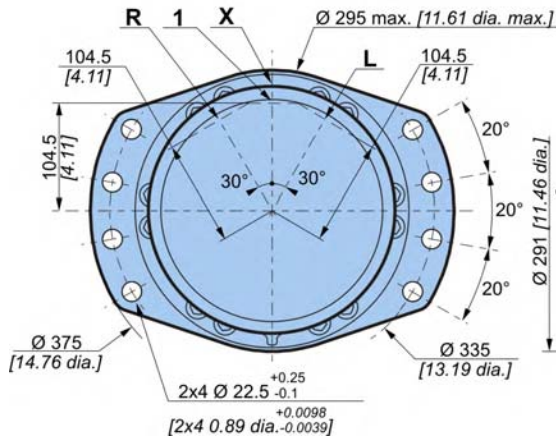

	88 kg [194 lb]	114 kg [251 lb]
	2 L [120 cu.in]	1.5 L [90 cu.in]

Dimensions for standard (2A50) 2-displacement motor

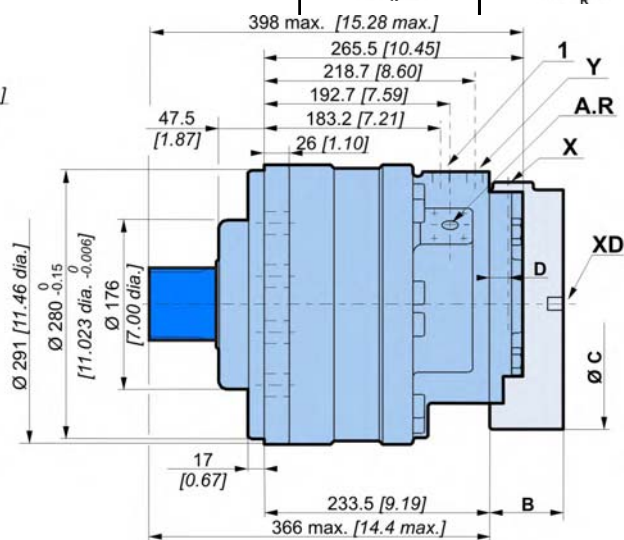
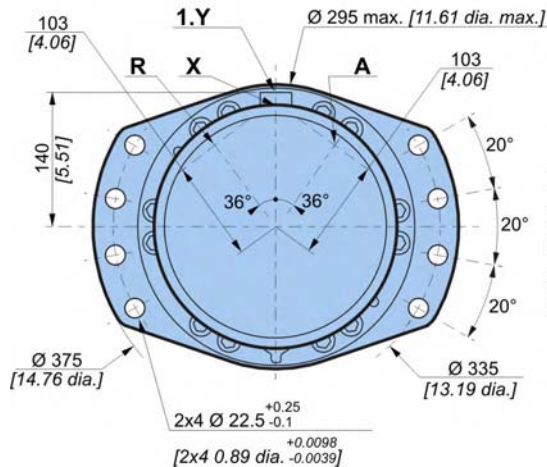

	88 kg [194 lb]	114 kg [251 lb]
	2 L [120 cu.in]	1.5 L [90 cu.in]

C	T12
B	92.5 [3.64]
C	Ø273.6 [10.77]
D	25.0 [0.96]



Also see 'Valving systems and hydrobases' section (thumbnail opposite).

Modularity and Model code

Wheel motor

Shaft motor

Valving systems and hydrobases

Brake

Options



Support types

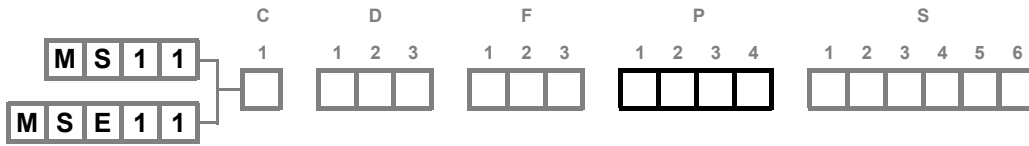

C		A	B	C	D	E	F	
DIN 5480 splines								
2 A 5 0 1 2 3 4 P	Nominal Ø	15	R 2.75	35	2 x M10	23	80	
	Module	[0.59]	[R 0.11]	[1.38]		[0.91]	[3.15]	
	Z							
NF E22-141 splines								
2 A 1 0 1 2 3 4 P	Nominal Ø	15	R 2.75	35	2 x M10	24	70	
	Module	[0.59]	[R 0.11]	[1.38]		[0.94]	[2.76]	
	Z							

Also see 'Valving systems and hydrobases' section (thumbnail opposite).

Splined coupling

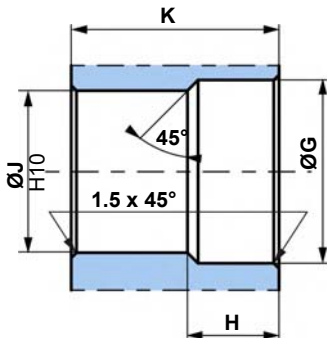

N : Nominal Ø.
Mo : Module.
Z : Number of teeth.

Standard DIN 5480
Pressure angle 30°.
Centering on flanks.
Slide fit (7H quality).

Standard NF E22-141
Pressure angle 20°.
Centering on flanks.
Slide fit (7H quality).

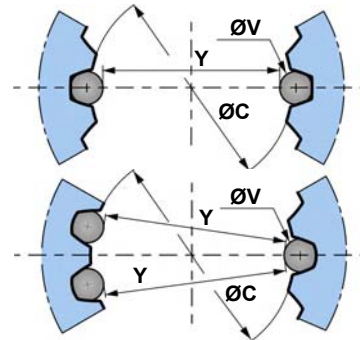

C	Ø G	H	Ø J	K	N	Mo	Z	Offset	Ø C (H10)	Ø V	Y	Tolerance µm [µin]
2 A 1 0 1 2 3 4 P	76 [2.99]	25 [0.98]	70 [2.76]	69 [2.72]	75 [2.95]	2.5	28	2 [0.08]	70 [2.76]	5 [0.20]	65.169 [2.57]	+ 103 / 0 [+4.055 / 0]
2 A 5 0 1 2 3 4 P	81.5 [3.21]	25 [0.98]	74 [2.91]	79 [3.11]	80 [3.15]	3	25	0.85 [0.0335]	74 [2.91]	5.25 [0.21]	68.957 [2.71]	+ 71 / 0 [+2.795 / 0]

General tolerances : ± 0.25 [±0.0098].

Material: Ex: 42CrMo4.

Hardening treatment to obtain R = 800 to 900 N/mm² [R = 116 030 to 130 533 PSI].



Load curves

Permissible radial loads

Max. permissible loads: 0 tr/min [0 RPM]; 0 bar [0 PSI]

Continuous permissible loads:
 > 0 tr/min [> 0 RPM]; 275 bar [3 988 PSI].

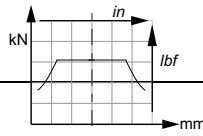

Service life of bearings

Test conditions :

L : Millions B10 revolutions at 150 bars (average pressure), with 25 cSt fluid, code 0 displacement, without axial load.

2 A 5 0
 1 2 3 4
 P

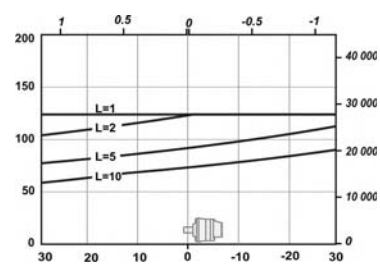
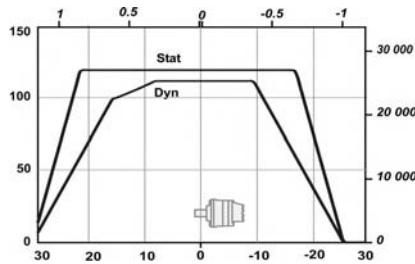

2 A 1 0
 1 2 3 4
 P

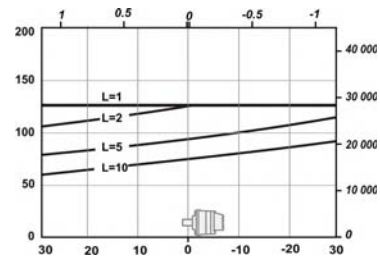
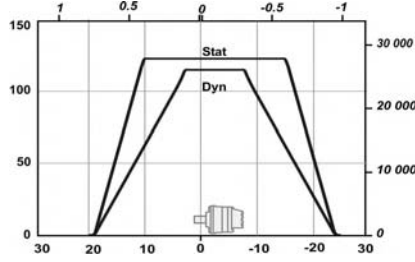

Modularity and Model code

Wheel motor

Shaft motor

Valving systems and hydrobases

Brake

Options



The service life of the components is influenced by the pressure. You must check that the combination of forces applied (Axial load / Radial load) is compatible with the permissible loads for the components, and that the resulting service lives of these components complies with the application's specifications. For an accurate calculation, consult your Poclain Hydraulics application engineer.

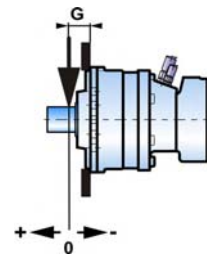

	G
2 A 1 0	96.75 [3.81]
2 A 5 0	101.25 [3.99]





VALVING SYSTEMS AND HYDROBASES

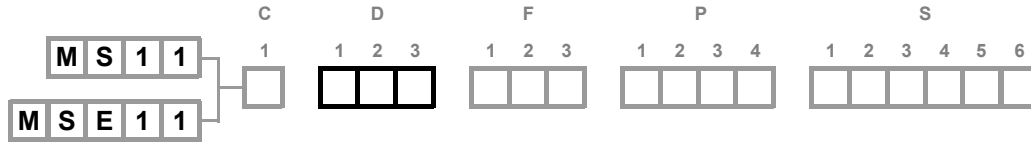

Dimensions for 1-displacement valving

1 1	44 kg [97 lb]	T 1 2	76.0 kg [167.2 lb]
1 2	48.9 kg [107.6 lb]		80.9 kg [178.0 lb]
0.75 L [45 cu.in]		0.92 L [55 cu.in]	

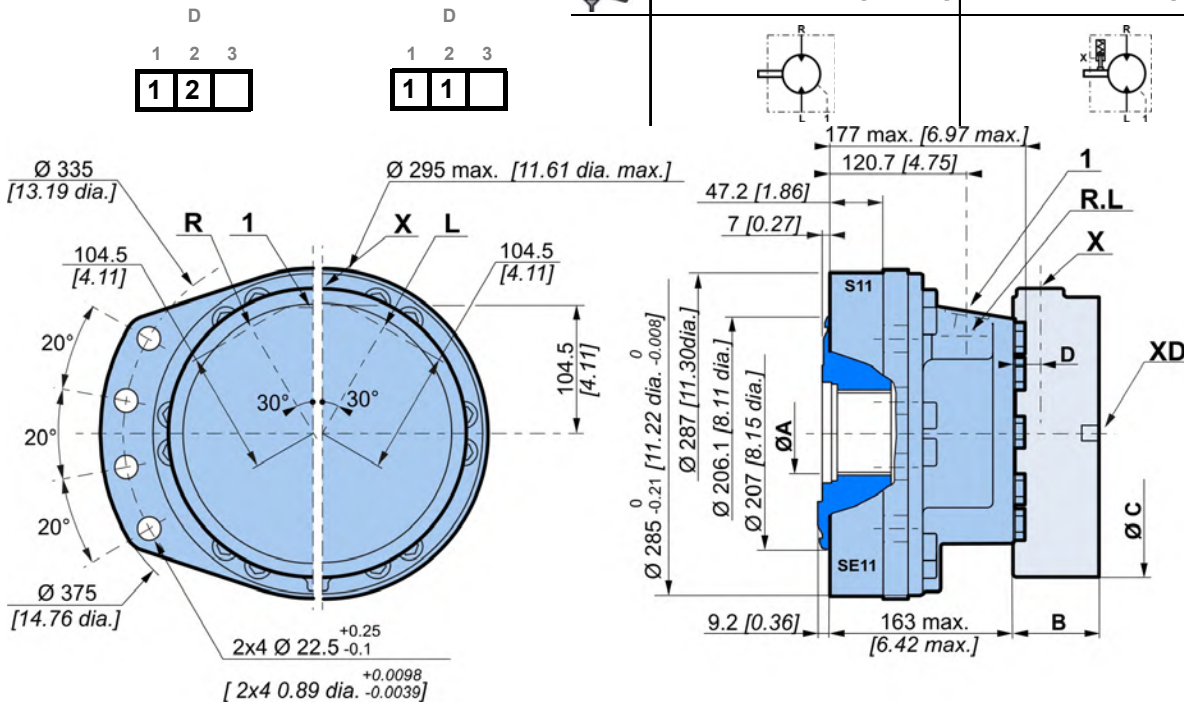

C	T12
B	92.5 [3.64]
C	Ø273.6 [10.77]
D	25.0 [0.96]

Cylinder block splines

(as per standard NF E22-141)

ØA	Module	z	Dimension on 2 pins	
			Y	ØV
75 [2.953]	2.5	28	65.169 [2.739]	5 [0.197]

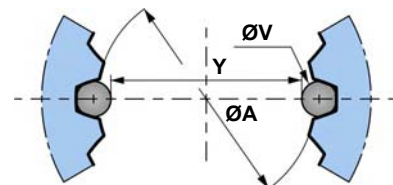

You are advised to have the installation validated by your Poclain Hydraulics application engineer before using the hydraulic unit in an application.



We must provide you with a detailed plan of the interface for any hydraulic unit use, consult your Poclain Hydraulics sales engineer.



Dimensions for 2-displacement valving

	2 1 44 kg [97 lb]	T 1 2 76.0 kg [167.2 lb]
	2 2 48.9 kg [107.6 lb]	80.9 kg [178.0 lb]
	0.75 L [45 cu.in]	0.92 L [55 cu.in]

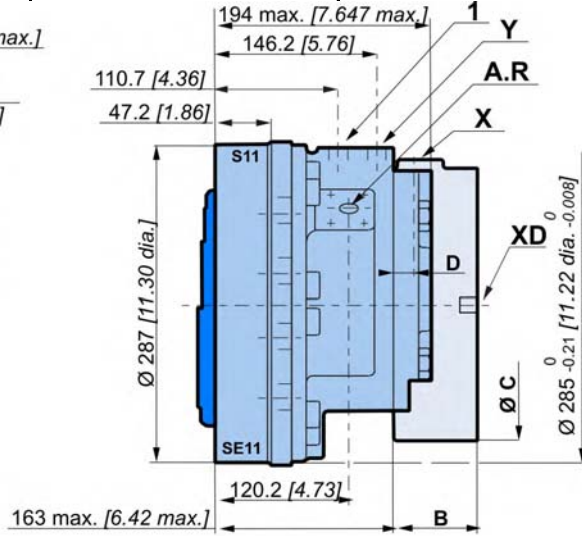
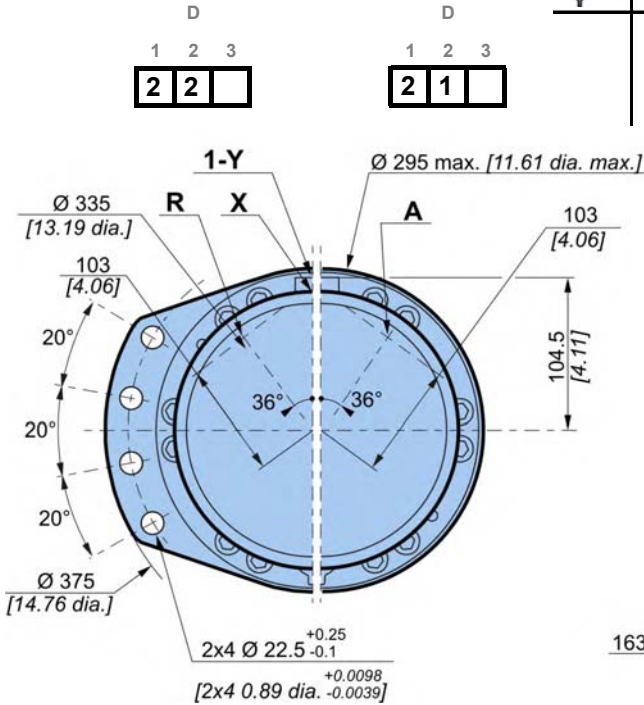

Dimensions for Twin-Lock™ valving

	2 E 48.9 kg [107.6 lb]	T 1 2 80.9 kg [178.0 lb]
	0.75 L [45 cu.in]	0.92 L [55 cu.in]

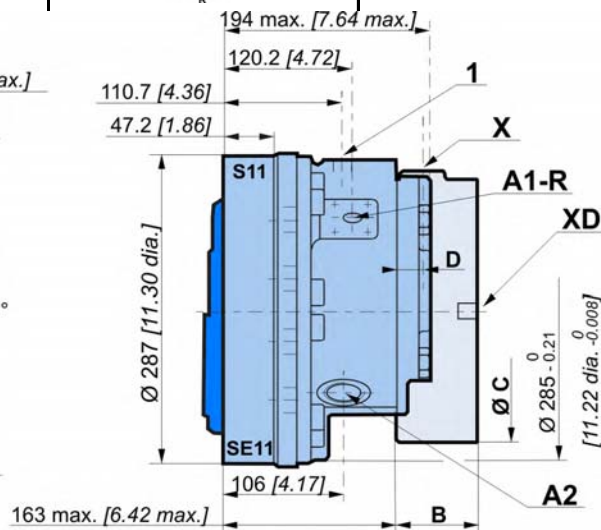
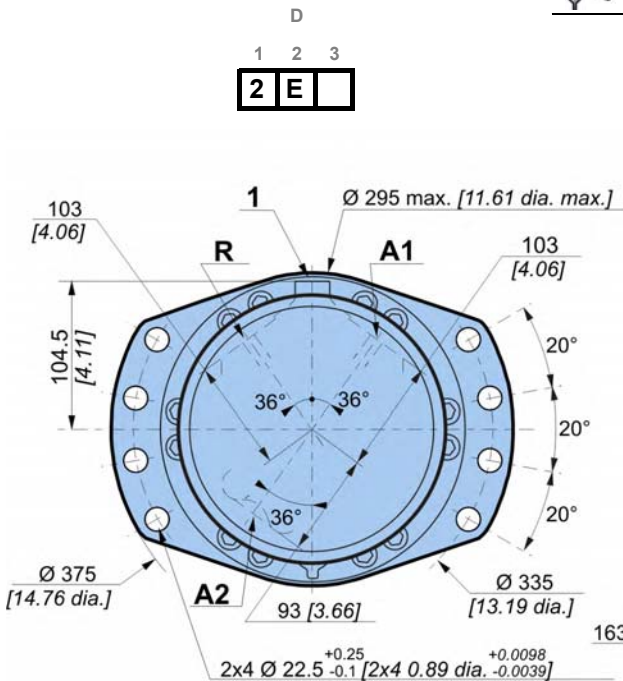

C	T12
B	92.5 [3.64]
C	Ø273.6 [10.77]
D	25.0 [0.96]



Dimensions for 1-displacement valving with built-in exchange

	1 5	44 kg [97 lb]	T 1 2	76.0 kg [167.2 lb]
	1 4	48.9 kg [107.6 lb]		80.9 kg [178.0 lb]
		0.75 L [45 cu.in]		0.92 L [55 cu.in]

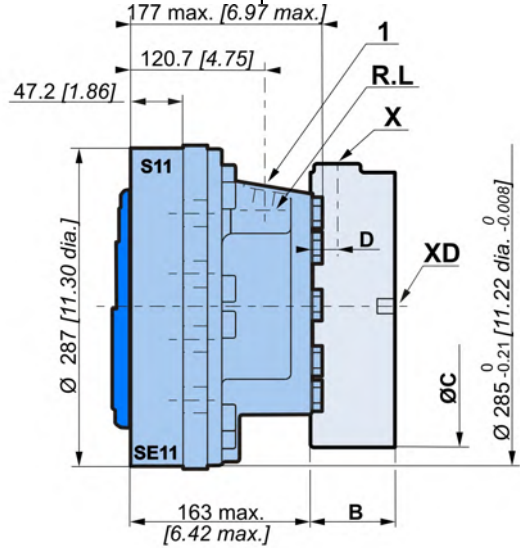
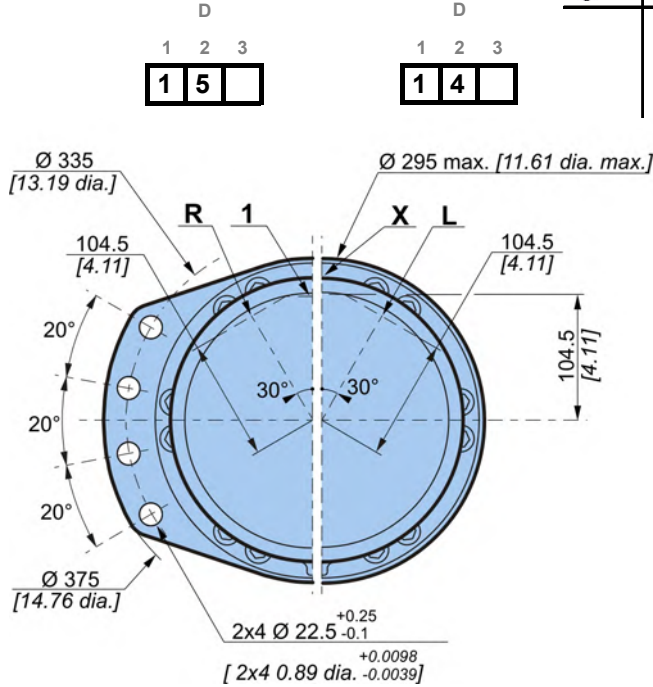

Dimensions for 2-displacement valving with built-in exchange

	1 5	44 kg [97 lb]	T 1 2	76.0 kg [167.2 lb]
	1 4	48.9 kg [107.6 lb]		80.9 kg [178.0 lb]
		0.75 L [45 cu.in]		0.92 L [55 cu.in]

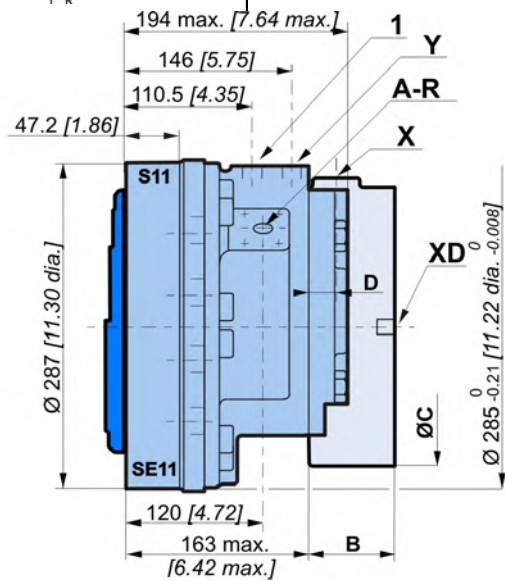
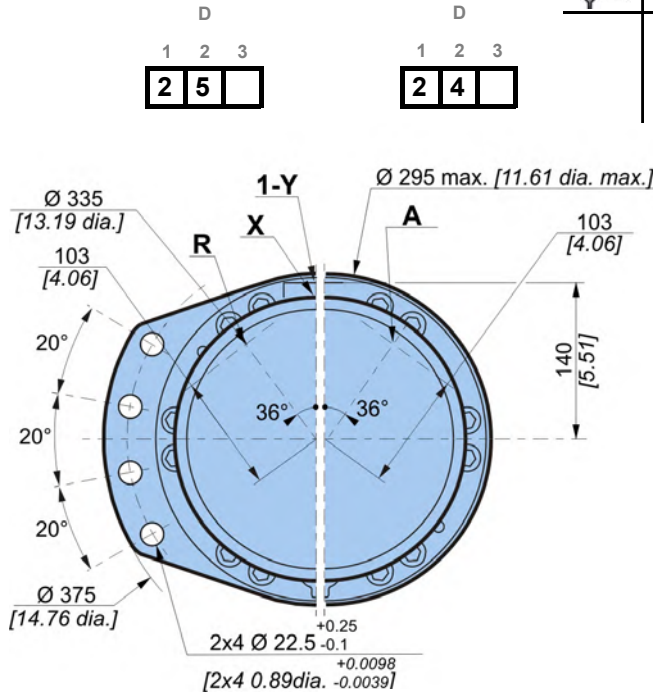

C	T12
B	92.5 [3.64]
C	Ø273.6 [10.77]
D	25.0 [0.96]

Modularity and Model code

Wheel motor

Shaft motor

Valving systems and hydrobases

Brake

Options



Dimensions for 2-displacement valving or Twin-Lock™ valving



48.9 kg [107.6 lb]

T 1 2

80.9 kg [178.0 lb]



0.75 L [45 cu.in]

0.92 L [55 cu.in]

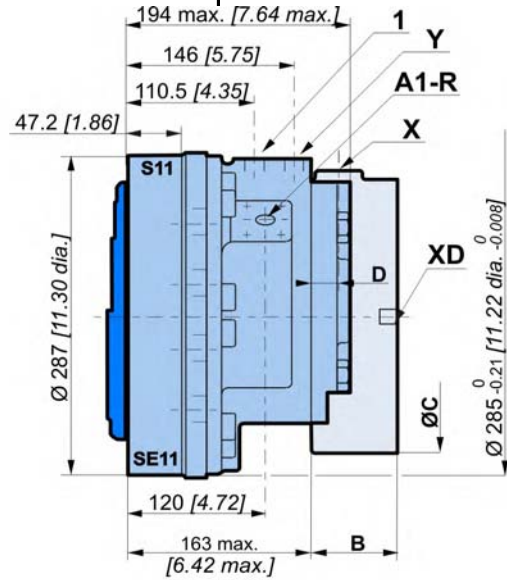
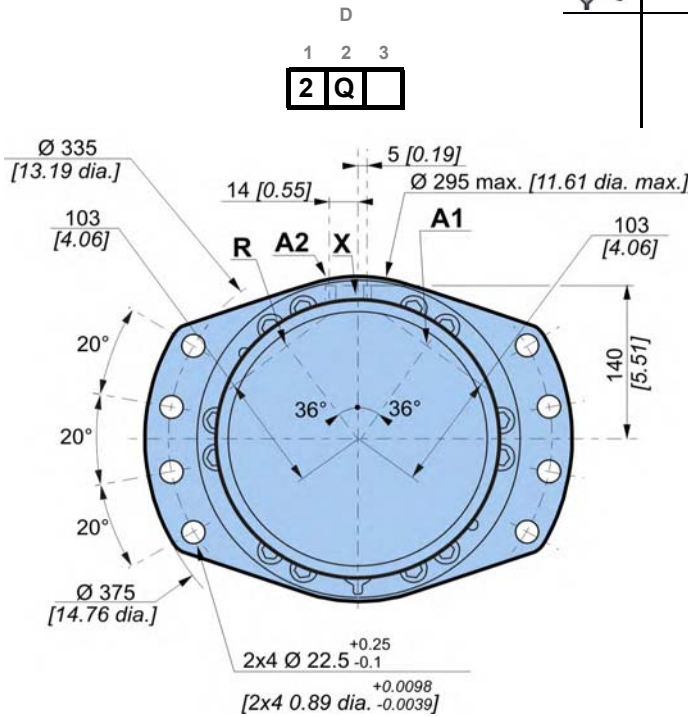
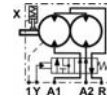
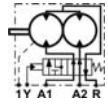

Exchange

When a coding request is made, you must specify information on the threshold of the selector and the valve.

Selector spool

Selector threshold bar [PSI]	Opening pressure of selector bar [PSI]
8 [116]	9.9 ±1.2 [144 ±17]

Fitted valve

P1 bar [PSI]	Q2 L/min [GPM]	P2 bar [PSI]
13.5 [195]	14 [3.7]	16 [232]
18 [261]	15 [3.9]	21 [305]
22 [319]	16 [4.2]	25 [363]

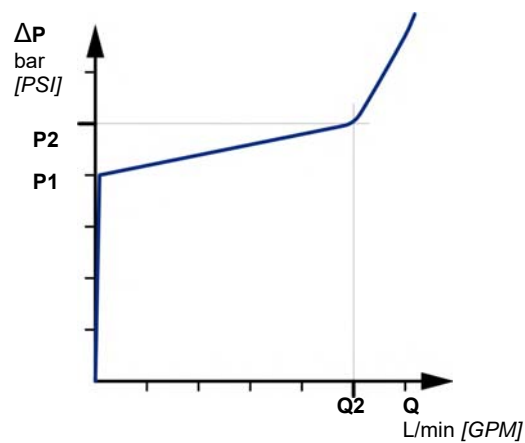



Chassis mountings

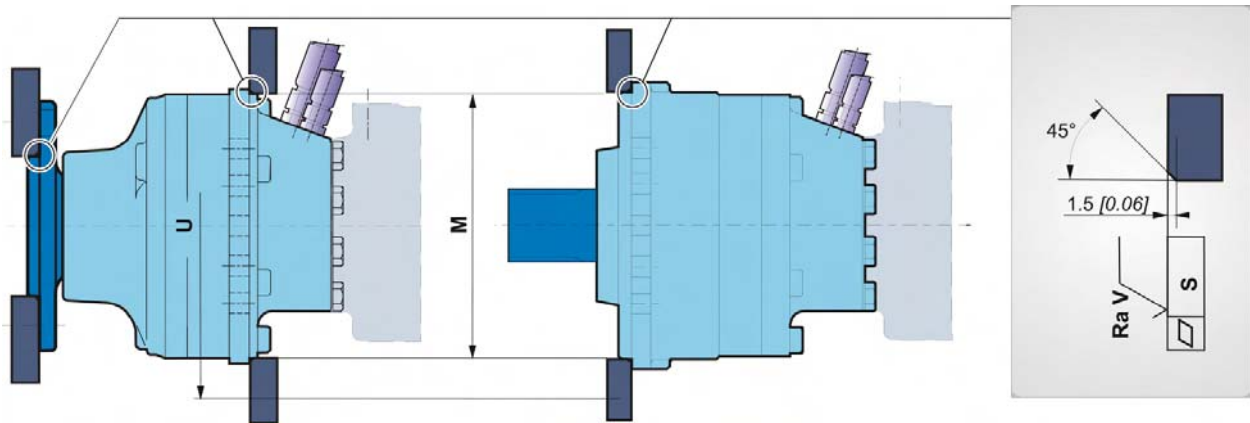

Take care over the immediate environment of the connections.

	ØM ⁽¹⁾	ØU	S	Ra V		Class
Wheel motor	285 [11,22]	335 [13,19]	0,2	12,5µm	2 x 4	8,8
Shaft motor	280 [11,02]	335 [13,19]	[0,008]	[0,49µin]	4 x M20	

(1) +0,3 [+0,012]
+0,2 [+0,008]

Modularity and Model code

Wheel motor

Shaft motor

Valving systems and hydrobases

Brake

Options



Hydraulic connections

		Old standards	Standards	Power supply		Case drain	2 nd displacement control	Control of parking brake	Control of drum brake		
				R-L		1, 2		X	XT		
1 displacement	A	SAE J514	ISO 11926-1	1" 1/16"-12 UNF		3/4"-16 UNF		9/16"-18 UNF			
	1	ISO 6162 DIN 3852	ISO 6162 ISO 9974-1	DN9 PN400		M 16x15		M 16x15			
	2	ISO 6162 BSP	ISO 6162 ISO 1179-1	DN9 PN400		Ø21 [1/2" dia.]		Ø17 [3/8" dia.]			
	3	BSP	ISO 1179-1	Ø27 [3/4" dia.]		Ø21 [1/2" dia.]		Ø17 [3/8" dia.]			
	4	NF E48 050	ISO 9974-1	M27x2		M 16x15		M 16x15			
	5	DIN 3852	ISO 9974-1	M33x2		M 16x15		M 16x15			
	7	ISO 6162 SAE J514	ISO 6162 ISO 11926-1	DN9 PN400		3/4"-16 UNF		9/16"-18 UNF			
				R-A		1, 2	Y	X			
2 Displacement	A	SAE J514	ISO 11926-1	1" 1/16"-12 UNF		3/4"-16 UNF	9/16"-18 UNF	9/16"-18 UNF			
	1	ISO 6162 DIN 3852	ISO 6162 ISO 9974-1	DN13 PN400		M 16x15	M 16x15	M 16x15			
	2	ISO 6162 BSP	ISO 6162 ISO 1179-1	DN13 PN400		Ø21 [1/2" dia.]	Ø17 [3/8" dia.]	Ø17 [3/8" dia.]			
	3	BSP	ISO 1179-1	Ø27 [3/4" dia.]		Ø21 [1/2" dia.]	Ø17 [3/8" dia.]	Ø17 [3/8" dia.]			
				R-A1		A2	1, 2	Y	X		
Twin-Lock™	A	SAE J514	ISO 11926-1	1" 1/16"-12 UNF		9/16"-18 UNF	3/4"-16 UNF	9/16"-18 UNF	9/16"-18 UNF		
	1	ISO 6162 DIN 3852	ISO 6162 ISO 9974-1	DN13 PN400		M27x2	M 16x15	M 16x15	M 16x15		
	4	NF E48 050	ISO 9974-1	M27x2		M27x2 M22x15	M 16x15	M 16x15	M 16x15		
				ISO 9974-1					M 10x1 M 14x15		
Max. pressures		MS MSE bar [PSI]		450 [6,527]	450 [6,527]	400 [5,802]	400 [5,802]	1 [15]	30 [435]	30 [435]	20 [1740]



To find the connections' tightening torques, see the brochure "Installation guide" N° B61352L.



You are strongly advised to use the fluids specified in brochure "Installation guide" N° B61352L.



Do not put either a check valve or a poppet valve on the pilot lines (parking brake and displacement change) between the charge pump and the pilot valve. Do not use a piloting valve with integrated check valve.



Efficiency

Overall efficiency

Average values given for guidance for code 0 displacement after 100 hours of operation with HV46 hydraulic fluid at 50°C [122°F].

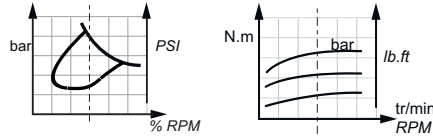

Actual output torque

MS11

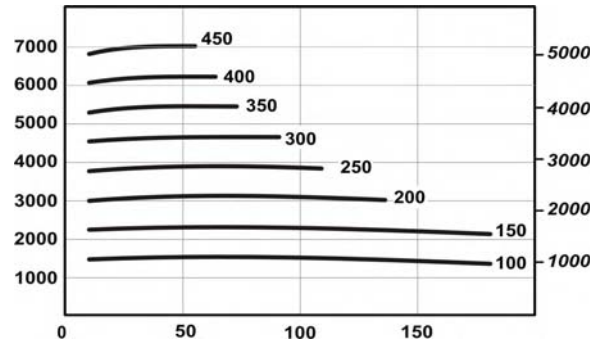
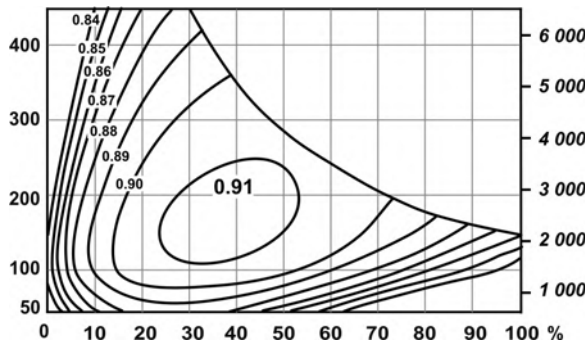

MSE11

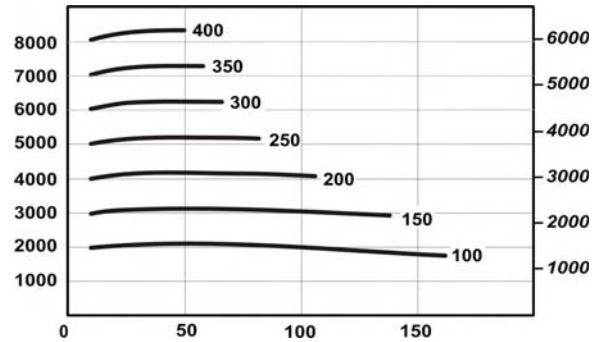
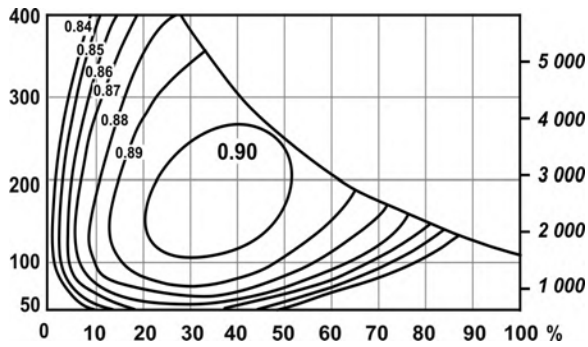

For a precise calculation, consult your Poclain Hydraulics application engineer.

Modularity and Model code

Wheel motor

Shaft motor

Valving systems and hydrobases

Brake

Options





BRAKES

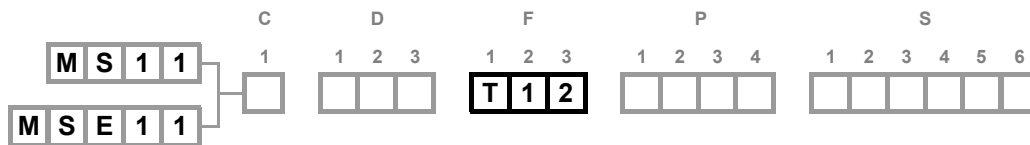

Rear brake

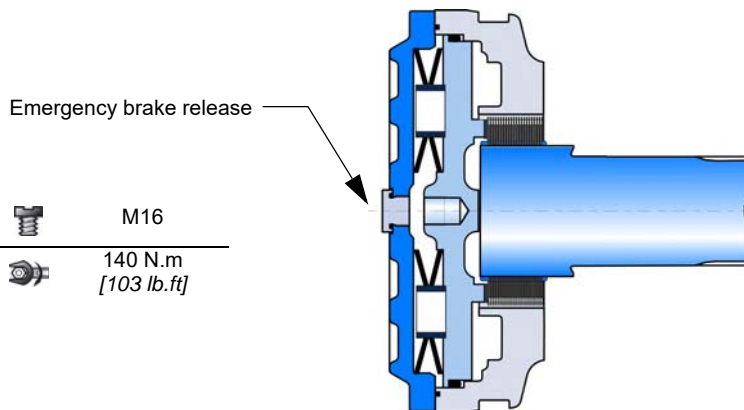

Brake principle

This is a multidisc brake which is activated by a lack of pressure. The spring exerts a force on the piston, which presses on the fixed and mobile discs, and immobilizes the shaft. The braking torque decreases in linear proportion to the brake release pressure.

C **T 1 2**

Parking brake torque at 0 bars on housing (new brake)	11,840 Nm [8,730 lb.ft]
Dynamic emergency braking torque at 0 bars on housing (max. 10 uses of emergency brakes)	7,695 Nm [5,680 lb.ft]
Residual parking braking at 0 bars on housing *	8,880 Nm [6,550 lb.ft]
Min. brake release pressure	12 bar [174 PSI]
Max. brake release pressure	30 bar [435 PSI]
Oil capacity	170 cm ³ [10.4 cu.in]
Volume for brake release	40 cm ³ [2.4 cu.in]
Max. energy dissipation	123 699 J

* After emergency brake has been used



Do not run-in the multidisc brakes.



A functional check of the parking brake must be carried out each time it is used as an auxiliary brake (or emergency brake). For all vehicles capable of speeds over 25 km/h, please contact your Poclair Hydraulics application engineer.

Modularity and Model code

Wheel motor

Shaft motor

Valving systems and hydrobases

Brake

Options



Drum brake (315 x 80)

Diameter of brake pads : Ø 315 [12.4 dia.]
 Width of friction surface : 80 [3.15]

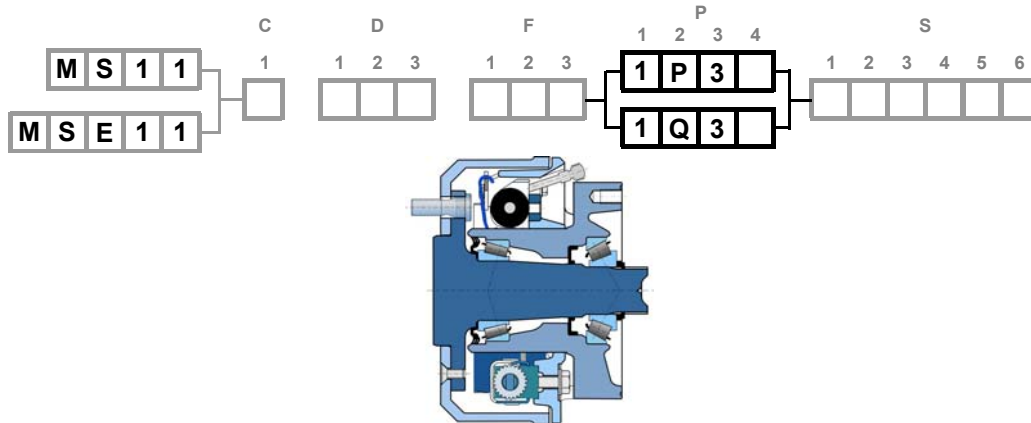

Brake pads	315 x 80		C
Asbestos free material	BERAL 1518		
Compensation for wear	Automatic		
Hydraulically controlled dynamic braking			
Max. permissible continuous brake torque	7,200 N.m [5,310 lb.ft]		
Pressure to obtain max. permissible continuous brake torque	71 bar [1,023 PSI]		
Max. permissible brake torque	12,000 N.m [8,851 lb.ft]		
Pressure to obtain max. permissible brake torque	120 bar [1,740 PSI]		
Brake cylinder filler hole			
Size	M14 x 1.5	M10 x 1	
Standard	DIN 74234	DIN 74234	
Fluid			
Mineral	Yes	Yes	P
DOT 3/DOT4/SAE J1703	No	Yes	Q
Max. volume required to bring pads into contact	5.38 cm ³ [0.33 cu.in]	5.38 cm ³ [0.33 cu.in]	
Mechanically controlled parking brake			
Max. braking torque	12,000 N.m [8,851 lb.ft]		
Max permissible force on the cable	3,800 N [854 lbf]		
Force required to bring pads into contact	63.5 N [14.3 lbf]		
Stroke required to bring pads into contact	A	10.5 mm [0.41 "]	B
	B	12 mm [0.47 "]	
Max. stroke before automatic brake adjustment	A	12.5 mm [0.49 "]	Cable
	B	14.5 mm [0.57 "]	

End view of shaft

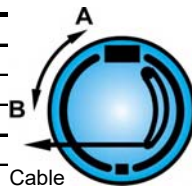

To validate the drum brake, it is necessary to carry out sufficient vehicle tests under real operation conditions, especially to confirm the brake response, the noise and thermal behavior of the brakes. The responsibility for the suitability of the brake is assigned to the vehicle manufacturer.



The max. braking torque can only be obtained when the brake has been run in. Consult your Poclain Hydraulics application engineer.

Control

The drum brakes can be controlled hydraulically (service brake) and by a cable (mechanical control for parking brake).



Do not use hydraulic and mechanical brake controls simultaneously.



Brake release pressure vented.



When making an encoding request, you must indicate the following information:

- The material of the brake linings,
- The type of connection at the end of the parking brake control cable,
- Fill out the technical questionnaire for validation of the brake.



OPTIONS

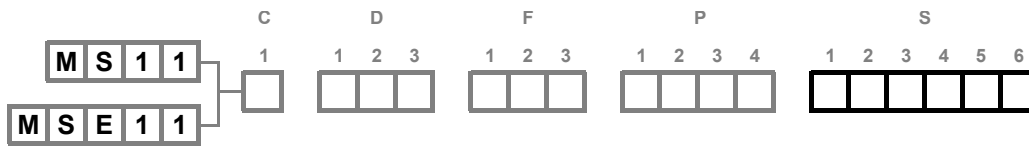

You can accumulate more than one optional part. Consult your Poclain Hydraulics sales engineer.

1 - Fluorinated elastomer seals

Nitrile seals marked in the figure below replaced by fluorinated elastomer seals.

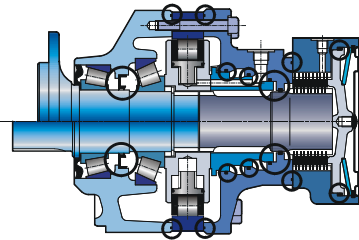

Consult your Poclain Hydraulics sales engineer.

2 - S - Q - 8 - Installed speed sensor or predisposition

Designation

T4 speed sensor (without rotation direction)	2
TR speed sensor (digital rotation direction)	S
TD speed sensor (two phase shifted frequencies)	Q
Predisposition for speed sensor	8

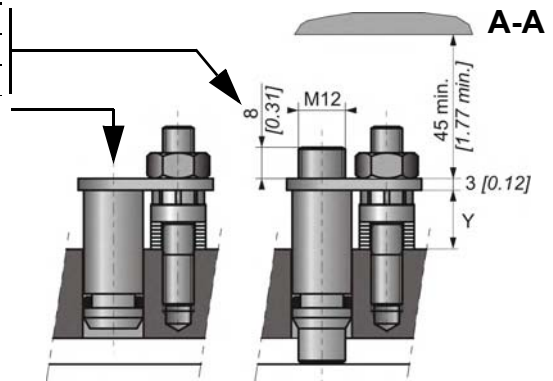
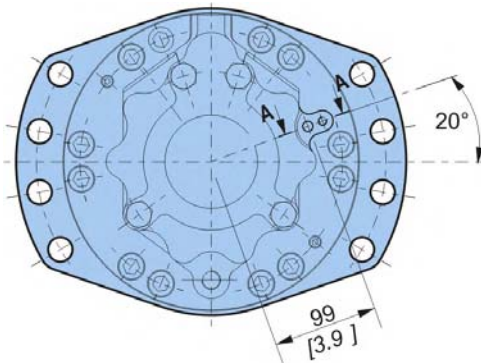

Max. length Y= 20.9
Standard number of pulses per revolution= 56



Look at the "Mobile Electronic" N° A01889D technical catalogue for the sensor specifications and its connection.



To install the sensor, see the "Installation guide" brochure No. B61352L.

Modularity and Model code

Wheel motor

Shaft motor

Valving systems and hydrobases

Brake

Options



3 - Brake environmental cover without plug

No plug or hole in the cover.

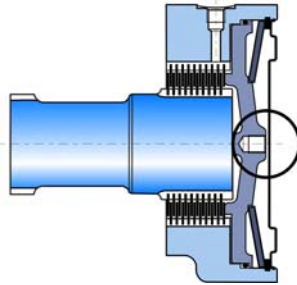

5 - Drainage

Additional drain in the cover.

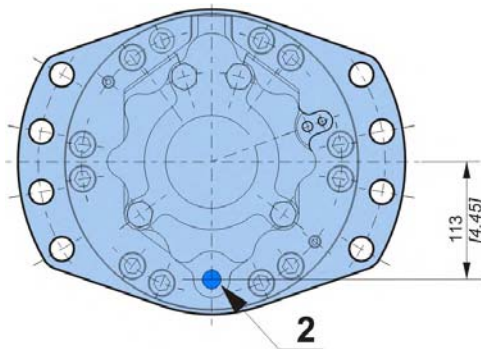

7 - Diamond™

Special treatment of the motor core which considerably increases its strength, making the motor much more tolerant to temporary instances of the operating conditions being exceeded.

9 - Double-centering valving cover

This option allows a motor to be installed from the front or the back.

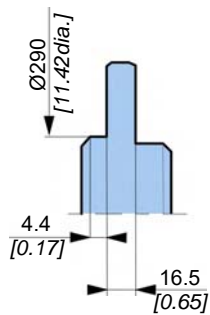



A - Hollow shaft

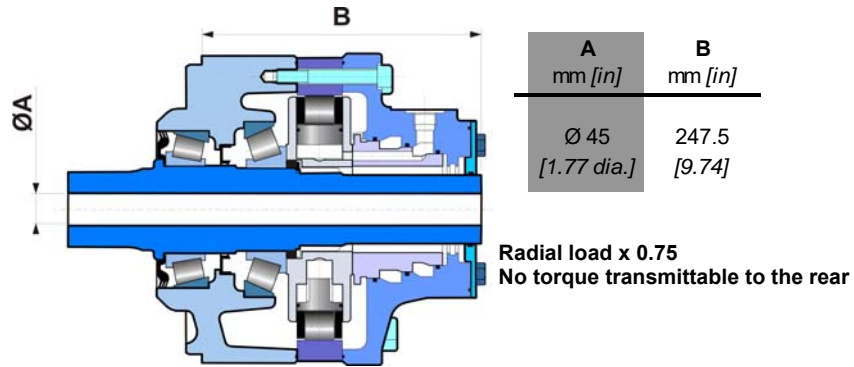

B - Drain on the bearing support

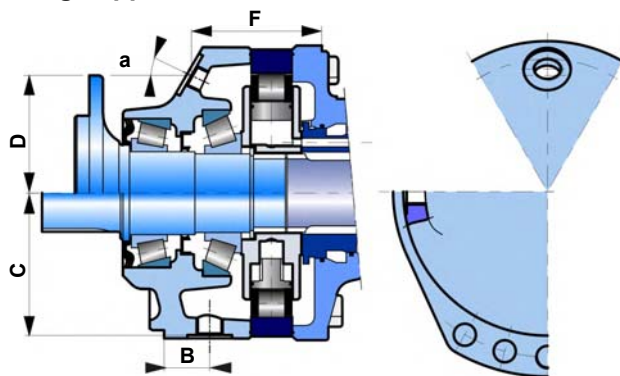

	ISO	B	C	D	F	a
		mm [in]	mm [in]	mm [in]	mm [in]	
Shaft motor	M18 x 1.5	32.5 [1.28]	143 [5.63]			
Wheel motor	M18 x 1.5			112 [4.41]	112.5 [4.43]	30°

C - Abrasive environments (mechanical seal)

Certain environments can be very harmful. The mirror seal gives reinforced motor sealing.



Consult your Poclain Hydraulics sales engineer.

E - Reinforced sealing

Requires reinforced seals and, for an unbraked motor, a rear reinforced plate (R08 - 8 [0.314] thick, instead of 4 [0.157]).

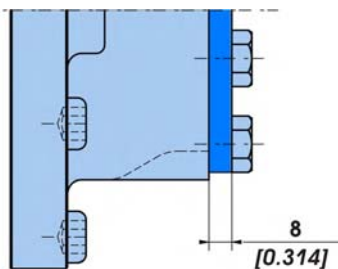
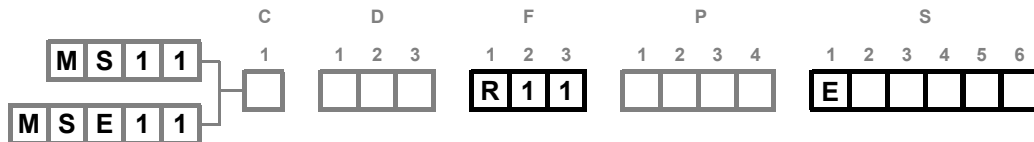

Modularity and Model code

Wheel motor

Shaft motor

Valving systems and hydrobases

Brake

Options



G - Special wheel rim mounting

Enables certain combinations different from the standard mountings defined on pages 11 and 13.



Consult your Poclain Hydraulics sales engineer.

H - High efficiency

Reinforced piston sealing to improve volumetric efficiency.



For a precise calculation, consult your Poclain Hydraulics application engineer.

J - Treated shaft

Heat treatment on the indicated bearing radius and splines.

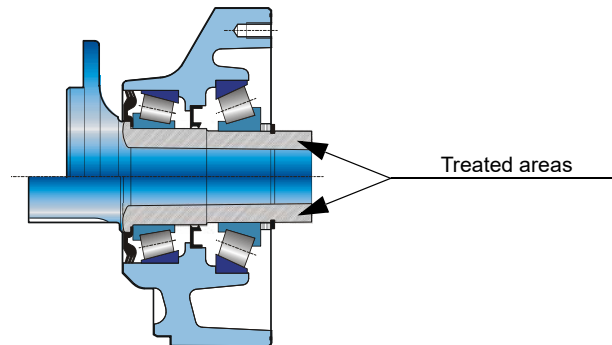

M - High speed

Under certain conditions, an increase in the maximum speed of 30% above the values indicated in the table on page 2 is possible.



For a precise calculation, consult your Poclain Hydraulics application engineer.

T - Soft Shift™

Progressive displacement change (cushioned slide-valve)

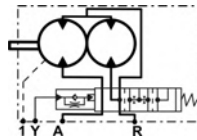

Consult your Poclain Hydraulics sales engineer.



Modularity and Model code

Wheel motor

Shaft motor

Valving systems and hydrobases

Brake

Options





Modularity and
Model code

Wheel motor

Shaft motor

Valving systems
and hydrobases

Brake

Options



Poclain Hydraulics reserves the right to make any modifications it deems necessary to the products described in this document without prior notification. The information contained in this document must be confirmed by Poclain Hydraulics before any order is submitted.

Illustrations are not binding.

The Poclain Hydraulics brand is the property of Poclain Hydraulics S.A.

-  07/10/2021
-  801 478 120C
-  801 478 190D
-  801 578 103E
-  801 578 115S
-  801 578 127F
-  A07443Q
-  Non available
-  A14242F

