



BREVINI[®]

Motion Systems

P.T.O. GEARBOXES

Technical Catalogue

January
2018

web edition

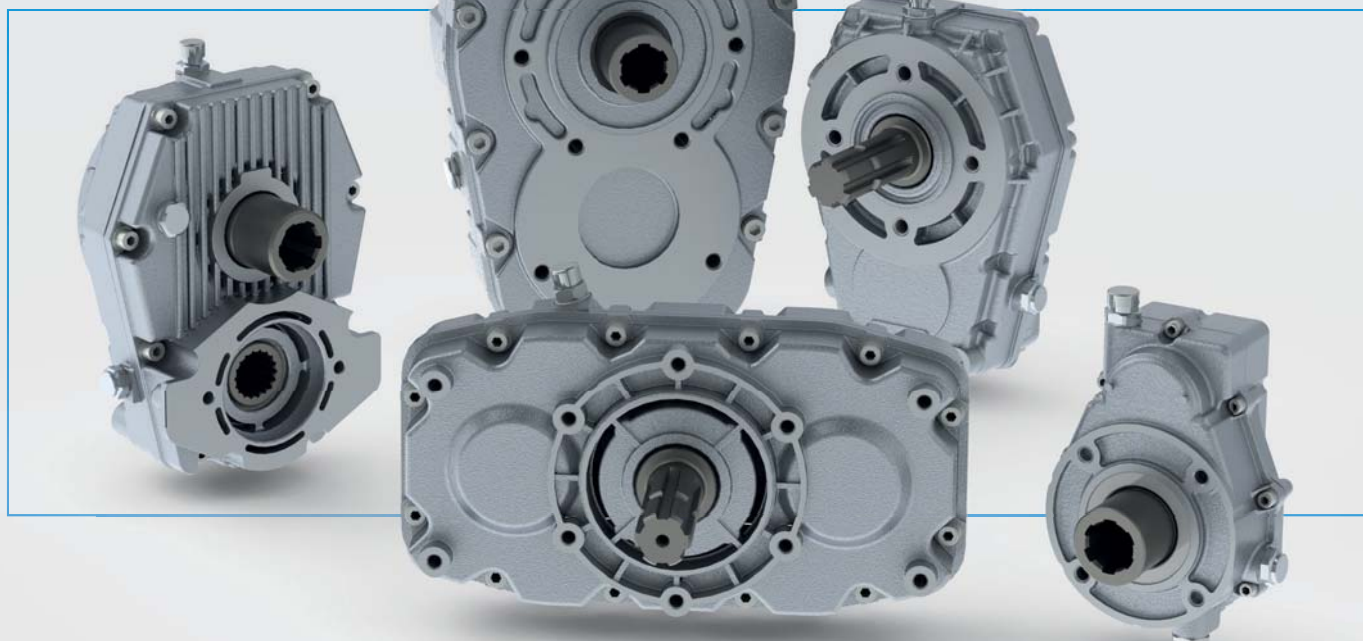

GENERAL FEATURES

This catalog shows the characteristics of the gearboxes (speed increasers) ML and B series, and gearboxes (speed reducers) RD. Gearboxes are generally used for the connection of hydraulic pump with low speed tractor power take-off.

Calculation for gears was done according to UNI ISO 6336.
Calculation for bearing was done according to ISO 281.

Operating temperature is between -20 °C to + 85 °C.

Materials used for the components of gear have been chosen according to the study of different requirements of resistance to stress and wear. In particular, the gears are made of hardened steel for high endurance. Housing and cover can be made both in aluminum alloy or cast iron, depending on the required code.

Assembly of gearbox must be performed referring to the position of the level indicator, oil drain and vent/fill plug.

Gearboxes have different attachment points that allow an integral attachment to the equipment or machine.

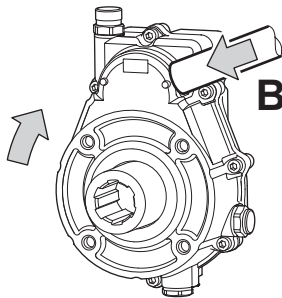

If it is not possible, gearboxes should be bound with a torque arm "B" (see figure). To avoid abnormal stress to the system, the torque arm "B" must be placed as close as possible to the mounting plane (PTO side) of gearbox.

Determination of the average duration of the gear

The duration of the gearboxes depends on the working conditions and the torques transmitted.

In the technical specifications of each gearbox is shown a graph that allows to verify their duration (in hours) as a function of transmitted average torque.

Graphs are output of standard calculations, they do not represent output of experimental tests, however they are a useful tool, as shown by experience achieved by our company in design and manufacture of gearboxes.

In the gearbox technical data table, we have 2 torque values.

Maximum starting torque (C_1) and **maximum torque for continuous duty (C_2)**.

If gearbox works with torque values that do not exceed C_2 , the average torque C_m corresponds to value C_2 and duration of the gear is about 3500 hours. In mixed duty cycles, the transmitted torque can reach the limits of the maximum starting torque (C_1).

A typical example of mixed duty cycle is shown in the following diagram:

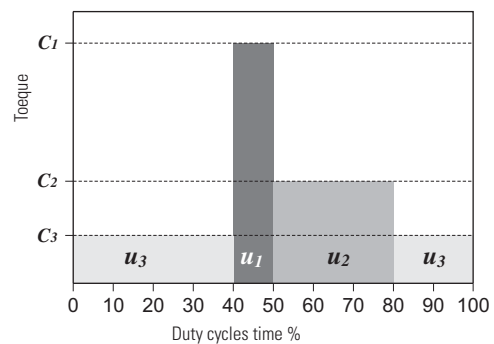

- 10% of the total time (u_1) - C_1 torque;
- 30% of the total time (u_2) - C_2 torque;
- 60% of the total time (u_3) - C_3 torque.

In a mixed duty cycle the value of the average torque (C_m) can be calculated with a formula that takes into account the torques transmitted with different duty cycles (as required by standard).

$$C_m = \sqrt[3]{\frac{C_1^3 \cdot u_1 + C_2^3 \cdot u_2 + C_{..}^3 \cdot u_{..}}{(u_1 + u_2 + u_{..})}}$$

Where:

- C_m = average torque (pump side);
- C_1 = maximum starting torque (pump side);
- C_2 = Maximum torque for continuous duty (pump side)
- $C_{..}$ = .. more torque (pump side)

- u_1 = % duty cycle - C_1 torque
- u_2 = % duty cycle - C_2 torque
- $u_{..}$ = % duty cycles - $C_{..}$ torque

GENERAL FEATURES

Example of calculation of gearboxes duration:

Speed increaser ML32 - transmission ratio 1: 2.5 - rpm 1000

Operating torque:: Duty cycles:
*C*1 = 100 Nm *u*1 = 10%
*C*2 = 65 Nm *u*2 = 30%
*C*3 = 40 Nm *u*3 = 60%

$$C_m = \sqrt[3]{\frac{100^3 \cdot 10 + 65^3 \cdot 30 + 40^3 \cdot 60}{10 + 30 + 60}} = 60.4 \text{ Nm}$$

Input rpm	Output (transmission ratio)						
	1:1,5	1:2	1:2,5	1:3	1:3,5	1:3,8	
540	curve	1	3	5	6	8	8
	rpm	810	1080	1350	1680	1836	2052
1000	curve	2	4	7	—	—	—
	rpm	1500	2000	2500	—	—	—

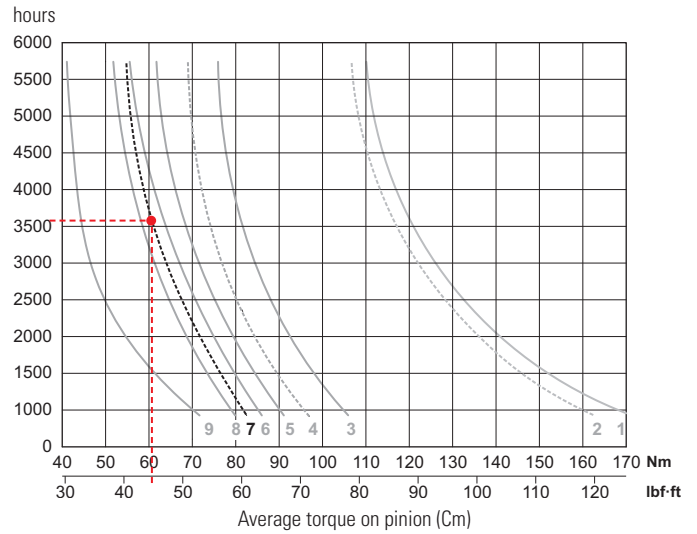

In diagram curve number **7** has to be considered (gear ratio **1: 2.5** at **1000 rpm**). The estimated duration of the average torque of **60.4 Nm** is approximately **3600 hours**.

Lubricating oil

The types of oil, in the following table, are those suggested for the correct lubrication of the gears and are differentiated according to the temperature at which gearboxes have to work.

For high torque, we recommend the use of oil type "EP (extreme pressure)".

For features that are outside the range of proposed values, please contact our sales department.

LUBRICATING OIL IN FUNCTION OF THE SEASONAL TEMPERATURE							
100	150	220	320	Industrial oils (according to ISO 3498 class CKC 220 viscosity according to ISO 3448)			
80 W	85 W	90	140	Oils for transmissions and differentials (according to SAE J 183 viscosity according to SAE J 300)			
30	40	50	60	Engine Oils (according to SAE J 308 class API GL / GL-5 second viscosity SAE J 306)			
-15	-5	+5	+15	+25	+35	+45	°C
5	23	41	59	77	95	113	°F

The gearboxes technical data shows the amount of oil for proper use. It is recommended to replace the lubricating oil after the first 50 hours of operation, after every 1000 hours or every 6 months.

TECHNICAL DATA

Transmission ratio	Maximum torque Nm [lbf-ft]				Weight kg [lb]
	540 rpm		1000 rpm		
	C1*	C2*	C1*	C2*	
1 : 1.0	604 [445]	318 [235]	585 [431]	308 [227]	9 [19.8]
1 : 1.5	486 [358]	256 [189]	467 [344]	246 [181]	8,4 [18.5]
1 : 2.0	414 [305]	218 [161]	395 [291]	208 [153]	8 [17.6]
1 : 2.6	339 [250]	178 [131]	319 [235]	168 [124]	7,9 [17.4]
1 : 3.0	306 [226]	161 [119]	—	—	7,7 [17]
1 : 3.4	253 [187]	133 [98]	—	—	8,1 [17.9]
1 : 3.8	231 [170]	122 [89]	—	—	8,1 [17.9]

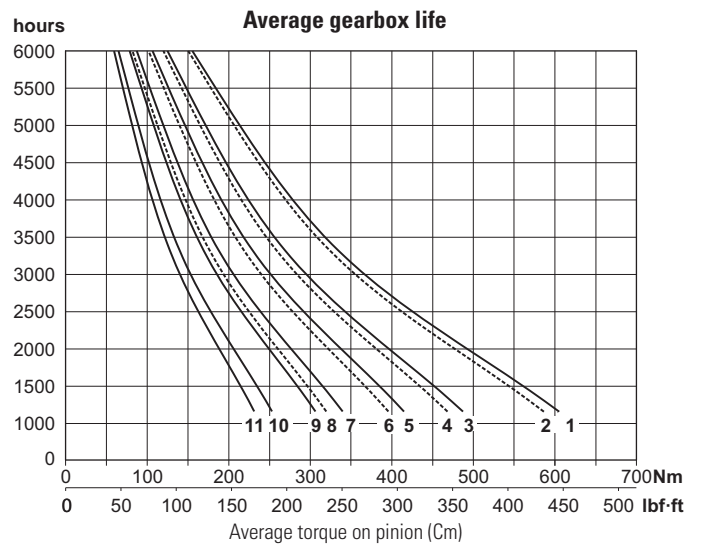

* Maximum torque on pump:
C1= maximum starting torque; C2= maximum torque for continuous duty.

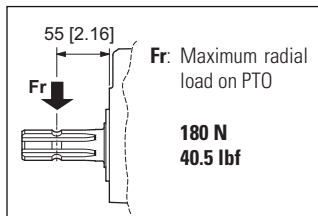

Mounting positions	Oil liters [US gallon]
1	0.34 [0.09]
2	0.80 [0.21]
3	0.52 [0.14]
4	0.75 [0.20]

Input rpm		Output (transmission ratio)						
		1 : 1.0	1 : 1.5	1 : 2.0	1 : 2.6	1 : 3.0	1 : 3.4	1 : 3.8
540	curve	1	3	5	7	9	10	11
	rpm	540	810	1080	1408	1620	1836	2057
1000	curve	2	4	6	8	—	—	—
	rpm	1000	1500	2000	2607	—	—	—

SPARE PARTS

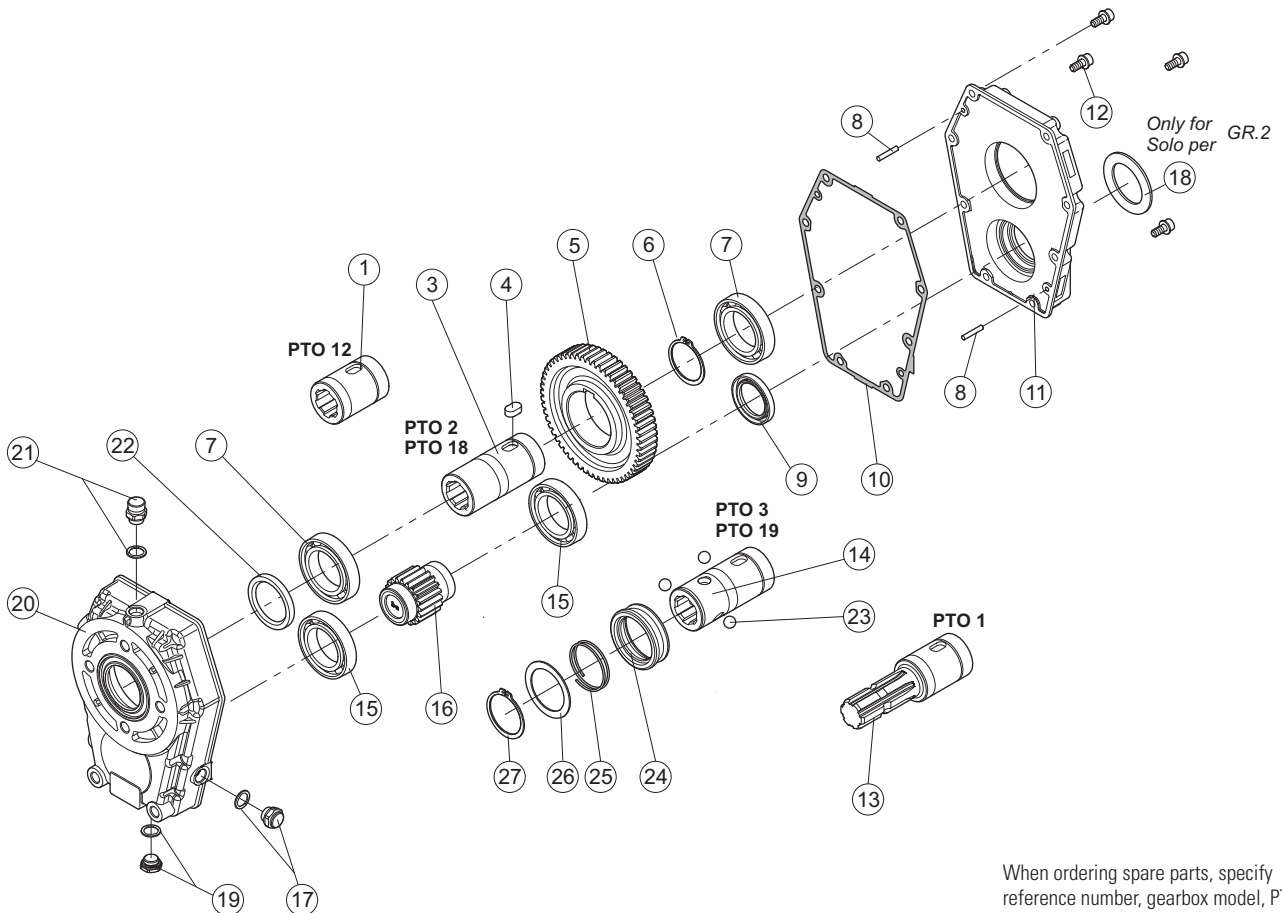

When ordering spare parts, specify reference number, gearbox model, PTO type and transmission ratio.