

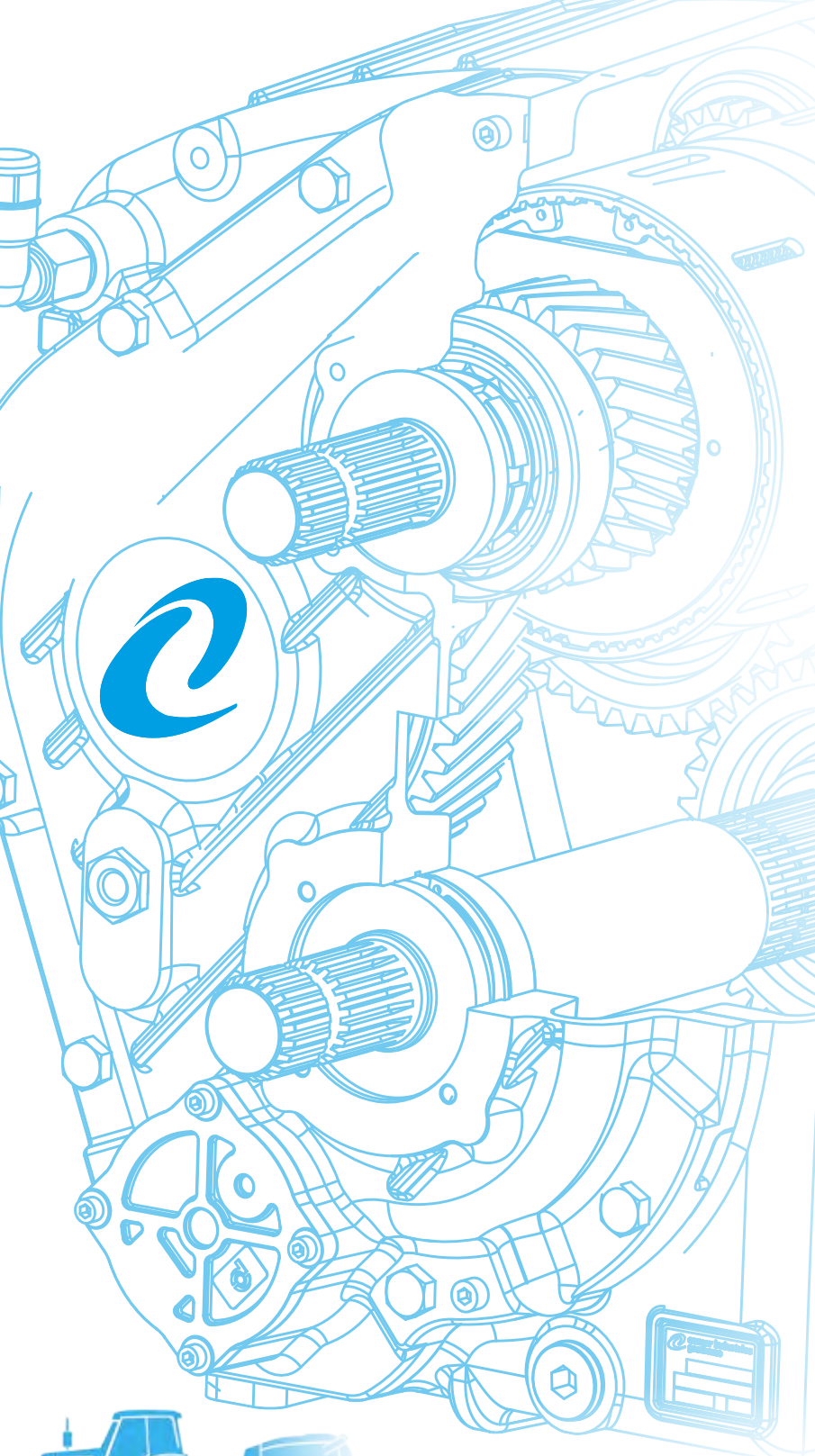

























comer industries



GEARBOXES











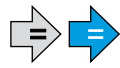
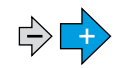
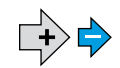



The easiest way to go far in agriculture

		Applicazioni <i>Applications</i>	p.
Profilo aziendale	<i>Company Profile</i>		4
APPLICAZIONI STANDARD STANDARD APPLICATIONS		(0.00)	
Gamma angolari applicazioni generiche	<i>Generic Application Angular Gearboxes</i>	 (0.01)	6
Gamma assi paralleli applicazioni generiche	<i>Generic Application Parallel Gearboxes</i>	 (0.02)	48
MACCHINE PER LA PREPARAZIONE DEL TERRENO MACHINERY FOR LAND PREPARATION		(1.00)	
Trinciastocchi	<i>Flail Mowers</i>	 (1.01)	64
Falciadistruggierba	<i>Rotary Mowers</i>	 (1.02)	84
Decespugliatrici	<i>Rotary Cutters</i>	 (1.03)	
Spandiletame	<i>Manure Spreaders</i>	 (1.04)	100
Decespugliatori idraulici	<i>Hydraulic Cutters</i>	 (1.05)	106
MACCHINE PER LA LAVORAZIONE DEL TERRENO MACHINERY FOR SOIL TILLAGE		(2.00)	
Zappatrici - Fresatrici	<i>Rotary Tillers</i>	 (2.01)	110
Zappatrici multiple	<i>Multiple Rotary Tillers</i>	 (2.02)	
Erpici rotanti	<i>Rotary Harrows</i>	 (2.03)	
Trivelle	<i>Post Hole Diggers</i>	 (2.04)	144
MACCHINE PER IL TRATTAMENTO DELLE COLTURE MACHINERY FOR PLANT AND CROP TREATMENT		(3.00)	
Atomizzatori	<i>Sprayers</i>	 (3.01)	150

			Applicazioni <i>Applications</i>	p.
MACCHINE PER IL TRATTAMENTO DELLE COLTURE MACHINERY FOR PLANT AND CROP TREATMENT			(3.00)	
	Spandiconcime	<i>Fertilizer Spreaders</i>	 (3.02)	160
	Pompe centrifughe per irrigazione	<i>Centrifugal Pumps for Irrigation</i>	 (3.03)	166
	Irrigatori a bobina	<i>Irrigation Reels</i>	 (3.04)	
MACCHINE PER FIENAGIONE MACHINERY FOR FORAGE AND HAY			(4.00)	
	Falciatrici rotative	<i>Cutter Bars</i>	 (4.01)	178
	Giroandanatori	<i>Rotary Rakes</i>	 (4.02)	190
	Spandifieno rotativi	<i>Rotary Tedders</i>	 (4.05)	
	Presse raccogliatrici	<i>Round Balers</i>	 (4.04)	204
MACCHINE PER LA MISCELAZIONE E DISTRIBUZIONE FORAGGIO MACHINERY FOR MIXING AND DISTRIBUTION OF FORAGE			(4.00)	
	Carri miscelatori	<i>Feed Mixer Machines</i>	 (4.06)	210
	Lancia paglia	<i>Straw Blower</i>	 (4.09)	
MACCHINE PER TESTATE DA MAIS E CEREALI MACHINERY FOR CORN HEADER AND GRAIN HEADER			(4.00)	
	Punte da mais	<i>Corn Headers</i>	 (4.06)	232
	Gruppi per testate da grano e girasoli	<i>Grain Header and Sunflower Headers</i>	 (4.10)	238
APPLICAZIONI VARIE MISCELLANEOUS APPLICATIONS			(5.00)	
	Gruppi elettrogeni	<i>P.T.O. Generators</i>	 (5.01)	244
	Seghe circolari - a nastro	<i>Circular Saws - Belt Saws</i>	 (5.02)	

			Applicazioni Applications	p.
MIETITREBBIA E TRINCIA SEMOVENTE COMBINE AND FORAGE HARVESTER			(6.00)	
Cinematismi per mietitrebbie	<i>Combine Harvester Solution</i>	 (6.01)	256	
Cinematismi per trincia semoventi	<i>Forage Harvester Driveline Solution</i>	 (6.02)	258	
Cinematismi per macchine semoventi	<i>Self-propelled Windrower Solution</i>	 (6.03)	260	
INDICE ANALITICO ANALYTICAL INDEX				262

i	Rapporto di riduzione <i>Reduction ratio</i>
	Rinvio <i>Gear unit 1:1 ratio</i>
	Moltiplicatore <i>Speed increasing unit</i>
	Riduttore <i>Speed reduction unit</i>
 OIL [l]	Quantità lubrificante <i>Oil (or grease) quantity</i>
 GREASE [kg]	
 kg	Peso <i>Weight</i>

	Alberi scanalati maschio <i>Splined male shafts</i>
	
	Albero cilindrico maschio con linguetta <i>Cylindrical male shaft with key</i>
	Albero cilindrico femmina con linguetta <i>Cylindrical female shaft with key</i>
	Albero cilindrico maschio con fori ortogonali <i>Cylindrical male shaft with cross holes</i>
	Albero scanalato femmina <i>Splined female shafts</i>
	
	Albero conico maschio <i>Conical male shaft</i>
	Albero esagonale femmina <i>Hexagonal female shaft</i>



Per configurazioni non a catalogo contattare Servizio Tecnico-Commerciale
For non-catalog configurations contact Technical-Commercial Service

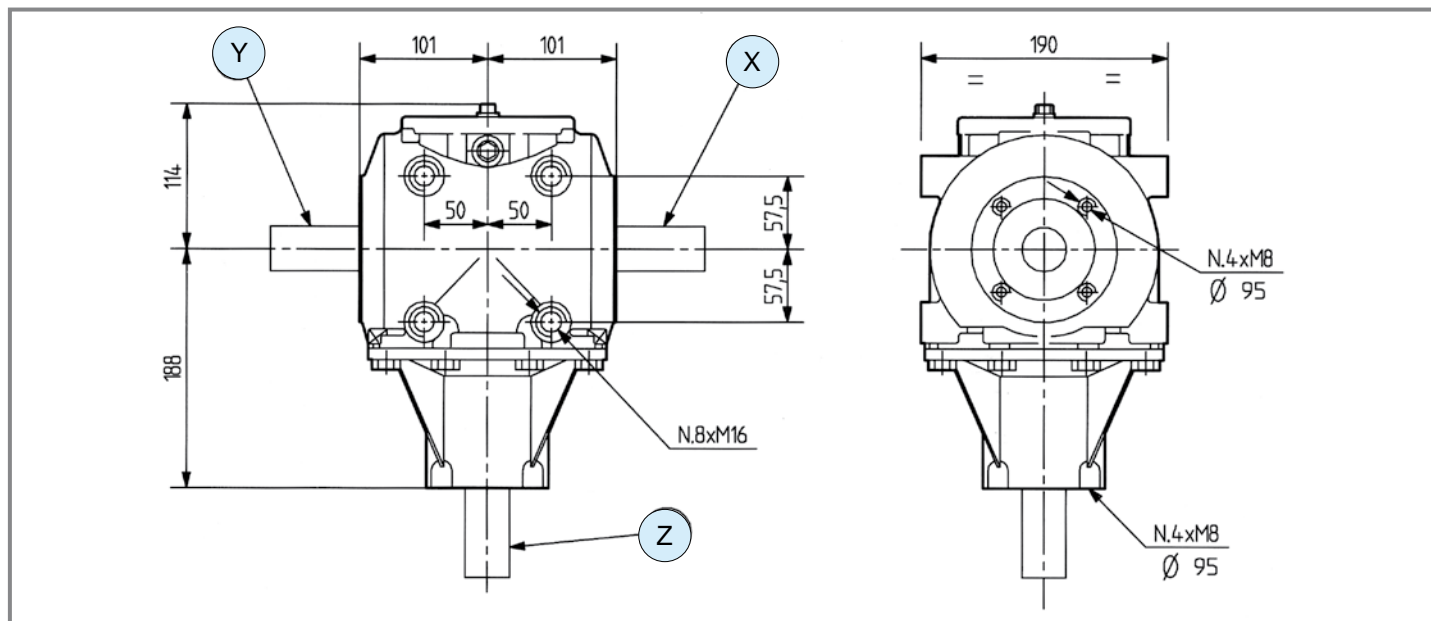

5 - Rinforzato / Reinforced

	i	N ₁ [rpm]	P ₁ [kW]	M ₂ [Nm]	Shaft type			Input	Option	Code	Mounting	
					X	Y	Z				Diagram 1	Diagram 2
M →	2.91	540	33.1	195		-		X	-	9.278.013		std
	2.91	540	33.1	195				Y	-	9.278.014		std
	2.33	540	38.3	282				X	-	9.278.011		std
	1.92	540	40.5	362		-		X	-	9.278.006		std
	1.92	540	40.5	362				X	-	9.278.008		std
	1.92	540	40.5	362		-		Z	-	9.278.007		std
- →	1.00	540	40.5	695		-		Z	-	9.278.000		std
	1.00	540	40.5	695		-		Z	-	9.278.001		std
	1.00	540	40.5	695				Z	-	9.278.002		std
	1.00	540	54.0	926				Z	5	9.278.095		std

T-278A

Code 278



(0.01)



	i	N ₁ [rpm]	P ₁ [kW]	M ₂ [Nm]	Shaft type			Input	Option	Code	Mounting	
					X	Y	Z					
R →	1.35	540	41	949				Z	-	9.278.097		std
	1.46	540	40.5	1014				Z	-	9.278.262		special
	1.60	540	36.8	1010				Z	-	9.278.005		std
	1.92	540	33.1	1090		-		Z	-	9.278.006		std
	1.92	540	33.1	1090				Z	-	9.278.008		std
	1.92	540	33.1	1090		-		Z	-	9.278.007		std
	2.33	540	25.0	999		-		Z	-	9.278.224		std
	2.33	540	25.0	999	-			Z	-	9.278.010		std
	2.91	540	21.3	1063		-		Z	-	9.278.012		std

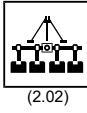

Per configurazioni non a catalogo contattare Servizio Tecnico-Commerciale
For non-catalog configurations contact Technical-Commercial Service

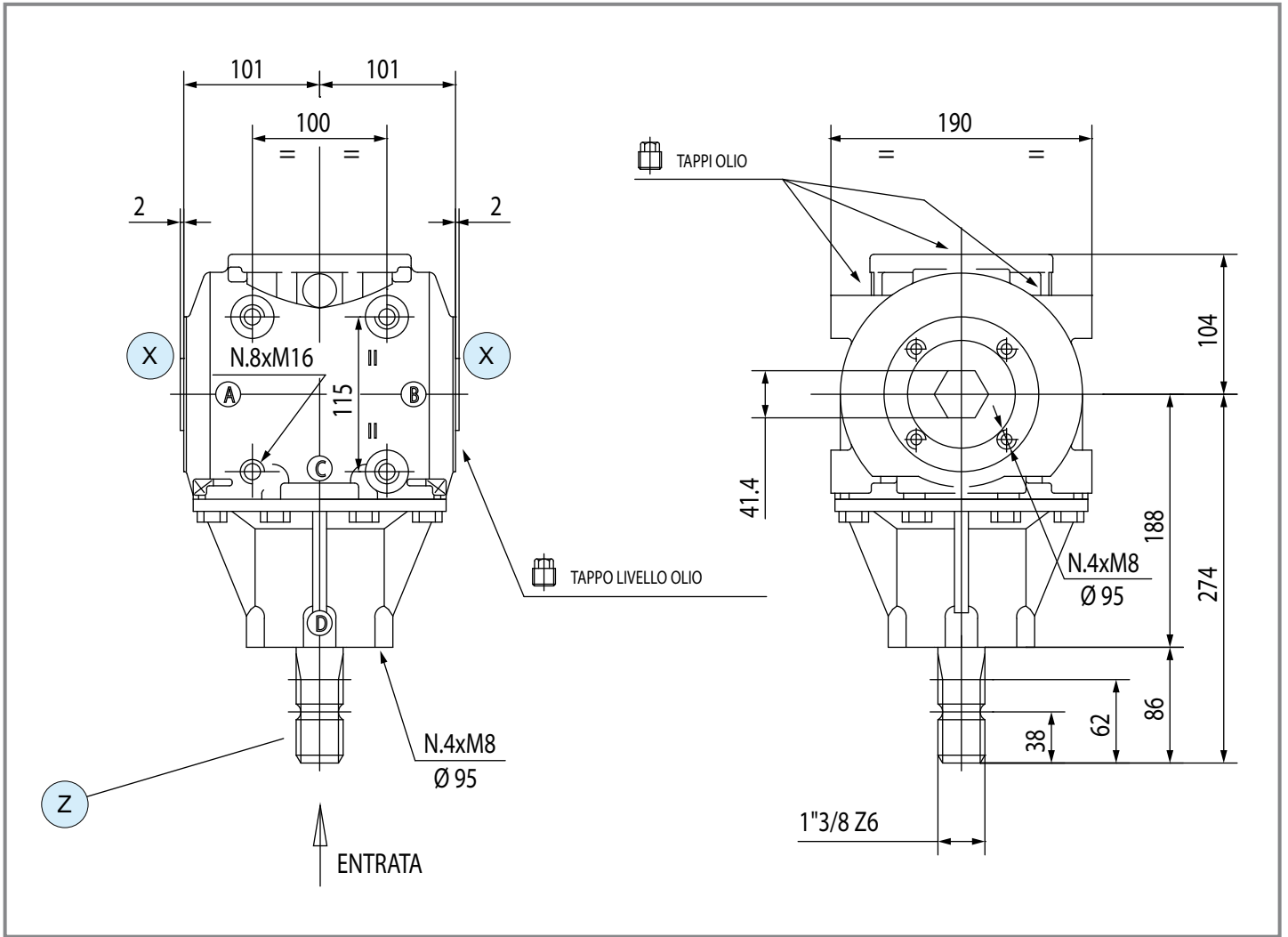

	i	N ₁ [rpm]	P ₁ [kW]	M ₂ [Nm]	Shaft type			Input	Leght	Code	Mounting	
					X	Y	Z				5	6
-	1.00	540	40.5	695		-		Z	-	9.278.524		std
R	1.60	540	36.8	1010		-		Z	-	9.278.018		std
	1.60	540	36.8	1010		-		Z	-	9.278.019		std
	1.92	540	33.1	1090		-		Z	-	9.278.020		std
	1.92	540	33.1	1090		-		Z	-	9.278.021		std

Zappatrici, fresatrici ed erpici rotanti
Rotary Tillers and Rotary Harrows

T-278D

Code 278



(4.01)



[kg]	55	[l]	1.2+1
------	----	-----	-------

Per configurazioni non a catalogo contattare Servizio Tecnico-Commerciale
For non-catalog configurations contact Technical-Commercial Service

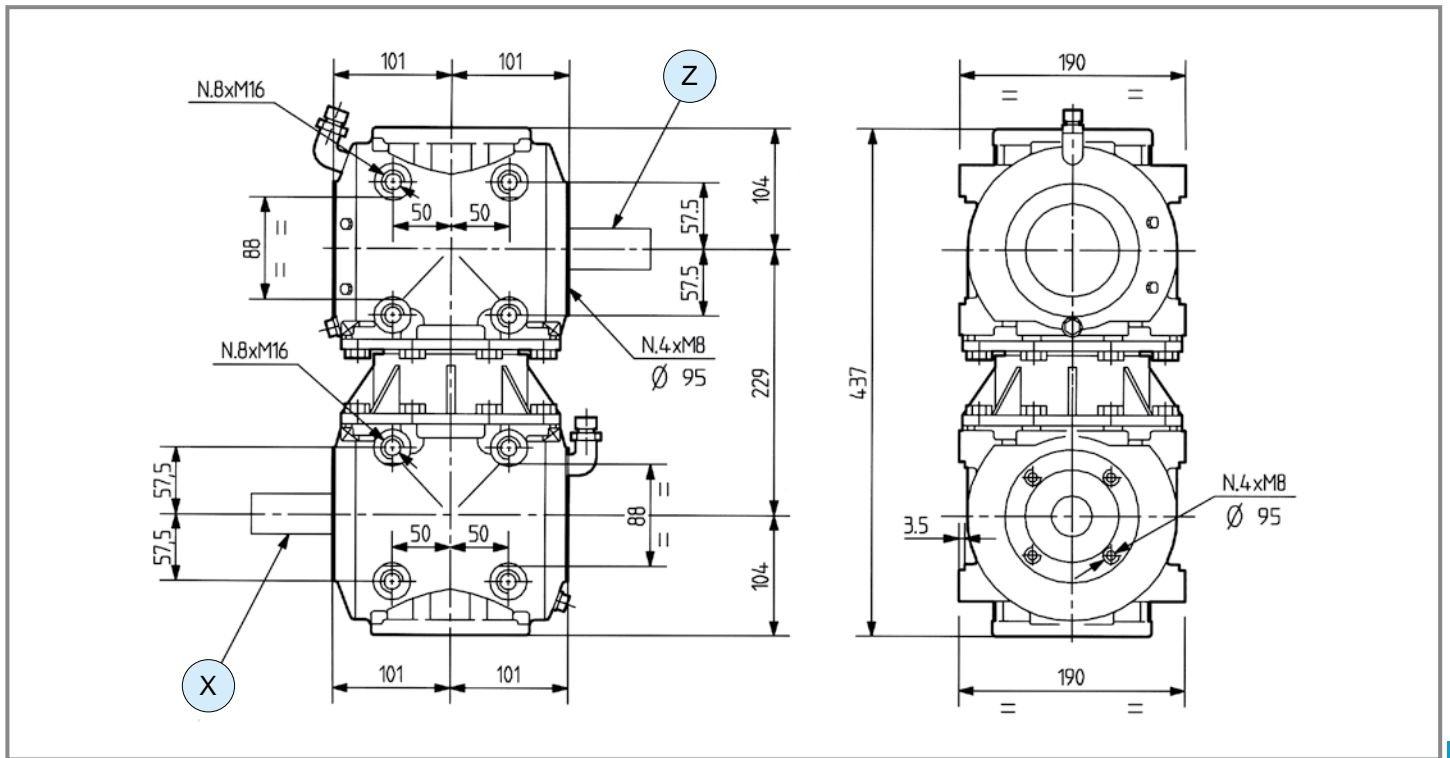

Falcatrici rotative
Cutter Bars

	i	N ₁ [rpm]	P ₁ [kW]	M ₂ [Nm]	Shaft type			Input	Option	Code	Mounting
					X	Y	Z				
	1.35	540	44.1	560		-		X	-	9.278.215	std
	1.35	540	55.0	699		-		X	-	9.278.232	std